

# Connections

SOUND • LIGHTING • STUDIO • AV • MUSIC TECHNOLOGY • THEATRE • TOURING • SHOWBUSINESS

## PHANTOM:

Revealed - how they do those staging tricks

## STING & LENNY:

Lighting & Live Sound reviewed

## Products:

DA 88 Reviewed, Sequencers & Sound Modules, All about Colour, Audio Test Gear; New from NAMM

## Contracting News section

## Music Monthly:

**NEW** section ...

Products, Reviews, Pics, People & News!

## 50 Recording Studios:

BASF Tracking Guide

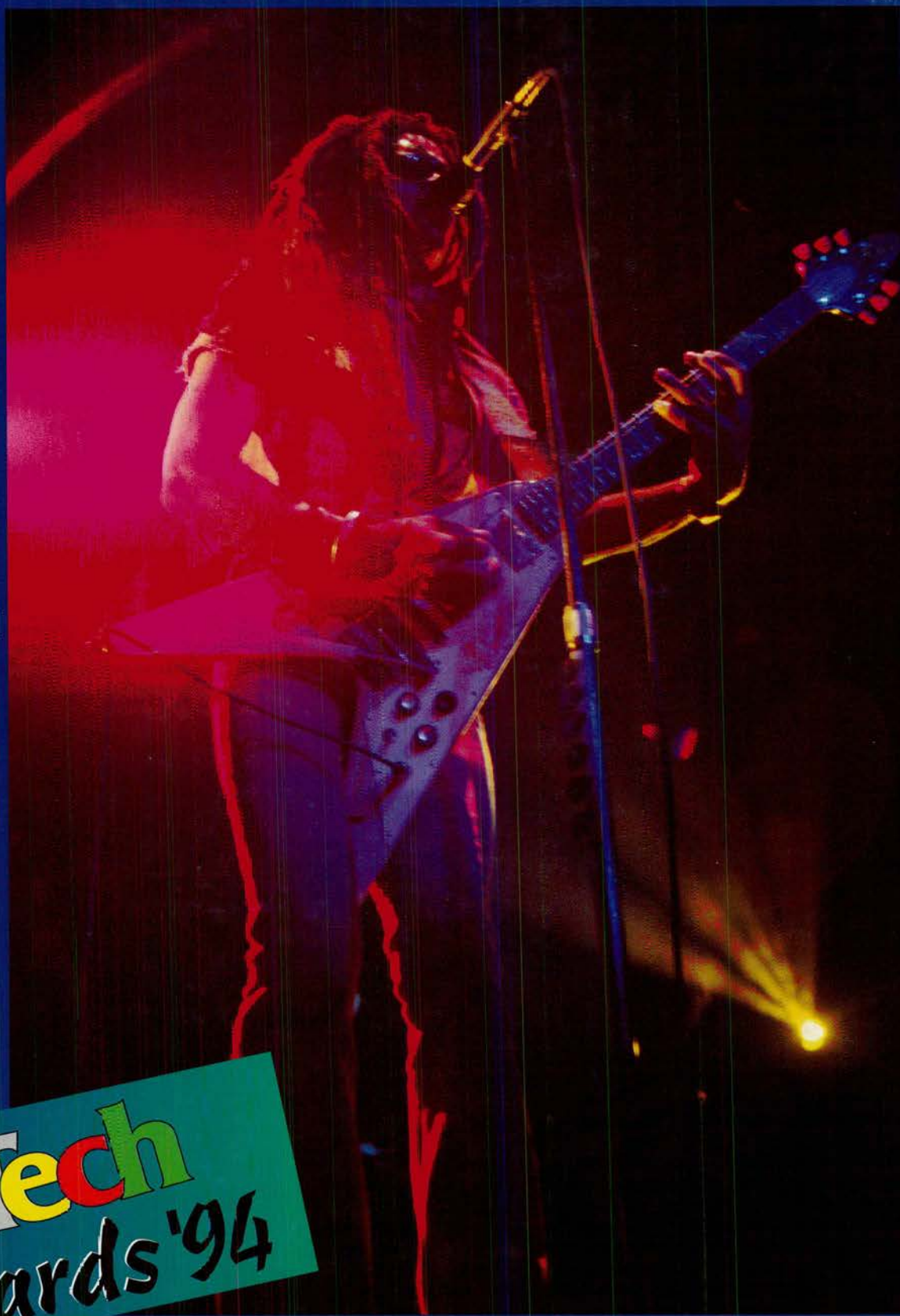

**Entech**  
Awards '94

**VOTING FORM INSIDE**

Introducing  
**SHURE SOUND**  
from a Wireless System  
**YOU CAN TRUST**

Genuine Shure Quality . . .

The new Shure EC wireless microphone systems feature the classic sound and legendary ruggedness of their Shure cabled microphone counterparts. Available in multiple configurations, the EC Wireless Series provides the singularly trouble-free dependability you expect from Shure.

Designed, engineered, and manufactured in the U.S.A. to meet worldwide standards, the EC Wireless Series outperforms competitive units costing substantially more.



**EC2/58**  
Uses the world-famous SM58 dynamic element.

**EC2/Beta 58**  
With the industry standard Beta 58 supercardioid dynamic element.

**EC2/87**  
With Shure's high performance SM87 condenser element.

**EC2/Beta 87**  
With Shure's advanced new Beta 87 supercardioid condenser element.

**SHURE**<sup>®</sup>

**EC** SERIES

**JANDS**

578 Princes Highway  
St. Peters 2044  
N. S. W.  
(02) 516-3622 • Fax: (02) 517-1045

# Fostex

# RD-8

# RD-8

# RD-8

# RD-8

# RD-8

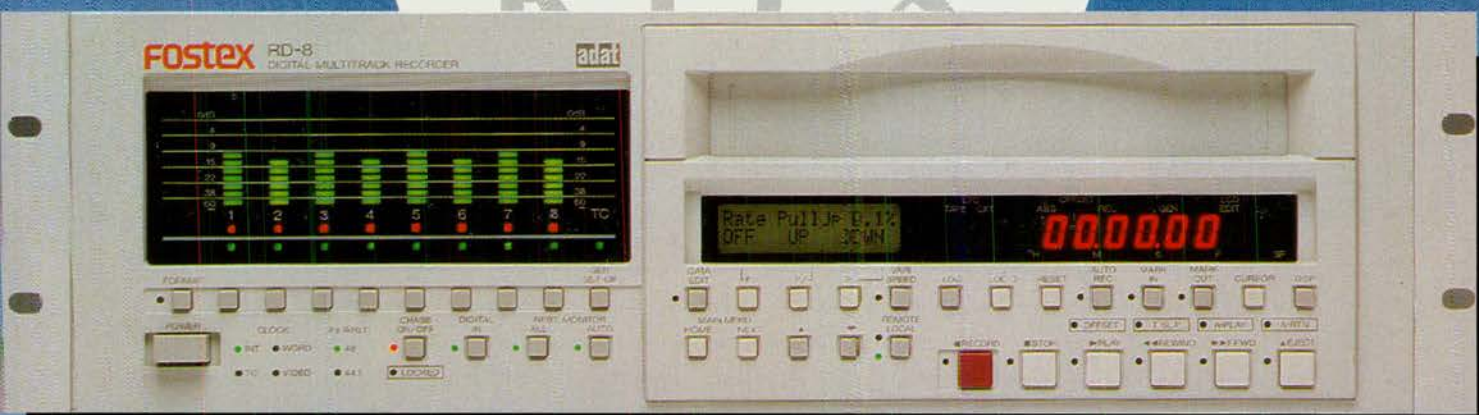

- 8 track recorder compatible with Alesis ADAT
- Up to 100 locate memory points are possible
- RS-422 port is provided as standard equipment
- Complies digital I/O: 8 channel serial (optical) ADAT format
- Allows you to set the Pre/Post Roll time 1 to 30 seconds at one second increments
- TC Generator (Int/Ext reference switchable) is installed and can be set to any start time

Distributed by: **SYNTEC INTERNATIONAL**

#### Available from:

#### NSW

Terra Murra Music 449-8487  
Harbour Music 438-4300  
Hutchins Keyboards 387-5507

#### Queensland

Music Junction 369-9033  
Buzz Music (070) 51-9666

#### Victoria

Allans Music 654-8444  
Audio OZ 696-5690  
Manny's Music 416-1564  
Soundcorp 416-1036  
Technical Workshops 888-2333

#### Adelaide

B.S.S. Light & Sound  
Innovations 352-8688  
Adelaide Rock Shop 212-7933

#### Perth

The Music Man 451-8944  
Sound Engineering 354-1778  
Collins Music (097) 21-2C10

Write in 108 on Reader Service Card for more info



# DN3600

PROGRAMMABLE  
GRAPHIC EQUALISER



## Instant control, easy access.



The new DN3600 provides a perfect union of Klark Teknik precision with breathtakingly straightforward control.

The largest LCD display available in a 2U rack space shows either a single 1/3 octave 'graphic' display, a combined curve, or both channels. Also shown are high and low pass filters and two notch filters per channel.

The unique Alphanumeric memory

display allows fast save/recall; four 'soft keys' access display sub-menu options and there's full Password Protection.

Dedicated backlit switches include each equaliser centre frequency, while rotary controls for band and level provide extra instant access. You may link channels for accurate stereo tracking and 'Q' can be switched between DN360 and DN27 curves. There's Auto

Gain, maintaining constant level whatever the curve; Pro MIDI; 66 memory patches and a DN60 interface.

Audio quality is stunning, too, with unrivalled dynamic range and headroom. We've even sealed the front panel behind a tough membrane for years of trouble-free use.

The DN3600 from Klark Teknik. For instant control, nothing touches it.



# KLARK TEKNIK

a MARK IV company

The first name with sound system designers

A.R. Audio Engineering  
NSW (02) 299 3695

Audio Oz  
VIC (03) 696 5690

The P.A. People  
QLD (07) 857 6855

The P.A. People  
NSW (02) 642 5344

Troy Balance Corp.  
VIC (03) 699 3844

Osmond Electronics  
SA (08) 410 1111

Write in Reader Service number: 134

# Sting

Lighting & Sound reviewed, a classic case of 'let the music do the talking'. You don't leave a show humming the lighting - or do you?  
**Page 33**



# Editors note

The phones started ringing in early January as the industry experienced a recovery in confidence. Trade is well up on last year, reports from NAMM say the Music (MI) sector is bullish, locally the sound & lighting hire firms are booked solid, and contractors say tenders and projects are rolling. It's still a bumpy road in professional studio land, but the high start-up rate for home/project studios is showing no sign of falloff. But let's not forget the recession.

**THIS ISSUE** we hope you'll find better organised - from now Contracting News will appear each 2nd issue, alternate with Multimedia World. We've sectioned Lighting too, and the Studio section works!

**M.I. MONTH** is a new section that better presents to our musical readership. We know you're out there, because we see it on Reader Service Cards and Subscription Renewals. As always, we are Open To Suggestions - and stories.

The **ENTECH AWARDS** are here, the voting form in the middle of this issue is your chance to cast a credible vote for your favourite equipment, and industry peers. **ENTECH** is a lot more than a trade show. Vote now, it counts.



# NAMM

Our world-weary tradeshow reviewer wrote 'NAMM BIMBO'S' on the back of this picture, before we quickly shot him for being (a) gender specific, and (b) wrong. Turkey! We KNOW where the REAL bimbo's were at NAMM.... ANYWAY, we report on **WHATS NEW**, in Pro Audio (**Page 8**) and Music Gear, in our new MI Monthly section, starting: **Page 75**.

## REGULAR

Showbiz news 7

Events 10

Profile: Tony Mott 11

Aux 2 column 16

Phil tripp 16

Letters 18

Hire Biz Buz 24

BASF Tracking Guide 47

Acoustician 68

Duncan Fry 69

Social Page 70

The PA Page 86

# Phantom

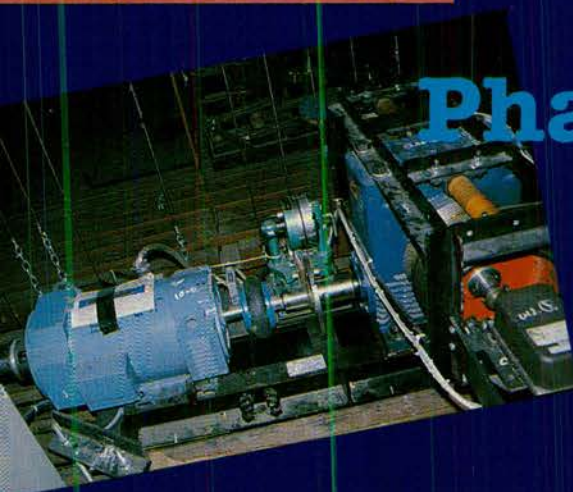

Truly at the leading edge of theatre technology, is Phantom Of The Opera. We detail the mechanicals and electricals that create the trickery behind the show. **Page 28**

# MI Month

## NEW SECTION

Starts Page 75

Studios Starts Page 38

Contracting News

Starts Page 62

Lighting Starts Page 75



Analogue Lenny - he of our cover - doin' it right for valve manufacturers, (above). Foldback amps at Sting (left). Colour photography this issue by Cat Forcer.

# CHALLENGE THE GLADIATORS

## THE GLADIATOR RANGE:

- **MINI STARBURST 250W-200MSD**
- **SAGA 250W-200MSD (AS PICTURED)**
- **SCENE SETTERS**  
**(COLOUR CHANGER 250W-200MSD)**
- **MASTERSTROKE CONTROLLERS**



## ABSTRACT™ DESIGN TO LIGHT

**ABSTRACT™ DISTRIBUTION (075) 290 688**

SEE YOUR NEAREST ABSTRACT™ STOCKIST FOR THE FULL RANGE OF ABSTRACT™ PRODUCTS.

### **NSW & ACT**

**Black Express Light & Sound**  
Phone: (02) 559-4363 Fax: (02) 558-4923  
**Lightmoves Technology Pty Ltd**  
Phone: (02) 560-0000 Fax: (02) 568-2333

### **VIC**

**Australian Disco Services**  
Phone: (03) 484-1178 Fax: (03) 484-2624  
**CPN 2 Lighting & Sound**  
Phone: (03) 380-8004 Fax: (03) 380-1667

### **QLD**

**Creative Lighting & Sound Systems**  
Phone: (07) 252-5686 Fax: (07) 252-4778  
**Entertainment Lighting Supplies**  
Phone: (075) 93-5105 Fax: (075) 93-5161  
**Mick James Electronics**  
Phone: (075) 72-0133 Fax: (075) 72-4478

### **NT**

**Mighty Music**  
Phone: (089) 854-224 Fax: (089) 854-224

### **WA**

**Audio Source**  
Phone: (09) 354-3185 Fax: (09) 354-2354  
**Kosmic Sound & Lighting**  
Phone: (09) 242-3844 Fax: (09) 444-1144

### **SA**

**Osmond Electronics**  
Phone: (08) 410-1111 Fax: (08) 410-3322

### **NEW ZEALAND**

**Lighting Supply Company**  
Ph: 64 9 838-9217, Fax: 64 9 834-4326



# SHOWBIZ

## NEWS & UPDATE



Audio position at Lenny Kravitz show in Sydney, the tour went out just days after A.T.S. ceased to be. Jands did the lighting while Audio & Recording supplied a Meyer PA system. With A.T.S. out of the way, firms like Audio & Recording are more isolated, with one less 'friendly' lighting firm on the market.

## Jands Buy Arena Technical Services

This official release details what Jands plan next after buying all ATS's equipment....

Jands Production Services have entered into an agreement with Arena Technical Services (ATS), to purchase their complete inventory of rental equipment. ATS has now ceased to rent sound lighting and video equipment although Arena Management is still actively involved in many aspects of the entertainment industry, most notably the management of the Sydney Entertainment Centre and the Capitol Theatre.

Jands have been enjoying one of their busiest summers for many

### School Of Audio Education

The headline to a story about the Melbourne based Recording Industry Training Centre on Page 29 of the February 1994 refers to 'Victorian SAE' in error. The editor apologises to the School Of Audio Education for his dumb error.

years and have been working long hours putting equipment and crews out with just about everyone to tour this season. Recent and upcoming tours include; John Farnham, Crowded House, INXS, Sting, Lenny Kravitz, Bryan Adams, Johnny Cash/Kris Kristofferson, Michael Bolton Peter Gabriel, Jethro Tull, and Depeche Mode. Meanwhile Jands have also been busy in New Zealand where a new theatrical production of Jesus Christ Superstar has just opened and in Singapore where they have opened an office to service the Asian market. The Singapore office has put out sound systems for the Asian legs of tours by Bryan Adams, Sting, The Scorpions, INXS and is currently preparing for Bob Dylan. Industrials have also been keeping the company busy; Jands constructed the Toyota and Lexus motor show

stands and are about to start construction at the Melbourne motor show. For the David Jones Advance Winter fashion parades Jands put out sound and Varilite systems for dates in the Sydney, Melbourne, Brisbane and Adelaide stores.

The decision to purchase the ATS equipment was based on Jands need to rapidly increase its equipment level to better service existing clients and to allow the company to expand into new areas, particularly the corporate market.

The company is establishing a new division to focus on the needs of event producers and other corporate show specialists and will also be expanding its driveway rental business to provide sound, lighting rigging and AV equipment for casual hire.

*\*The buyout came from the blue, with little notice say ex ATS staff.*

### Connections Magazine

Published by Connections Publishing Pty Ltd. ACN 058443182.

#### All Mail:

P.O. Box 439, Epping  
NSW 2121 Australia

#### Phones:

Advertising: (02) 876-3530.

Editorial: (02) 876-2612.

Faxes: (02) 876-5715.

International prefix: (+61)

Editor: Julius Grafton.

Features writer: Catriona Forcer

Studio Editor: Caroline Grafton

Audio Technical: Greg Simmons

Showbiz News: The Weazel

#### Contributing writers:

Duncan Fry, Howard Jones,

Paul Bryant, 'The Idiot',

Glenn Leembruggen, Bruce

Waite & Dave Macken, Phil

Tripp, Michael Orland, Paul

Matthews, Ray Bond (Singapore)

Advertising: Caroline Grafton.

Administration: Elaine Auld

Graphic Art & Layout: Josh Luo,

Catriona Forcer, Julius Grafton.

D.T.P. System: Apple Mac, PM5

D.T.P. film output: Artscan

Film imposition: Omicron

Publishers: Caroline Grafton &

Julius Grafton.

#### Newsagents Distribution:

N.D.D. - call (02) 353-0512

#### Music Store, Direct Outlet

Distribution: 50% discount!

Call us direct: (02) 876-3530

#### Subscriptions: AUSTRALIA:

\$29.50, NZ: \$55, Asia \$60,

Thailand/Korea/Japan/China \$70,

USA \$90, Europe/UK \$100. Int.

airmail, all AUD \$, all 12 mths.

**Submissions:** We WELCOME well written articles and stories for consideration. Send hard copy, pref. with PC or Mac word processing disk file. Photograph prints, B&W or colour, & tranny's (not neg's) also considered. Send stamped self addressed envelope if return of material is required.

All contents © Connections Publishing Pty Ltd, 1994. Nothing herein to be reproduced in any way or transmitted by any means without the express written consent of the Publisher. No Warranty is extended in respect to any information herein. Opinions expressed in Connections are by no means those of the Publisher. Materials herein reproduced in good faith. Corrections made wherever material errors occur. It is a condition of purchase that the Publisher does not assume liability or responsibility for loss or damage that may result from any inaccuracy or omission in this publication.

100% Produced & Printed in Australia.

# NAMM SETS PRODUCT PACE

Ray Bond reports on the shake, rattle and roll at the huge tradeshow in LA

Although held only 48 hours after the big LA earthquake, the 1994 Winter NAMM show was HUGE.

New for the '94 show was a section dedicated to Pro-Audio, another for Disco Equipment, and a section just for lighting - a trend started by the Frankfurt Music Messe to encompass all aspects of the trade, 'covering all the bases'.

**NEW:** Amplifiers, and Peavey's CS-X is a heavily updated remake of their near classic CS range, to try to take the title of world largest Pro Amp maker, held by QSC who build 80,000 pieces yearly. From Yamaha comes the good but expensive H series, a 2 rack space range with a 15 pin comm port for PC control (Media link?) to allow monitoring of input signals, o/p levels, clipping, etc.

The Lone Wolf MediaLink band wagon continues with the new Carver PM Series fully MediaLink compatible, other MediaLink licensees are TOA, Yamaha, Crown, JBL, UREI, Altec, EV and QSC. Who will be the first Australian licensee?

New Crest amplifier products were detailed in the last Connections, I still find it hard to believe or accept the huge power being quoted for new products is real or necessary. What happened to efficient speaker designs?

**MIXING CONSOLES:** Lots, no fewer than 6 new from Soundcraft, I'd hate to see their R & D bill! On the studio front they showed their new DC2000 with digital control and moving faders automation, all for under \$25K US and the Spirit Studio LC that is headed for home and project studios. Each channel has channel and monitor paths plus a unique Fader Flip facility to switch monitor and channel's signals with re-patching. This InLine design with 8 bus grouping appears to be ideal for the current crop of 8 channel digital recorders. Soundcraft also released 4 new Live sound consoles to stretch the range to 17 with no fewer than 26 models. Included was the Vienna II, SM16 stage monitor console, Folio 4 and Folio Si. (Is choice a good thing? -Ed)

Soundcraft are part of Harman and distributed in the USA by JBL, whose Northridge warehouse suffered when the sprinklers soaked hundreds of consoles in the quake. Look out for cheap US origin Soundcraft's!

Another part of Harman going great is Allen & Heath who Harman rescued from death for a reputed \$1 (plus debts) a few years back. Their new models continue to be innovative and priced right, this NAMM saw the release of the GL2, a rack mountable version of



What can you say about this?

the GL3 aimed directly at the successful if overhyped Mackie 1604.

Mackie's big release for the show was their low cost Automation system called 'AUTOMATION' which can be used with their newly released 8-bus range (16-8, 24-8 and 32-8). It features a separate Fader bus and requires no external PC, for under 3K US - I guess about \$6000AUS. The Australian importer could not contain himself, perhaps it was beer ....

Alesis finally had a working model of their much talked about X2 24 channel in-line 8 Group Studio Mixer complete with 'Dynamic Mute Automation'. It may however be a little late as competition in this market is absolutely fierce with technology being outdated before it's released. Important for Alesis will be price, price, and price - plus Alesis' superb marketing.

Something new and certainly different was the Tactile Technology M4000 automated mixer, with



Tactile Technology - could be one to watch

unique features including a single EQ section that is allocated each channel as requires plus automated faders, mutes, input gain, phase, inserts in/out and bus routing. Fully MIDI controllable it can be expanded to 120 input channels in dual in-line configuration.

This in turn offers up to an incredible 240 signals available for mixdown.

## SPEAKER SYSTEMS:

Yamaha showed their WaveForce series of SR speakers that use a Spherical Horn to eliminate discontinuities, reflections and narrowing created by conventional horns. No mention of the effect of this horn on directivity, so important in today's world of high level sound reinforcement.

E.V. were out in force with new System 200, made from Polypropylene structural foam. The full range cabinet is the Sx200, a 12" 2 way with moulded CD horn and less than 18kg with inbuilt

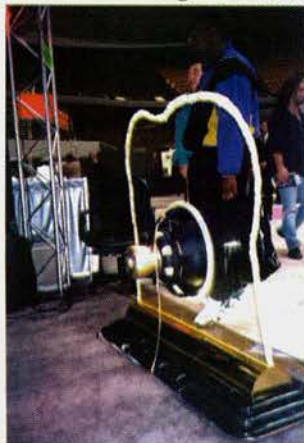

Aurasond - a new concept

flying points and stand mount. The 12" sub woofer, called Sb120a comes with inbuilt 400w digital

## WHO? WHERE? WHEN?

The publishers of the Australasian Music Industry Directory utilise Connections to provide updates to entries in the previously published January '94 edition and also to track industry movements of executives, key personnel & contact changes. This is the place to be!

Please forward changes or updates to Alison Bruniges by fax on (02) 211 5938 or by mail at 3 Rose St., Chippendale 2008.

To get the most recent edition of the directory, it can be picked up at that address for \$10 at the door or \$15 prepaid by mail order.

Call (02) 212-6677 for details about being listed in the July '94 edition (listings close April 15).

Tim Delaney has been appointed Managing Director of Phonogram, while South Australian State Manager of Polygram is now Sue Hill. Queensland State Sales Manager for Polygram is now Steve Widdicombe. The following changes have also occurred at Phonogram: Roland McAdam has been given the position of Director of National Promotions and Artist Development, Deborah Banks has been appointed National Promotions Manager, while Petra Summerhays has become NSW Promotions Manager.

David Loiterton, Asian director for MMA Music and MMA Management based in Hong Kong, has left the company to head up BMG Music Publishing Asia Pacific.

Suzie Biro, dance music co-ordinator of Festival has left the company.

The Australian Broadcasting Authority (ABA) has closed its offices in Queensland and Melbourne.

Midnight Oil manager Gary Morris has moved back to Sydney from his year in New York and can be reached via The Office.

Ingrid Berg Publicity have moved to: 2 Vernon Street, Petersham, NSW 2049. Phone: (02) 564 3833, Fax: (02) 564 1646.



Soundcraft DC2000

compression drivers, 2 x 6.5" mid drivers and a single 12" woofer that promises 130dB. The CE-3MH mid high cabinet utilises no less than 6 x 1" compression drivers and 6 x 6.5" mid Drivers for 136dB Maximum SPL. It is used in conjunction with the CE-3LOW, a 4 x 12" sub using RCF woofers that is said to max out at 136dB. But...

switching (power supply -Ed) amp, flying points and weighs less than 16kg. System control comes from the Xp200 processor, a worthy replacement for the long serving S-200's that most Hire Companies in Australia still rent out. EV also had their answer to JBL's SR Series speakers with the T-Series, full range cabinets with biamping.

Our Editor's old friends **Rerkus Heinz** (ask me one day! -Ed) had the Total System Concept, the CE-3 full range cabinet has 2 x 1"

**Professional Audio Systems** of California were there for the 15th year with new TOC products including a tiny 2 way 15" CoAxial called the FT-1 (full range trapezoidal) as an addition to the System 1 range.

New was the patented technology of **Aurasound** who use a radically-oriented magnetic circuit that offers a flux return path that is closed internally for improved linearity and efficiency. This aerospace technology company uses Neodymium magnetic material for

its range of woofers together with its patented shape. If half of what they say is true we could be in for a major change in Woofer design, the first real one in many years. (This firm are represented here by Peter Freedman, who has big display plans for the ENTECH '94 tradeshow later this year. -Ed)

As usual there were more Speaker Companies, most just Box Builders, than you could poke a stick at, including unfamiliar names like Melhart. (Retro designs that make the 4560 look new -Ed)

**BITS:** The US Audio industry is coming swiftly out of the recession and this show was indicative that the contracting industry is growing there, while MI seems healthy as ever.

Lone Wolf's Media Link technology is growing partially because they are not linked to any audio firm. The industry needs the technology. •

□ **MORE NAMM PRODUCTS in MI MONTHLY section, Page 75**

## BUYERS GUIDES

Connections Buyers Guides bring you the latest, up to date products with prices EVERY issue! Now a **whole year** of BUYERS GUIDES ensures you get **more value from every issue!**

**February:** Wireless Mics, Studio Monitors, Scrollers, Colour changers, PC Spots.

**March:** Sequencers, Sound Modules, Test Gear, Flood Lights, Colour Medium.

**April:** EQ's, Crossovers, Limiters, Signal Processors, Backline amps, Rigging, Trussing, Flying Gear.

**May:** Effectors, Reverbs, Synths, Keyboards, Effects Lighting

**June/July:** Live Mixing Consoles, Instrument Preamps and processors, Profile Spotlights

**August:** Studio Mixing Consoles, MIDI devices, Moving Lights.

**September:** Microphones, DAW, Lighting Control

**Oct:** Amplifiers, Samplers, Dimmers

**November:** PA speakers, boxes & components, Fresnel spots

**December/January:** Recorders, Powered Mixers, Follow Spots, Fog Machines, Studio Luminaires.

**Distributors:** DEADLINE is the 15th of the month before publication. call **Caroline Grafton, (02)876-3530.**

**Musician's Union Federal Secretary John McAuliffe and Media Entertainment & Arts Alliance Federal Secretary Anne Britton** have been added to the Music Industry Advisory Council.

**Napoleon's Hotel** in the city has ceased to exist as a music venue. **The Rose Shamrock & Thistle (Three Weeds)** in Sydney has gone up for sale.

**Juice Magazine's Production Manager** is now **Melanie Black.**

**Journalist Gerard Knapp** has left **Encore Magazine** to pursue a career with an exhibitions company.

**Vera Rizzo** has left **Mushroom Records** and her position as **Publicity co-ordinator**, a position that is made redundant.

**Christie Eliezer**, former editor of the late **Juke** magazine, is now writing new music business for **Beat** magazine. If faxing **Stuart Coupe**, with news about the music industry, you should also include **Christie Eliezer**, who may be writing for overseas publications as well in the near future. **Beat** magazine's fax number is: (03) 428 3611.

**Catherine Swan** has been appointed to position of **Michael Coppel's** assistant, taking over the position after the departure of **Libby Wilson** last year.

**Ed St John** has left **Channel 10's Take 40 TV** to be replaced by producers; **Simon Fenner**, **Greg Pertherik** and **Ed Nimmervol.**

**Duncan Campbell** has been appointed **Triple M's National Programming Director**, replacing **Charlie Fox.**

**Lorraine Harvey** has left her position as **Promotions/Advertising Manager** for **Rolling Stone** and is selling space in the **Sports Directory** at **Immedia! Public Relations.**

**AUSMUSIC** have opened a centre in WA, with **Eric Erickson** appointed as **State Manager.** **AUSMUSIC (WA)** can be contacted at: **123 Claisebrook Road, Perth, 6000. Phone: (09) 227 1469, 227 7962; Fax: (09) 2277897.**

(Continues over)

## SOUND EDUCATION COURSES

ADVANCED CERTIFICATE - DIPLOMA - PRODUCER  
Full Time - Part Time - Day or evening courses



The ONLY internationally accredited course  
18 colleges worldwide

SAE is the largest audio training college established in 1977.  
Individual studio time - Record your own music - Organised theoretical lectures - Access to all our studios worldwide!



Call for NEW colour brochure and studio tour :

SYDNEY	02 - 211 3711
VELBOURNE	03 - 534 4403
BRISBANE	07 - 369 8108
PERTH	09 - 325 4533
ADELAIDE	08 - 376 0991

LONDON - PARIS - BERLIN - MUNICH - AMSTERDAM - SINGAPORE - VIENNA

# Events

AES Amsterdam, Feb 26 - Mar 1st  
 SATIS, Paris March 6 - 10  
 MUSIK MESSE Frankfurt March 16 - 20  
 SIB-RIMINI, Italy, March 27 - 30  
 NAB, Las Vegas, March 21 - 24  
 ELENEX, Thailand, March 24 - 27  
 NSCA, Las Vegas, 6 - 8th April  
 USITT, Nashville USA, 13 - 17 April  
 ISBM Italy 22- 25 April  
**MULTICOMM SYDNEY 3-5 May**  
 EXPOMUSICA Spain 10 - 13 May  
 Pro Audio, Light & Music, Beijing May 7-11  
 BROADCAST MADRID '94 11-15th May  
 BROADCAST ASIA, Singapore 1st - 4th June  
 INFOCOMM Anaheim 9th - 11th June  
 RADIO MONTREUX Switzerland 9th - 11th June  
 World Lighting Fair, Tokyo, 16 - 18 June  
 APRS London 22nd - 24th June  
**SMPTE '94, SYDNEY July 5 - 8**  
 Pro Audio & Light Asia, Singapore July 6 - 8  
 I.A.A.M. Minneapolis July 30 - August 1  
 PLASA, London, Sept 11-14  
**ENTECH '94, SYDNEY 6 - 8 October**  
 AES 97th, San Francisco Nov 10 - 13  
 LDI Reno USA Nov 18 - 20

Your **EVENT** here: FAX the details to us by the 15th of the month for inclusion. Plan ahead, be PR SMART. No cost to you....

## WHAT'S HAPPENING ....

- Still no Press release, but it seems **Peter Blackmore** will run Multicomm '94 in Sydney, May 3-5. A tradeshow and seminar together, the advertising we have sighted gives you the option of one day at \$95 or three at \$225.
- ENTECH '94 organisers confirm entry is free for trade, without pre-registration. Workshop sessions will cost a nominal \$10 - \$15 each.
- Now the Australian Music Association plan a Melbourne Music Show this year, not Brisbane.

### TASCAM/AVD DA-88 demonstrations:

At: Soundfirm, Lindfield, Sydney, **March 11 and 12th**, 11am, 2pm and 4pm. Call (02) 716-0211

### NETAA SEMINAR

**Voice Reinforcement.** Intro to voice reinforcement techniques, by Michael Summons.

**Tue 15th March, 1994.** Bookings: (02) 697-4860.

**NSW AES Section Meetings:** (Call (02) 948-4577)

**Tuesday April 12th, Tuesday May 10 (AGM)**

Australian Film, Television and Radio School will hold an **Audio Education Conference** on **July 4th**, to debate issues and problems faced by (*Caused by?-Ed*) audio educators. Call Steve Murphy on (02) 805-6582.

Vivki Caulfield has resigned as General Manager of the West Australian Music Industry Association. (W.A.M.)

Brian Evans has been appointed as Secretary of the Musicians' Union of Australia, Sydney Branch, following the resignation of Chris Harrison.

David Robinson has been appointed to the position of Head of Marketing at SBS, responsible for marketing, publicity, promotion and sponsorship.

BMG's Ken Outch is looking after National Promotions as well as Sales, following David Hunt's departure.

New location for AWA Distribution (NSW): Unit 1, 175 James Ruse Drive, Rosehill, call (02) 898-7666. Fax (02) 898-1135.

LSC Electronics now at 7 University Place, Clayton VIC. Call (03) 561-5255. fax (03) 561-5277.

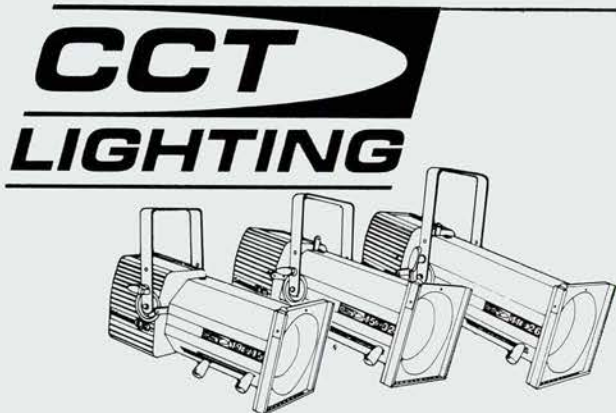

## AVAILABLE AGAIN IN AUSTRALIA THROUGH YOUR ROSCO STOCKIST

The fine range of CCT Lighting including the popular 650 watt Minuette and the upgraded 1000w/1200w Silhouette range with increased light output are worth taking a look at. New features include condenser optics, secondary Turbo reflectors, new high temperature iris, and all can be retrofitted to your existing CCT lights. Check out the new 28>58mm profile - the widest beam with hard to believe gobo projection definition and incredibly straight shutter cutting edges. What are you waiting for!

**accessories, spare parts and upgrade kits are available through Rosco dealers**

FOR FURTHER INFORMATION CONTACT  
 ROSCO AUSTRALIA PTY LTD  
 P.O. BOX 873, ARTARMON, NSW 2064.  
 PH: (02) 906 6262 FAX: (02) 906 3430

Write in Reader Service number: 140

THE FOG MACHINE THAT DOES IT ALL IN THEATRE AND LIVE ENTERTAINMENT. ....

## THE OMEGA-XT FROM ROSCO

- \* 40% greater output than Rosco's own Model 1500
- \* Supplied with Super Remote Control as standard to regulate on times and off times.
- \* Interface accessories to operate from lighting board include 0-10 volt, DMX and MIDI.
- \* Allows the use of compressed air for special effects including haze and for cleaning.
- \* Continuous fog output

## AVAILABLE NOW FROM YOUR ROSCO DEALER

FOR FURTHER INFORMATION CONTACT  
 ROSCO AUSTRALIA PTY LTD  
 P.O. BOX 873, ARTARMON, NSW 2064.  
 PH: (02) 906 6262 FAX: (02) 906 3430

Write in Reader Service number: 139

## TONY MOTT

Photographer to the stars interviewed by Catriona Forcer

Photographer Tony Mott is a familiar face at concerts in Sydney - he's the one with the Rod Stewart haircut. Originally from England, Tony first came to Australia in 1974 whilst in the merchant navy. After visiting 110 countries in a couple of years, Tony decided Australia was the place to settle. His general interest in photography and a passion for rock'n'roll, led him towards combining the two into a career.

"Really it was a hobby that just grew and grew," said Tony. "In the late seventies there were less restrictions on photographers. Deborah Harry was the one who bought in the 'three songs only' restriction because she wore so much heavy mascara after three songs it would run really badly and she hated that. That was a legitimate reason but other people thought if she could get away with it then so could they and it became a power thing."

"I toured with Iggy Pop last year on the Big Day Out and he was strictly three songs only but I had a drink with him in the bar and after that I was OK. You have to have a legitimate reason though, not just because you want to do it. If you approach people on a personal level and don't antagonise them, you can usually get what you want. With The Red Hot Chili Peppers, I really needed to shoot the whole show especially the last number with the hats with the flames coming out of them. I needed a range of photos of the whole band so I asked the tour manager, who conferred with the band, and I was given permission."

"Bryan Adams said one song and, for him, that was fine as I could get what I needed. Usually three songs is enough as that's about twenty five minutes or with Dire Straits, forty five minutes! With metal bands I'd prefer the last three songs as that's when they're really happening."

Occasionally Tony gets to tour with an act like The Big Day Out, Fleetwood Mac and, last year, Paul McCartney. In all there were eleven shows with McCartney and Tony was able to get shots from all over the venues as after three shows he had all the shots he needed from the pit.

"Their lighting was great but really weird," said Tony. "Lighting can often look aesthetically great to the audience but be really bad for the photographer. It's for you to get round that. There's a definite trend now for incredible light shows behind the band but not from the front so all you're getting is silhouettes. It can still look effective though. The The were difficult and The Cures lighting is a nightmare if you've never done them before, very limiting from a photographic point of view."

So far Tony has been able to avoid injuries



Tony Mott (left) with 'A Customer'

from over enthusiastic fans although whilst shooting a recent Smashing Pumpkins gig in Perth recently, the fans were throwing pumpkins at the stage which Tony only just avoided. In England Tony was at the Reading Festival when he noticed another photographer wearing a plastic mac and a crash helmet even though it was a hot summers day. Eventually he found out, in no uncertain terms, it was because the fans threw bottles of piss at bands they don't like.

*(Ironically it was at this point that Tonys cat decided to 'relieve itself' all over my hand-bag much to Tonys embarrassment!) Ha! -Ed*

"A barrier once collapsed at a PIL concert and that was pretty frightening," Tony recalled. "Luckily I managed to get wedged between two huge punks who decided to look after me! You're going to get hit when there's stage diving going on but once the audience have seen a camera in your hand, they tend to respect you and not deliberately hit you. They've paid to get in and it's their domain."

Tony works the shows on a freelance basis but usually having a magazine lined up or in mind for the sale of shots. He's just returned from The Big Day Out, doing live shots as well as backstage sessions, and he has sold the photographs to the USA - Rolling Stone, Spin, London - Melody Maker, NME, Vox, France - Best, Japan - Crossbeat and in Australia Smash Hits, Juice, Rolling Stone, Drum and Impress.

"I fax the overseas magazines before to tell them what I'm going to get" said Tony. "There's a lot of wheeling and dealing as many of the magazines are competitors. Obviously it's good for me when world tours start here and then go to England and the USA, like Paul McCartney and AC/DC. Soundgarden on the Big Day Out is going to be huge because their album hasn't even been released anywhere else so their photos will go well. If a tour ends here you're really doing it for pleasure or 'library photos'. I won't sell many of my Sting

photos but he's quite long term in appeal. I'll sell my Paul McCartney photos for the next ten years."

Tony also works directly with bands and management companies doing session shoots for publicity or album sleeves. To date Tony has done 194 single or album sleeves and he is particularly pleased with the work he did on Sonic Youths EP, Beasts of Bourbon Black Milk album cover and Tommy Emmanuel Dare to be Different album cover. Favourite live shots include PIL, Midnight Oil, Tex Perkins, and several Chrissie Amphlet photos.

"I think you take two absolutely phenomenal shots a year and then lots of really good ones," said Tony. "You can't expect more than two perfect shots and they are down to chance."

Tony will soon be going to the USA for two months to travel with the Lollapalooza tour, with Nirvana headlining, and then the Glasgobury Festival in the UK. •

# RADIANT

AUDIO ENGINEERING, INC.

**NEW RELEASE FROM THE U.S.A.**

**FINALLY!**



**A LOWER PRICED, HIGH QUALITY REPLACEMENT RANGE OF DIAPHRAMS & COMPRESSION DRIVERS**

**DIAPHRAMS \$150 INC.**

REPLACEMENTS FOR: JBL 2440, 2441, 2445, 2450, 375, 375H & 376

Distributed By:

**AUDIO & RECORDING AUSTRALIA PTY. LTD.**



PHONE : (02) 316-9935

FAX: (02) 666-3752

36-38 Daphne St., Botany, NSW 2019.

Write in Reader Service number: 128

# NewAudioNewAudioNewAudioNewAudio

**CADP2** is a prediction programme which can be used to create quick graphical 3D models of your design arrays and present results and recommendations to clients. This 2nd generation version supports DXF for AutoCad files, and works in Windows 3.0. CADP was first introduced in 1983. Call Jands (02) 516-3622.

**T.C. Electronic** are a highly regarded manufacturer of advanced pro audio equipment, and they are now represented in Australia by Amber Technology. The **TC1128 Programmable Graphic Equaliser** is the one Clair Bros. use, (see our Sting story this issue). Up to 32 units can be used together. Amber: (02) 975-1211.

**APHEX** have a new pair of products, the **Model 105** is a 4 channel, fully parametric gate

with click free operation. The logic assisted detector circuits provide positive operation. The **Model 106** is a four channel, intelligent compressor that varies the attack and release characteristics, dependent on the nature of the input signal. -East Coast Audio (03) 428-9797.

**SONY** insist the new **MDS-B1 Mini-Disk** recorder/player (right) isn't a mastering device. What it does do is provide exact and accurate recording onto the 74 minute, \$15 mini-disk - which we hear



is hot stuff for audio production, sound effects, and anywhere instant recording/editing is needed. Call Sony Pro Audio 02 887-6666.

**BEYER** have a new, affordable VHF wireless system, the **S250** offers a choice of handheld, pocket-pack or guitar transmitters with a mains powered true diversity receiver - an all metal, free standing unit. Retail prices start at about \$1500. Call Amber (02) 975-1211.

**SHURE** say the **VP88** stereo microphone is great for field recording, because it is rugged. Two condenser cartridges are mounted in a 'mid-side' arrangement, signals for the mid and side can be obtained directly, or combined into left/right stereo for 3D stereo imaging. Call Jands (02) 516-3622 for more.

## Corrections to AMID:

ACME Merchandising's phone number in their listing on page 121 of the AMID is incorrect and should be: (02) 587 5222. as it appears in their ad on page 120. Same fax: (02) 587 5554.

A# Sharp Recording Studio's owner/producer/engineer listing on page 227 is incorrect. and should read Jeff Cripps.

The Australian Music Teacher's phone and fax numbers as they currently appear in the AMID on page 104 are incorrect and should read: Phone: (03) 852 1111. Fax: (03) 852 1847.

The advertisement for Denyer Bros Pty Ltd on page 69 of the AMID contains the wrong address details. They are as per the listing on page 70: 118-120 Adderley Street, Auburn NSW 2144. Phone: (02) 748 6776. Fax: (02) 748 6754. The Australian Contemporary Mu-

# STUDIOS

HUGE SECTION: starts Page 38

# Maximum Power

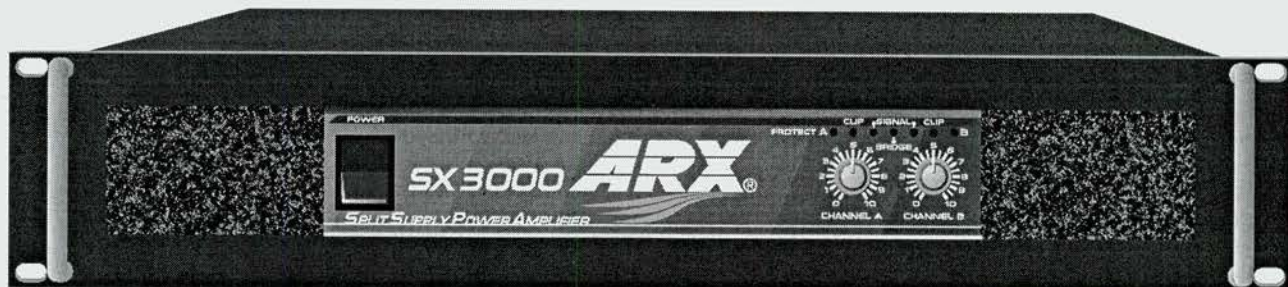

Continuously. No "Funny Class" voltage wobblers here! True High Power output, day in, day out.

Amplifiers designed smart to cope with the intensive duty cycle of today's productions. And not only High Power, but the right power, from a range that has a model to suit every application.

### SX500

200W per ch/8, 270 W per ch/4  
860 W Bridged mono 8 ohms

### SX800

300W per ch/8, 400 W per ch/4  
1050 W Bridged mono 8 ohms

### SX1500

490W per ch/8, 700 W per ch/4  
1920 W Bridged mono 8 ohms

### SX3000

660W per ch/8, 1000 W per ch/4  
3000 W Bridged mono 8 ohms

Sound interesting? If you'd like to know more about the newest, most exciting range of amplifiers around, call any of the people listed below. They'll be happy to help you.

Victoria and Tasmania: Tony Hosking 03-888 6555; New South Wales: 02-879 6788 Dave Croxton; Queensland: 074-424 233 Rod Watts; South Australia: 08-356 6601 Peter Aszталos; Western Australia: 09-354 3185 Ian Ross; New Zealand: +64 (09)9 378 9863



ARX SYSTEMS P/L, 33 ADVANTAGE ROAD, HIGHETT, VICTORIA 3190, AUSTRALIA. PH: (03) 555 7859 FAX: (03) 555 6747

# moves

□ **Dave Adams** from BOSE is now Sales Manager, Professional Products, US Export Pacific Territory, which means he doesn't work from BOSE Australia any more, and will travel relentlessly. Hopefully he can remember us all at home and send us information from time to time. A nice guy too, good luck!

□ **Advance Booking Agency** have moved, Tony Brooks and Julie Conway can be reached at a new phone number: (02) 660-5485.

□ **David Riddell** has left The PA People (Brisbane) where he was pro sales person for 6 years. Now he operates as D.R. Audio, and will do audio course instruction, freelance live engineering and install work. Call paging service (07) 361-7111, pager number 403-010.

## Get a lawyer!

We've got TWO handy print guides here that might save your bucks next time you need legal help.

• First up, a guide called "Not Just Any Lawyer", which is free, and which is aimed at convincing you to join the Australian Law Access scheme, which in exchange for a subscription fee, entitles you to immediate phone access to lawyers for initial advice on your predicament. In any case, call 1-800-803-845 for a free copy.

• Then we have a book called "The Guide To Australian Lawyers" (\$35 from Butterworths, 02 232-2777) which is a 222 page guide to WHO will handle WHAT, across 48 subjects. It is very handy, we've already used it to find lawyers who've advised us on certain delicate matters of a defamatory nature ...you may find it handy too.

*Space running out,  
Workshop demand high,  
Awards announced*

## ENTECH '94 BOOMING

With the announcement of the ENTECH AWARDS, attention is squarely focussed on Sydney for the first ever Entertainment Technology Trade Show, to be held October 6 through 8th this year.

With over 50,000 square feet of exhibition space in the Darling Harbour Exhibition Centre more than 80% sold, the organisers, Connections Publishing, have turned attention to promotion, vowing to 'do it big'. Admission to ENTECH is free to the trade.

The Entech Awards are the first true 'User Votes' technical awards process for Australia. Connections say they will bear the estimated cost of the Awards themselves, estimated at \$30,000, without compromising by enlisting sponsors.

A programme of affordable workshops is being prepared, for release in May. Call (02) 876-3530.

sic Institute's address is incorrect on page 75 of the AMID and should actually read: Australian Contemporary Music Institute. Faculty of Arts, Southern Cross University, PO Box 157, Lismore NSW 2480.

Sharon Blank Management's address on page 99, is incorrect in the AMID and has changed to: 37 Clarke Street, Northcote, Victoria 3070. Phone/fax: (03) 489 9336.

A correction needs to be noted to the listing in the Asian section of the AMID. In Regional Offices under BMG International the contact name for A&R/Marketing should in fact be Stuart Rubin, and not Dwayne Welch, as is printed on page 4, in the Asian section.

Australian Audio Supplies, listed on page 141 of the current AMID have a new phone number, that being: (02) 879 6124.

*(continues over)*

# CONTRACTING

NEW SECTION: starts Page 62

## THUNDERBOX BASS THAT WON'T BLOW THE BACKSIDE OUT OF YOUR SPEAKERS



**APHEX BIG BOTTOM™** delivers a massive bass sound with virtually no increase in peak output. You need no extra amplification, no extra speaker protection, no overload distortion. Just a very big bottom end, dynamically processed and optimized to enhance the perception of a deeper meaningful bass. Welcome to the all new **APHEX AURAL EXCITER TYPE C<sup>2</sup>** with **BIG BOTTOM™**. A quieter, more musical and easier to use excitement revolution for high AND low frequencies. Contact EAST COAST AUDIO now for the name of your nearest APHEX stockist.

Contact **EAST COAST AUDIO** now for the name of your nearest APHEX stockist.  
Phone (03) 428 9797 or 018 381 481 or Fax (03) 427 9898.



Broadcast Technology Pty Ltd. A.C.N. 005 689 752. wch4646.

Write in Reader Service number: 135

# Bits

◆ **MIDAS** won best mixing console with the XL-3 at the LIVE Tech Awards '94 in London....

◆ **BBC World Service** has ordered a **NEVE Logic 1** digital mixing console, which makes console # 7 for them. Syncrotech Systems handle Neve here, call (02) 417-5088.

◆ **ARX** have appointed new distributors in Greece, France & Brazil, and scored some success with major sales in Hungary. Jozsef Palfi from P+P Music will refurbish the Big Madach Kamara Theatre with ARX signal processing.

◆ **HSV7 (Melbourne)** has a new **Fairlight MFX2** Digital Audio Production System, it'll be used in the main Audio Post suite for laying up effects and music tracks.-Amber (02) 975-1211.

◆ **CC's Stage & Studio** are now ARX dealers, the recently opened South Melbourne shop is a new audio showcase of some magnitude, call in to 538 City Rd. CC's at Morrabin are still there, cookin' chips!

◆ **Soundtracs** new Solitaire Production Console will debut at Frankfurt Messe-Turm this month, it's a 24 buss, in line console with dynamics.

## NewAudioNewAudioNewAudio

### AMPLIFIERS:

**AUSTRALIAN MONITOR** announce ten new models for 1994, starting with the studio version of the AM1600, the AM2100 Monobloc, K88 (2 x 450w) & a THX version, 1K2 studio, C600-C800 and C1200 contractor models, and the Opal2802. More amps than you can poke a stick at. Call them: (02) 8816-3544.

**JANDS** say the MKII versions of their convection cooled 107/104 Series amplifiers (right) are not just quiet, but also ideal for contracting. They have clean and simple internal layouts and minimal link wiring, with rear panel switches for bridge or parallel operation, looping XLR input connectors, spring loaded speaker terminals, volume controls and clip LED's. 200w/ch from the 104, 340w/ch from the 107. Call Jands (02) 516-3622.

**CELESTION** unveil the SRA Series power amps, with Celestion's dual rail 'soft switch' output stage, employing linear, output-derived Class G amplification. The soft switch design means that the switch to the upper rail is inaudible and seamless to the point of being invisible to distortion measurements. (as should be! -Ed). These are tough

looking amps, the SRA 1000 delivers 510w into 4Ω, while the SRA 1600 does 815w. The fan filters and tamper proof bridging and ground lift switches are front accessible, so no amp rack removal required. Out back are parallel latching XLR's for daisy chaining and Neutrik Speakon's. Amber: (02) 975-1211.

**PEAVEY** have new amplifiers, the VX range joins the PV series, and the famous CX series. With projected prices of less than \$3000, these top of the range VX models offer a lot of power-to-bucks. The VX 3.0 delivers 1000 watts per channel into 4Ω, and will handle

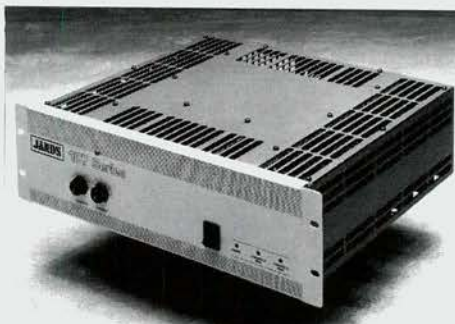

2Ω loads as well. It is 3 rack units tall, has 2 speed fan cooling, and both 6.5mm and XLR input connectors. The VX1.5 delivers 550 watts into 4Ω, is 2 rack units tall, and like the 3.0, has binding post speaker outputs. Both amps accept PL-2 transformer modules. Call Australis: (02) 938-3466.

Danny Keenan who was working at Brash as Promotions Manager has left the company. In addition the current phone and fax numbers for Brash Power Picks magazine in AMID on page 104 are incorrect and are in fact: Phone: (02) 744 5478. Fax: (02) 744 5519.

A number of corrections need to be noted for the Concert Lighting Systems Australia P/L listing in the current AMID. On page 55, in the Concert Production section, it should be noted that the Production Manager is in fact Tim Hall and not Phillip Robinson, while the Operations Manager, not listed is Louise Brennan. On page 142, in the Professional Audio, Musical Equipment Distributors section the suburb should read "Port Melbourne" and not "Port Macquarie". Production Manager is Tim Hall and not Richard Grenfell, as listed. Accountant/business Manager is Anna Angelico-Baker. On page 151, in the Professional Audio, Musical Equipment Retail and Hire section the suburb once again should read "Port Melbourne" and not "Port Macquarie" as it does currently. In addition it should be noted that the Production Manager is in fact Tim Hall and not Richard Grenfell and that Accountant/Business Manager is Anna Angelico-Baker.

.....



## COUNTRYMAN ASSOCIATES INC. ISOMAX HEADSET MICROPHONE

"the hands down headset winner"

### Features:

- Dynamic warmth-condenser clarity
- Cardioid or hypercardioid pattern
- Phantom powered version has pop free switch in connector
- Special version available for direct powering from wireless transmitters
- Snug, comfortable fit
- Headband fits around back of head for minimum visibility
- Telescopic, adjustable mini-mike boom
- Withstands 150 Db SPL!

### Options:

- **Wired** Phantom Powered
- **Wireless** Specify Transmitter Type
- **Versions** Hypercardioid, Omni-Directional, Aerobics (Omni, Water Resistant)

### Specifications:

- **Frequency response:** 20Hz-20kHz
- **Sensitivity:** -57dB re. 1 Volt/Pascal
- **Output Impedance:** 600 Ohms Balanced (Phantom power model)
- **Overload Level:** 150dB SPL @ 1% THD
- **Power Requirements:** 15v
- **Battery Powering Module Available.**

### Applications:

- Vocals: (Drummer/ Keyboard Player)
- Theatre: as used on J. C. Superstar

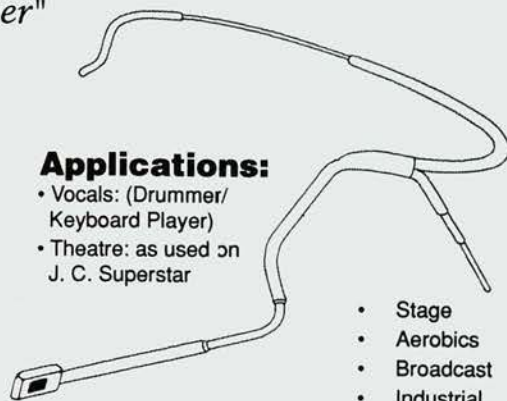

- Stage
- Aerobics
- Broadcast
- Industrial

## PRODUCTION AUDIO SERVICES PTY. LTD. ACN 006 149 499

**MELBOURNE:** 5 Feather top Ave., Lower Templestowe, Vic. 3107  
**SYDNEY:** Suite 407, 220 Pacific Hwy., Crows Nest, NSW 2065

Ph: (03) 852 0900 Fax: (03) 852 0422  
Ph: (02) 954 5100 Fax: (02) 954 4927

# NewAudioNewAudioNewAudio

## MIXING CONSOLES

**MACKIE** consoles have been reduced in price—the CR-1604 and the MicroSeries 1202 both fall by \$100 retail. The importer states "the strengthening of the Australian dollar and desire by Mackie to attack head-on the clones and competition entering the market. Call *Australian Audio Supplies*, (02) 879-6124.

Mix more, mix **SOUNDCRAFT**: they

You can hook up a PC to display graphical representation of the effect. This is a good idea, we think. It has Quasi parametric EQ and eight aux sends. (*Not enough -Ed*) This console will probably be on show at ENTECH '94, as will all the others noted here, we hope. Call Amber, (02) 975-1211.

On-Air Consoles from **Soundcraft**, the new MBI Series 5 is a fixed format design offering 4 mono, 6 stereo and

2 telephone inputs, with master facilities, and the MBI Series 10 is available in a 24 module width frame with 20 input channel capacity and a 32 module

width frame for more inputs. It includes a choice of mono, mic/line, stereo line/line and telephone inputs, with or without EQ.

More ... **Soundcraft LM-1** is a portable mixer for on-location, film or broadcast work. It works on DC 8-30v or inbuilt batteries that go for 18 hours. It appears to come in three sizes, 6, 8 and 12 channels. *Jands can tell you more*, (02) 516-3622.

**CREST** Consoles are kicking along in the north-world, they also own **GAMBLE**, who make mondo-grouse top end concert consoles by hand. Encouraged by sales of the Century series, the firm has announced the LM Monitor console, with either 12 send MONO for up to 52 inputs, or a STEREO variant that will supply 8 stereo and 4 mono mixes. Both models have passive internal microphone splitter systems. More about these when we hear more. *Production Audio Services handle Crest*, call them: (03) 852-0900.

now offer the Folio

4, yet another budget mixer, affordable, but the news release doesn't say what the price is. It has 12 mono and four stereo channels. The release doesn't mention the EQ or auxiliary sends either, but the EQ is probably the same as the others, ie: mid range sweep on the mic input channels. Call *Jands*, (02) 516-3622.

**PHONIC** are getting it together, the new 4 buss range have six auxiliary sends, with mid-sweep, 3 band EQ, and multiple output possibilities. The prices are just unbelievable, \$3,395 for the 16ch, and \$3,995 for the 24 - with 3 year warranty to boot. Call *Pat Bonham at CMC*- (02) 905-2511.

**SOUNDTRACS** unveil a major new Live Sound Console, the Sequel 2 (above) has eight groups and eight VCA groups. In addition, a very cunning assignable dynamics facility exists whereby you can apparently assign an onboard noise-gate, compressor, auto-panner, modulator or combination thereof, to EACH channel.



  
**MUSIC MI**  
**NEWS & UPDATE**  
NEW SECTION: starts Page 75

  
**LIGHTING**  
NEW SECTION: starts Page 53

# MC

AUSTRALIA

## MULTI-CONTACT AUSTRALIA

Specialist cable and connector suppliers to the sound and lighting industry since 1975

### Distributors for :-

#### Multi-Contact

Insulated circular single pole locking connectors to 1000 amps.

#### Contact

Rectangular multipole lighting connectors- screw or crimp.

#### CEEP

Circular Connectors, (Socopex compatible)

#### Kroschu

Highly flexible multicore lighting cables 0.5mm<sup>2</sup> through to 2.5mm<sup>2</sup>

#### Kroschu and Lapp

Highly flexible silicon rubber cables

#### Lapp

Tough, abrasion proof, polyurethane sheathed multicore cables.

Carol & Multi-Contact  
Foil or braid screened audio, data, and control cables.

#### Carol

Rubber sheathed microphone cables

#### N.E.K.

Video cables and triaxial camera cables.

## MULTI-CONTACT AUSTRALIA Pty Ltd

SYDNEY PH (02) 438-3600  
FAX (02) 438-4737  
MELBOURNE PH (03) 383-3733  
FAX (03) 383 4526  
PERTH PH (09) 249-3003  
FAX (09) 249-4912  
BRISBANE PH (07) 856-4200  
FAX (07) 856-4681

## Phil Tripp Writes....

The access of the music industry to government—particularly the professional technical area that governs studios, concert production, audio, lighting and musical instruments—is going to be crucial for survival in the next few years. If the talks at the Melbourne National Music Conference in mid-February are any indication, there's been no progress but there is about to be.

A breath of fresh air in the Federal Government who may be a hurricane of hope for our industry is the new Minister for the Arts, Mr. Michael Lee, who spoke to the 100 or so assembled at a series of forums staged as part of the Melbourne Music Show. Where the federally funded and convened Music Industry Advisory Council (MIAC) has not only ignored but also not had representation from the professional/technical sector, presenting the needs and voice of the production sector may be done through a direct representation to Minister Lee.

What makes this Minister a likely hearer and possible hero for our industry is the fact that he actually likes contemporary music at 36, spent his share of nights at rock gigs, but most important, he has the Communications portfolio as well as Tourism under his control. But it was his informed talk to the industry, his candour about areas of need in development as well as his lucid and honest answers to questions from the audience that show his potential as a great friend to the industry.

**MIAC BYPASSED.** What has come out of this is a committee of around a half dozen people who will be taking the trek to Canberra to further the dialogue that has already started. It will be done without the influence of the major record companies and their lobbyists and it will sidestep the confused and generally unresponsive MIAC which seems to be ignorant if not dismissive of the professional/technical sector—opting instead to cater to the needs of the major forces, copyright anomalies and export potential.

I know this might be a little boring to you but there are some critical areas that need addressing in our industry. For example, what kind of assistance can be given to boost exports of our audio, lighting and musical instrument trade? Also, we have a large number of producers and engineers from overseas who are coming here on holiday visas, promotional visits or other business trips yet they are working here without permission, taking work away from local talent. At the same time, some of our best talents are being poached by Asian interests at the same time that the local studios are not getting any assistance to bring in Asian artists to record here. There are an enormous number of other issues which will not see the light of day unless someone represents the live music sector and the recording arts rather than simply the artists & songwriters.

The latter point is a real sticky one. Export Music Australia has spent vast sums—and received back significant amounts back from the Federal Government through the Export Development Grants Scheme—in promoting a limited number of artists

in the U.S., Japan and with a view to cracking Asia this coming year. But because of its brief and the patronage of ARIA, APRA and AMCOS, EMA has had to keep focused on artists, not the export potential of the 'industrial' sector.

Which brings me around to MIAC and what it is doing for the industry. MIAC would like to have you believe that it is an industry initiative—it's not, it is very simply a study group reporting to the government. MIAC would like you to believe that it can, through a series of very expensive studies by Price Waterhouse and other research firms, represent our interests to its government minders. They addressed contemporary country music by having Slim Dusty's wife on the MIAC committee. Yet they've never even sought nor answered requests from the industrial sector of the music business to address its needs.

**'BORING PIFFLE'.** The key reason for this appears to be the MIAC overseer, Kim Wilson, who admits he was hired to head up MIAC because he knew nothing about the music industry. He'd previously headed up the Broadcasting Tribunal and is perceived, from his performance at the National Music Conference as being pompous, boring, condescending and patronising to those who had the misfortune of listening to his piffle over two days. At least that's my review and the views of a few others who endured his 'masterplan' for the industry as revealed at the 'Government and Music' forum.

MIAC has representation from record companies, managers, publishers and the major music industry associations and they've just added members from the Musos Union and Media Entertainment & Arts Alliance. But it is operated by unpaid people who volunteer their time (with the exception of Wilson) and its effectiveness is in question as far as the hard work side of the industry is concerned.

So going through the Minister for the Arts may be the logical sidestep to get an appropriate ear and action. In the next month, I'll be compiling some courses of action, areas of concern and other input that I receive from industry sources to convey to Michael Lee as well as to route through other relevant government bodies from Austrade to state business development organisations.

In New South Wales, Minister Peter Collins has announced another \$50,000 grant scheme for Rock Music Initiatives. In Victoria, the Victorian Rock Foundation is working with the state government to develop business assistance initiatives. While on the national front, AUSMUSIC is struggling to survive with an \$800,000 funding deficit. WAM just lost its general manager. South Australia has appointed John Schumann (ex-Redgum) to co-ordinate industry activities in that state. So what are YOU doing? Please drop me a line and let your suggestions and comments pass through to the government before time runs out. •

*Fax your comments on (02) 211 5938 - or mail to Phil Tripp 3 Rose St., Chippendale NSW 2008*

## AUX 2 Gossip

We had a saucy article coming from TOPSTAGE PRODUCTIONS (A.C.T.) chief Steve Devine, who promised such salacious material as: 'Great holidays I've had on Creditors Money'. 'Why have one bank when you can have fifty'. 'The philosophy of OPM (Other People's Money)'. 'Stalking your bank manager (The principle of floating multiple cheque accounts)'. and: 'Corporate Structure and how to make it impossible to be sued'. Sadly Steve has failed to deliver, perhaps he realised a hardback version would be a serious sales success instead!

Lenny Kravitz wins the dressing room of the year award, it seems he enters this heavily decorated pad at 3pm, and is still there well after 1am. Then there were the HUGE number of backstage passes handed to pretty young things by a minder .....

Martin Hansford departs his permanent audio position at the Opera House to work with 'Wombat Tracks' music & audio production based in Newcastle. G'luck MH.

A1 Audio Pty Ltd chief Chris Kennedy made specific threats against this magazine after we published a story of woe about A1 Audio last August - it now transpires the firm was in fact deregistered by the Australian Securities Commission in June 1993. The firm didn't lodge an annual return ever in its six year history, and still has creditors unaware of the de-listing. Furthermore it seems Kennedy breached company law by continuing to trade as A1 Audio after June - we hold a letter from A1 sent in August. Anyone knowing more is invited to call us. Several creditors will soon apply in court to have the firm put back on the company register for the purposes of appointing a liquidator.

Gary 'Squirt' Brockenshire is freelance again after Arena Technical Services sold out last month. Squirt will P.M. the Santana Tour for Mr Dainty, and can be reached on (02) 997-6144, or 018 417 866.

# Value

means a lot more than  
Phonic's low prices and our  
**3 year warranty...**

**VALUE** now also means  
uncompromising features!

## VALUE 4 BUSS MIXERS

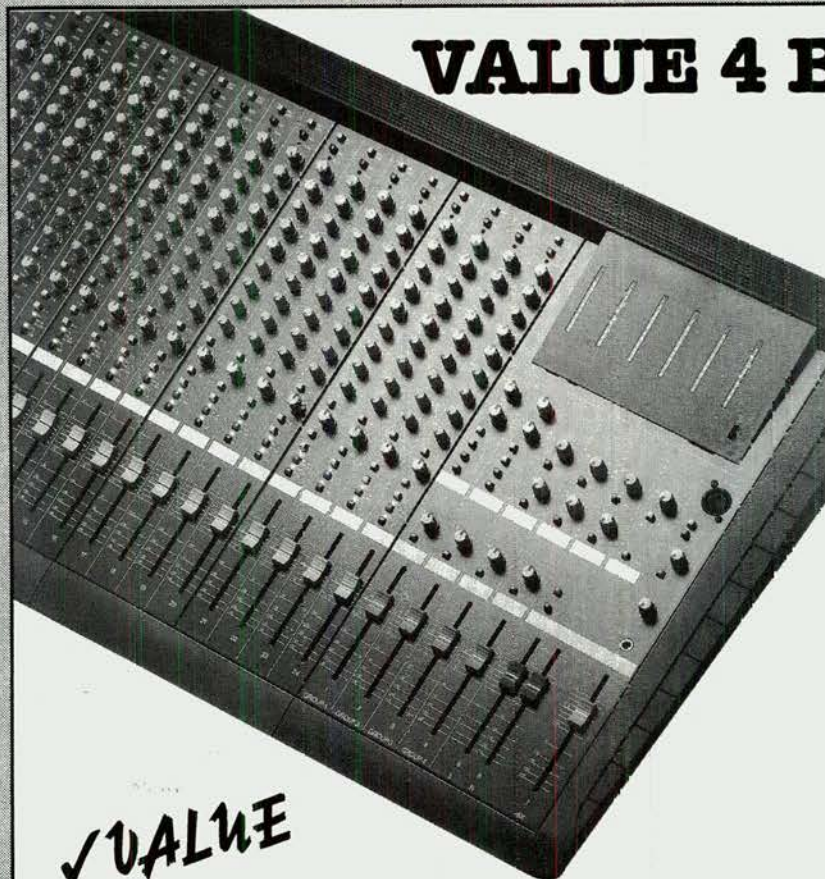

- ✓ Sweep EQ
- ✓ Four Subgroups
- ✓ Two Stereo returns
- ✓ Seven balanced XLR outputs including groups
- ✓ Independant mono output
- ✓ Dual alternate output switchable from every channel
- ✓ Insert points everywhere
- ✓ Alps long-throw faders
- ✓ Six auxilliary sends
  
- ✓ **LOW NOISE**

16 CH: M-1642 \$3,395

24 CH: M-2442 \$3,995

retail incl. tax at 15/2/1994 (Subject to change)

✓ **VALUE**  
**PHONIC**®

From C.M.C. Call (02) 905-2511, Fax (02) 905-0189

Write in Reader Service number: 149





**FOLIO 10/2:** New ultra portable compact console with 6 mono microphone channels, each with gain control, 3 band EQ with swept mid, hi-pass filter, 2 AUX sends, pan control and 60mm linear fader. Two stereo input channels each with 2 band EQ, AUX sends, pan control, fader and switchable input gain +4/-10dB are also provided. All this and performance: 108dB dynamic range!

Phantom power for condenser mics, PFL solo buttons, 2 AUX sends, separate monitor outs, stereo inserts across the mix-outs for graphics etc, stereo tape returns and oscillator for level matching.

**FOLIO 10 CHANNEL**

(6 mic. inputs and 2 stereo input channels)

**FOLIO 12 CHANNEL**

(8 mic. inputs and 2 stereo input channels)

**FOLIO 12 RACKMOUNT**

(8 mic. inputs and 2 stereo input channels)

~~\$1495.00~~  
**\$1795.00**

**\$1795.00**

**FOLIO SPECIAL**  
10 ch. was \$1,495  
Now **\$1,195**

**Folio 4**

**FOLIO 4:** Live mixing console, building on the highly successful Folio. This console provides professional front-of-house mixing facilities at an amazingly low price, with 12 mono and 4 stereo input channels, true 4 buss discrete sub-groups, routable to mix, 8 AUX sends and all the facilities required to provide a professional mix. The Folio 4 is provided in a 20/4/2 format, with 12 mono input channels each featuring a mic/line input, phantom supply switch, gain control, insert points, 3 band EQ with swept mid, hi-pass filter, 8 AUX sends, group routing, PFL solo switch and peak LED. Four stereo channels are also provided with similar facilities as the mono channels but with 2 band EQ and switchable input gain (+4/-10dB). 2 stereo send and returns, subgroup AUX control, dual LED "look and listen" flexible multiple metering, oscillator, XLR mix outs, stereo tape send and return, stereo monitor outs, latching 4 pin XLR power supply are just some of the other features of this console.



**\$3995.00**

**TIPS**

**PA Mix**

Set up the backing vocal mics and check that there is no feedback problem: when both the backing vocal and lead vocal mics are on. If there is, reduce the master gain setting slightly until the feedback stops. If feedback is a real problem, consider moving the main PA speakers forward a little.

Now the instrument mics and direct line inputs can be balanced relative to the vocals.

Finally, test out any effects units connected to the system and establish the correct balance of dry and effected sound.

Avoid excess use of EQ as this can encourage feedback and may also spoil the basic character of the sound. Consider it an aid to fine tuning rather than a means of making radical changes. It is also recommended to use the high pass filter wherever possible, except on low frequency sources such as bass guitar and drums.

The use of stage monitoring can also worsen the feedback situation so run these at the lowest volume the performers can comfortable work with (from Spirit Folio Applications Guide. Contact Jands for a copy).

**Folio Si**



**FOLIO SI:** Primarily a keyboard mixer but suitable for anyone using stereosources. Specifications are as per the Folio 12/2 but with 8 stereo channels and 2 mono mic/line switchable inputs, giving a total of 18 inputs. Fixed 3 band EQ on stereo inputs with swept mid on mono inputs. Latching PFL solo buttons, available either as flat-bed desktop mixer or in a 7RU rackmount format.

**\$1795.00**

**FOLIO PORTAPOWERS:** Battery pack connector which enables any Folio, except Folio 4, to be run from 11-18V DC battery source, eg: a car battery.

**\$445.00**

## Readers Tell Us ....

**Marc Kelly** of **Creative Vision Productions** in Shortland NSW asks that we advise the addresses of Light & Sound International magazine, and Live Sound & Touring Technology. He reports 2 people read his issues of Connections. •*For anyone who'd like to subscribe to these, their addresses are: L. & S. I: 7 Highlight House, St. Leonards Rd, Eastbourne, East Sussex BN21 3UH England, (fax 323 646 905) and: Live: 35 High Street, Sandridge, St. Albans, Herts AL4 9DD England, (fax 727-44-417)*

**David Gibson**, a sound engineer/record producer of **Copperfield Sound Productions** in Broadbeach Queensland suggests more technical articles on latest trends, techniques and equipment used in both the audio and lighting fields. 3 people read David's copy. •*Technical articles are always sought and welcomed for consideration - why not write one?*

**Simon Olafsen**, a freelance lighting and audio engineer from Salisbury Plain in SA suggests we use a spellchecker. 4 people read his copy. •*Editor asks anyone knowledgeable to advise regarding this thing called a spellchecker, how it works, and how much it costs!*

*TCP Letter (continued)*  
gether a truly spectacular event.

- A daily management team comprising James Still (Pro A/V and Chuck Gard (Seaworld Show and Entertainment Manager) was formed to co-ordinate this enormous team and to stage manage the shows which ran nightly for five weeks.

- The show became a massive production involving Seaworld engineering team, management, pyrotechnics team, skiers, boat and helicopter drivers and all contributed to the huge success of this show.

- **Total Concept Productions** and **Professional Audio Visual** as their Queensland agents for lasers, have a long standing history of successful joint venturing in projects in Queensland, and are both proud to have played a major role in the Seaworld "Serpent Slay-ers" experience.

- **Anthony Musico, Total Concept Products Pty Ltd.**

## Intolerant, snide, unpro....

Your response to my letter last issue said, "PLEASE let me be wrong". OK, YOU'RE WRONG! How could you possibly read into my letter ANY suggestion that you should make snide remarks about ANY group of people it beyond comprehension. The only explanation I could think of, was perhaps you read it late on a Friday afternoon, after the yipee juice cabinet was opened?

For your information, I've been

happily working and associating professionally with gay people for many years, and have not found it necessary to be nasty to any of them. Just because I don't agree with their lifestyle, doesn't mean I can't work professionally, and closely, with them or anyone else.

You said you couldn't find any comments regarding Christians in back issues. Let me refresh your memory: 1. Connections; April '93, page 24 - "Hire Biz Buzz" - presumably by J.G.: "Doug also suffered (sorry, wrong word, start again...Ed) Doug SNEAKED IN a Youth Alive rally in Cairns before leaving". 2. Connections: August '93, page 14 - "Sex, Drugs, Rock and Religion" by J.G.: "first I exchange a few pleasantries with the band who, I've recently been aghast to discover, are of the Pentacostal faith".

Careful Julius, your intolerance is showing.

By all means, you're entitled to your private opinion of anybody and anything, but don't you think it's just a tad unprofessional to put negative comments about people into print, just because of what they believe?

The trouble is, through all of this, you seem to have totally missed the point of my original letter, which was very complimentary towards your magazine. My thoughts there haven't changed - all I'm asking is, please, cut the crap when talking about Christian gigs - talk about the audio and lighting, but you don't have to denigrate the people, just because

you don't believe in what they do.

Why don't we all forget this now, and get on with producing the best shows possible for the punters - WHOEVER THEY ARE!

-**Peter Robins, Adelaide.**

*\*Sometimes I wish we made up our own 'letters to the editor' like some other mags do. It'd be less stressful. Peter also slipped in a 'breach' (is that a sin?) from Channels, but that's ancient history and a different circumstance.*

## More Humility required

In response to the "don't make snide remarks about Christian gigs" paragraph in Mr P Robbins letter of February 1994 I say this:



When working as a stock controller in a music store recently I was continually amazed at the propensity for *some* churches to buy large amounts of new equipment. As members of a "religious club" their purchases were exempt from sales tax.

Gez Peter, I wish me and my buddies had a good enough reason to form a club that could trade without paying taxes. Anyway I only hope, for your sake, that you'll be able to fit through the "eye of the needle" when burdened by the "\$40k-\$70k a year" you so flagrantly waved in our faces.

Other than that, keep up the good deeds, and remember - MORE HUMILITY- always.

- **Brucco, Harlequin Sound, Sydney, NSW.**

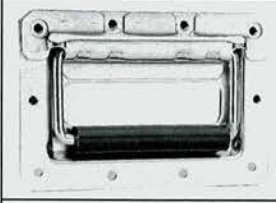
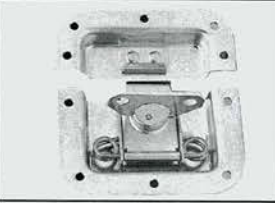
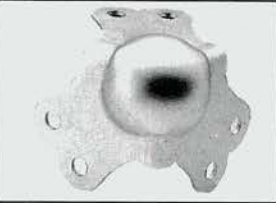
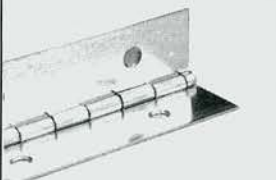
.....

			<p>Where do you go for the World's largest range of Flightcase Hardware ?</p> <p>Australia's #1 Supplier.</p> <p><b>PENN FABRICATION</b> 43-45 Johnston St. Port Melbourne, Vic. 3207 Ph:(03)646-7222 Fax:(03)646-8222</p>
			

CIRCLE 142 ON READER SERVICE CARD

# Hot and Sweet!

The New Audio-Technica

## Hi-ENERGY

Dynamic Microphones

### More Than Just Specs

The new **Audio-Technica Hi-Energy Series** have much more going for them than just advanced high output design. Of course there's a large diaphragm, plus a large voice coil with lots of turns in the gap and Neodymium magnets for greatest efficiency. But then we use this high energy to create a great sound.

### The Vital Inside Differences

For instance, we use a tangential surround to insure linear movement of the low mass diaphragm. The voice coil is copper-coated aluminium for both high conductivity and low mass needed to respond accurately to highs. Plus unique internal resonators that further smooth out response for a well-balanced, very sweet sounding performance.

### The Dynamics That Think They're Condensers

The final sound of the **Hi-Energy Series** is far more like a condenser than a dynamic. With a full-bodied bottom end that makes just about

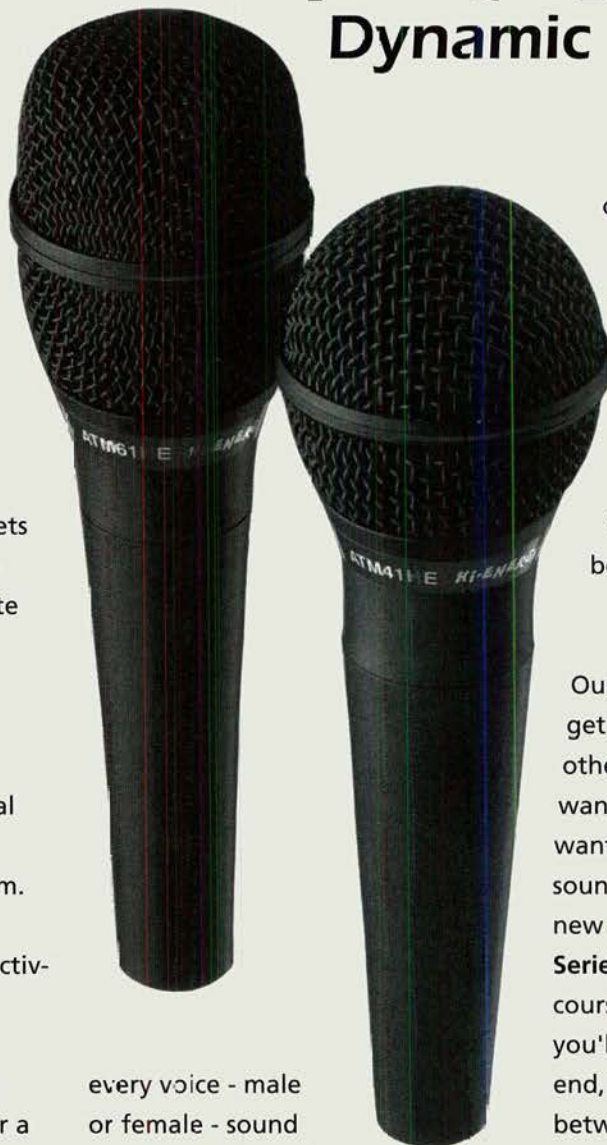

every voice - male or female - sound great, plus clarity that just cuts through even when everyone else is playing at "11"! And, they sound great on drums and instruments too.

### Quiet Please

With the **ATM61HE**, **ATM41HE**, **ATM63HE** and **AT828HE**, we've

controlled the high handling noise that plagues many large diaphragm dynamic mics. We use a very sophisticated 3-stage mechanical filter between the element and microphone body. What little noise remains is far less intrusive. The difference can be very dramatic.

### The Choice Is Simple

Our mics are very affordable - you get a pro mic for the price of the others' cheapies. So, whether you want the extra loudness, or just want a great, reliable, sweet-sounding vocal microphone, try the new **Audio-Technica Hi-Energy Series**. Listen for loudness, of course. But then *listen*...to how you'll sound up on stage. In the end, your choice may just be between the **Hypercardioid ATM61HE** and **ATM41HE** or the **Cardioid ATM63HE** and **AT828HE**. Anything else is just loud.

See and hear the Hi-Energy Series microphones at selected **Audio-Technica Dealers** or call our Information Centre toll-free on **(008) 80-6266** for more info.

 **audio-technica**

Yamaha Music Australia 17-33 Market Street, South Melbourne Victoria 3205

Tel (03) 699-2388 Fax (03) 699-2332

Write in Reader Service number: 130

# CLAY PAKY FOR GOLDEN SCAN 3



**THE**  
**LIVE!**  
**AWARDS**  
**1994**

*Automata Luminaire*

**AWARD**

*presented to*

*Clay Paky  
for  
Golden Scan 3*



# TIGER MULTICOLOR

# GOT ONE?

Shame! Because...

Scanners on their own aren't enough to set a scene. They give it light, coloring the beat of the music, but the chromatic washes created by color changers are essential to create real "atmosphere". **Tiger Multicolor** gives you all this and much more. Fantastic colors produced by the purest dichroic filters, concentrated and evenly diffused light beams, gradual fading from zero to 100 percent, a strobe effect, functions which can be programmed from any control unit that uses analog or digital signals, including the DMX 512.

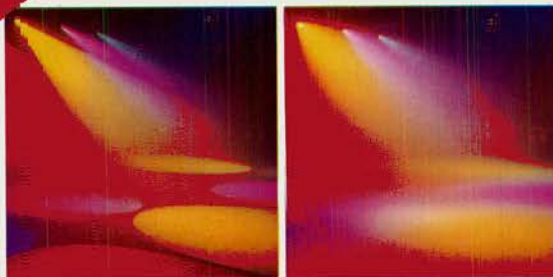

Thanks to its powerful discharge lamp, one **Tiger Multicolor** is the equivalent to a whole bank of conventional color changers. What's more, the same amount of effects can normally be produced only by a complex system of spots, color scrollers, gelatine filters, strobes and yard upon yard of cables.

**Tiger Multicolor**, on the other hand, is a simple, complete and economical solution. You won't need dimmers there are no gelatine filters to change and the lamp life exceeds 750 hours!

**Tiger Multicolor:** fantastic color effects and all the power you need plus the benefits of an intelligent investment.

*Distributor for Australia:*

**SHOW TECHNOLOGY AUSTRALIA PTY LTD**  
13 - 15 Bridge Street - Rydalmere NSW 2116  
Phone (02) 898 1 11 - Free Call (1-800) 64 6566 - Fax (02) 898-1222

*Head Office:*

**CLAY PAKY SPA** - Via Giovanni Pascoli, 1  
24066 PEDRENGO (Bergamo) Italy  
Tel. 39 - (0) 35.663965 - Fax 39 - (0) 35.665976



PROFESSIONAL SHOW LIGHTING

Write in Reader Service number: 151

## The Big Box Builder is Back

For speaker enclosures and custom cases,  
Call Ian Stewart.  
Phone: (02) 798-6539, Fax: (02) 798-6571  
Ramtek Industries Pty. Ltd.  
34 Bartlett Street, Summer Hill, NSW 2130



## Hire Point Software

Efficient, well managed, hire & production operations in this industry use **Hire Point** software.

100% Australian and now exported to the U.K, U.S, N.Z and Canada

Use anything else and your just playing games.  
Phone now if your serious about computerising  
Ph : (02) 876 2745 Fax (02) 869 1495

## BURKINSHAW CONSULTANTS

"For all your staging needs,  
Hire, Sales and Production"

12 Budgerie Place, Hoppers Crossing, 3030 Victoria, Australia  
Tel: (03) 748 6864 Fax: (03) 748 8193  
Phone Phil: 018 386 481

## STAGING RENTALS

Extensive Range of  
Rental Drapes  
Risers & Flats, Scenic Art  
Delivery & Installation  
**(02) 519-6300**  
Fax (02) 519-6489

## Colin Baldwin

Lighting Design  
Lighting and Stage Design for  
Concerts and Special Events

Phone (02) 878-1799 Fax: (02) 805-1003 A/H (02) 653-2038



## AROUND & ABOUT .. with Caroline Grafton

**FERNANDEZ MUSIC CENTRE - Cairns QLD-** Mark Williams completed the huge gig for a double ordination at ST. MONICA'S CATHEDRAL where the Bishop asked for more foldback to supplement the inhouse system. "There's thrash-heads in every business" says Hire Manager Doug Johnstone".

Doug continues, "We also had a big hire to Cairns Police SWAT Team during a four day siege. Lighting and hi-powered microphones were used to listen in on the offender. None of the police or our equipment was damaged during the shoot out!!" *Bummer!*

If you're planning a trip to Nth. Queensland and you fancy yourself a bit of a golf player, Phil Cadera and Doug Johnstone are taking on all challengers in the Sega Masters, so get your putting practice in before you get there, because these boys reckon they are deadly!! Call Doug or Mark on (070)51-8519.

**ACTIVE LIGHTING Hawthorn, VIC -** have added a Scan Commander into their hire production dept. and say, "Scancommander has been used to run Goldenscan II's, Goldenscan III's and Varilite VL5's simultaneously and has proven to be very user friendly and quick to program in an on the run situation. Following are a few of Active's' latest gigs.

**TAKE 40 TV:** Studio Centre Productions Melbourne. We are currently providing 4 x Goldenscan II Moving Lights every week along with our latest acquisition in control desks, the Scancommander.

**KATE CEBRANO AND FRIENDS:** ABC TV Melbourne, 8 Goldenscan II's controlled by de Scancommander, achtung!

**NATIONAL AUSTRALIA BANK AGM:** World Congress Centre Melbourne: 64 Par 64, 16 Raylights, 24 Pinspots. Controlled by Theatrelight 48/96. CREW: Grant Jennings, David Wright, Steve Cunningham

**ABC SPORTS AUSTRALIA AWARDS**  
Live to air awards show from the Grand Hyatt Ballroom Melbourne. EQUIPMENT: Colourset Par 64 & 5kW Scrollers, 2Kw & 5kW Fresnels with Theatrelight Desk. CREW: Grant Jennings. Call Active: (03) 819-6912.

**TROY BALANCE - Melbourne VIC -** have recently purchased a Yamaha PM-4000/48 Channel 56 Input Console, 2 x Yamaha MC 3210M Monitor Consoles, A Soundcraft "Spirit Live 4" 28 Channel Console and 30 x Yamaha PC-2602 Amplifiers to add to their Audio Production Department. Give Adrian 'Ada' a call on (03) 699-3844

**SHOWCORP PRODUCTION SERVICES - Nth. Ryde NSW -** have added a large quantity of Chain Motors, Concert Trussing and Rigging to their hire department. Call Graham Corkhill at Showcorp on (02) 878-1799 for hire rates and bookings.

**STAGING RENTALS:** "notes from the Netherworld": Prince Charles should be grateful to them. If David Grant's boys had built the stage out of our risers PROPERLY the little Cambodian assassin might not have tripped over the front edge of it. Or was he introducing a new Olympic sport, Reverse Stage Diving? Spectacular stuff!

And how about this one: "**How about a discount?**" Maybe...If you bring the gear back..It's only a week late. "**But can I have a discount?**" Is any of the gear damaged? "**Well, one of the risers is broken...in half. Actually, two are broken.**" It's great when you rent to a rock band and sweep your gear out of the truck after the tour!

But..... what about that discount?  
Call Staging Rentals on (02)519-6300 and remember "The customer is always wrong!"

**DAMIEN GERARD Sound Studios - Marshall Cullen** was called in as replacement engineer, (as John Henderson was touring elsewhere with Farnsy) and did YOTHU YINDI at the LAUNCESTON BASIN CONCERT, an annual two day 15,000+ crowd event, and thought the PA was worth a mention.

"The F.O.H. system was a fairly standard JBL Modular 6 x 18" w, 9 x Mid, 9 x Horn per side plus 4 old ACT Concert W's we unearthed and ran at ground level under the wings.

First problem was powering the ACT'S as being a 4Ω box they usually eat up the amps pretty fast. The latest AMCRON "MAC REFERENCE" amp was available which was apparently able to run into 2 OHMS, we were a little dubious but the unit was absolutely awesome and performed faultlessly for two 8 hour days barely metering above -15dB on input. Even sitting in the sun which was unavoidable didn't seem to faze the amp. Other amps used were AMCRON MACROTECH 2400'S FOR THE 18" W's, PERREAUX 8000c's, for all the Mids and AMCRON 1200's on Horns which all performed perfectly though none of those had to drive into less than 4 OHMS.

F.O.H. drive was also a little "new" being supplied by YAMAHA's latest DIGITAL EQUALISER and X-OVER. Marshall liked these.

Other new toys such as the SPX 990 and ALESIS ADATS were also present providing special FX and recording facilities respectively. House console was a YAMAHA PM1800 40 CHANNEL, monitors a new YAMAHA MC 32/10 and a SOUNDCRAFT DELTA 32 fed the ADATS from an active split".

The production was supplied by **HAMMER AUDIO of Launceston TAS.** Call Hammer Audio on (003)31-4122.

....

**Your material requested** (please) by March 15th, fax Caroline, (02) 876-5715, or write: PO Box 439, Epping NSW 2121.



# Brilliant Ideas



## Riga Compact Flood System

Singles/3 way/4 way

300/500 watt lamps

Designed for use with colour filters, colour frame included

Brackets and cables supplied. Ready to go.

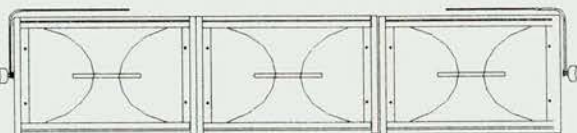

Only 750 mm

**Singles \$140.00\***

**3 ways \$320.00\***

**4 ways \$460.00\***

Prices include lamps



## DM1200 Club Mixer

Features 10 x Music/Line Inputs

2 x Master Faders

2 x Mic Inputs

- DJ Mic with auto voice over

Separate Music/Mic Buss Master

Cross Fader

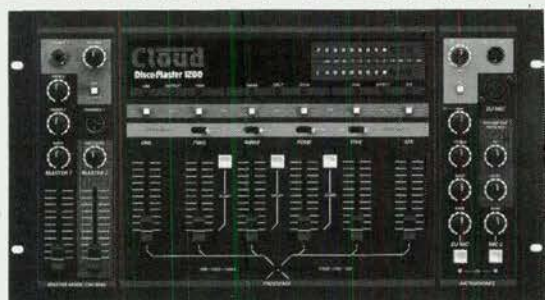

**Great value, only \$1425.00\***

## Le Maître

## Showmist Smoke Machine

The definitive theatrical and entertainment smoke machine.

Remote control (2 wire) features  
output volume control  
output timer control  
output interval control

Its quiet and economical with a 2.5 litre fluid bottle.

Inexpensive & new GENESIS technology heat exchange



**Always in stock \$1295.00\***

## NEW Pyrotechnics

Ice Fountain (Small & Large)

Aladdin Smokes

Silver Jets - Reduced Height

Robotics

Mini Gerb - Long Duration

Stockists of:

\* All prices exclude sales tax

*Dynalite*

**OPTIKINETICS**

**THEATRELIGHT**

**CELCO**

# LIGHT MOVES

631 Parramatta Rd Leichhardt NSW 2040  
Phone 02 560 0000 Country 008 807 805 Fax 02 568 2335

**TECHNOLOGIES**

Write in Reader Service number: 163

*Touring can provide the un-expected, but when it's lighting systems hard wired with dimmers in cardboard boxes, you start to wonder WHY you are there! Catriona Forcer talks to Mac Mosier*



## Bryan Adams' Asian Dramas

Genial lighting director Mac Mosier is doing it tough with Bryan Adams on the 'So Far So Good' tour, his board blew up in Perth on the first day. CLS in Melbourne were the nearest stockists of a Celco Gold

"I got the replacement console at 5pm before the first show here. Last time we were in Manilla Pat Brennan from LSD made up these adaptors from 37 pin socapex down to 24 pin D connector which is what they use. We used a different lighting company there this year so we got the connectors to give to them to use. While we were focusing suddenly the whole lighting system came up and smoke started coming out of the console. We made it through Manilla but when we got to Perth and plugged the power in, smoke started coming out again. After a month through Asia we were looking forward to dealing with real lighting companies and then my board blows up! It's been a relief though in the fact that we've had a really good crew here supplied by Jands."

The Bryan Adams tour started the day after Christmas at Jakarta and then continued for a month around the Pacific Rim.

"It's not really a tour in so much as Bryan always seems to be on the road," said Mac. "The lighting system we had in the Pacific Rim was a version of the lighting system we had last year when we came over here. All that was was four straight trusses with 72 Pars on three and 80 ACLs on the other. That's a large system to take

through there and it always took them a day to set things up so we couldn't do back to backs. Even then I was working 16 hours a day. I bought my own essentials with me - my own console, Colourmags and intercom - to go through that market and the rest of the gear came from local companies. Fortunately I had Pat Brennan with me from LSD and there were a few shows where at 6.30pm there was Fat sitting in a pile of dimmers soldering things to try make the show happen."

The local hire companies were an experience Mac will never forget although he said they always eager to please. Several bands have been along this route recently and the production companies appear to be trying hard to accommodate them.

"We were the first concert Bombay had had for three years and they said everything was OK," said Mac. "They had all the lamps and they were flying the gel in especially for us for London as well as a DMX to analogue converter as my desk will go either way. So we get there and it's all single hung Par cans with like zip wire going up to it that's hard wired in. The dimmer racks weren't in racks but sitting individually on boxes everywhere. At 3am the guy arrived from London bringing gel samples instead of gel so we just had this swatch book! That wasn't quite going to cover 320 Pars. I don't know where they got it from but they ended up getting gel at 3am, they must have gone to every

night club in India. The show had 33,000 punters and the tickets cost \$3. They try really hard and in the end the shows seem to come off.

We flew the lighting system into Vietnam from Singapore so the equipment was fine but I had four spot operators who had never seen a spotlight before. A lot of these places you go to they say they understand English but I found it best to have a training session in the afternoon. I ran through everything with these guys and they did pretty good. But when the show started they were in such awe at seeing a rock concert they sat there and watched the show instead! Lighting crew had to run up and take their places. We were the first concert the kids there had ever seen and they went wild."

The band and crew stayed in the hotel that used to be Allied Headquarters during the war and Mac was amused to discover that his bathroom had a two way mirror in the door. Throughout these countries all the band and crew got the usual tummy upsets and bugs despite numerous shots before leaving the USA.

Mac was surprised to find that a lot of these places had digital dimmers so being able to use the softswitch in the Celco and patch the dimmers to his channels was a life saver for him.

"There were a few places that had analogue dimmers but they were good enough to have everything close to being right," said Mac. "There wasn't one place where everything was perfect.

Bangkok was pretty close as was Taipei and Hong Kong. In Manilla they used inhouse dimmers and there I was, at 7pm before the show, with a flashlight pointing it into the Par cans to focus the lights because I didn't have any control over anything at that time. It's been very interesting going over there."

Whilst there Mac learnt that the Australian dates had completely sold out so the management decided they wanted a better looking show to put on as Australia is such a big market for Bryan. It had been planned to use the same lighting system as in the Pacific but, as it was basically the same as last years Australian concerts, a new design was wanted.

"As we're going on to Japan, South Africa and Europe, I needed to design something that would be easy to take from place to place," explained Mac. "Soft goods were the easiest thing to come up with. Originally the backdrop was supposed to be like a two tone grey and the columns were grey and lavender as were the borders. The lavender was supposed to match the colour on our passes so we sent a pass over to Tate Towers on the east coast of America. This was when they had the worst snow storms in 100 years and LA, where they sent the stuff to be painted, had the earthquake. So by the time we got them it wasn't lavender, it was deep purple. Needless to say Bryan couldn't stand it so we went to black." •

# LIVE

## The night was dark...

"Son Et Lumiere." Taken directly from the background blurb you learn that these two words founded their union sometime in the fifties among the grand castles of the Loire valley. Sound and light brought together to amplify and invigorate the stories of antiquity, to invoke images of events and people long past.

Today we present the latest offering in this art form 'Limestone, Iron, Time..' Set in the old Fremantle goal, a setting well suited to the telling of tales.

Our first approach to involvement in this production was through Mr Damien Hansen, Lighting designer and sometimes theatrical luminary in and around Perth. His curiosity, wetted through tales of the Goldenscan 3, became a raging torrent of enthusiasm after the mysteries of the fifth dimension were demonstrated to him.

Meanwhile, somewhere in a cell

Ron Sims, Sound designer, and his assistant Jacqui Purvis were busily collecting sounds on DAT tape for the soundscape.

David Deane-Spread, sound effects assistant and Executive producer has been the man responsible for the idea growing from conception sometime in 1991 to fully fledged production February 7th - 14th 1994. And quite some production it is.

At its core lies the eight track digital recording containing all the narrative, sound effects and score. Each of the eight tracks is routed through the big DDA foldback desk to its own send and Meyer MSL box, two stacks of UWA subs filling in the grunt. Sound production was overseen by Edo Brands while nice Guy Smith from Audex huddled over the knobs on those cold, windy nights.

Lets consider the lumiere.

Given a canvas as physically big as this you need to employ some

real power. The main surface to be lit was four storeys tall and some 80m from end to end. Primary washes for illumination were provided by the Par64s deployed on the deck with occasional specials. Interiors of the cells were lit by 300w linear QI lamps- six or seven to a circuit for the entire 86 cells, inside the chapel a series of 1k fresnels pumped out through the windows. Scattered around was an assortment of duets and 64s for those special moments. Feeding this little family were a mixture of Lightworks concert racks and Jands 12ch Digital racks, 96 dimmers in total.

Sitting up in tower next to Damien was 'Meaty' Brian Anslow our man at the Scan commander, who ran 12 Goldenscan 3 1200HMI as well as the 96 ch of

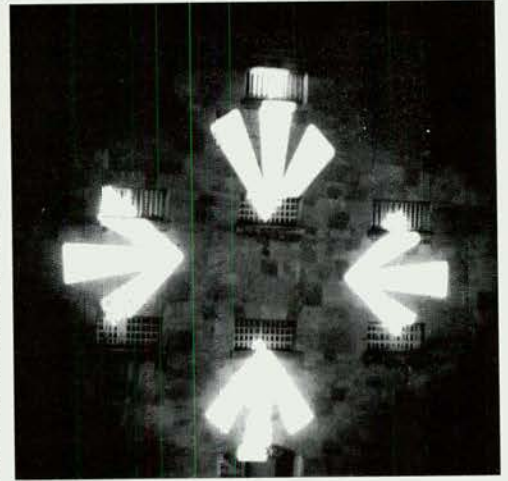

generic lighting.

Finally an instrument that makes too few appearances publicly, here at least, a PANI projector with assorted slides and lenses.

Special thanks go out to Sam and Shelley from Lightworks, Gillian for publicity up and beyond the call of duty and to the SAS. We also use and recommend Howard and Sons pyrotechnics for putting a little Australian sparkle in our lives.

□ ANDREW CHAMBERS

Designed for our most difficult customer, Jands Production Services.

They wanted everything: high power, high dynamic headroom, high quality, reliability, light weight...

We delivered.

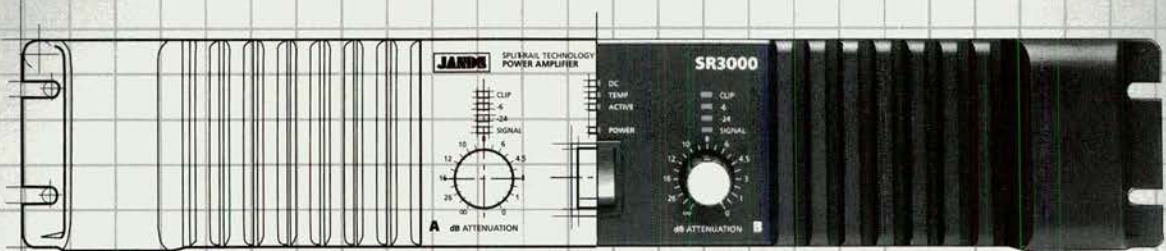

# SR3000/SR1500

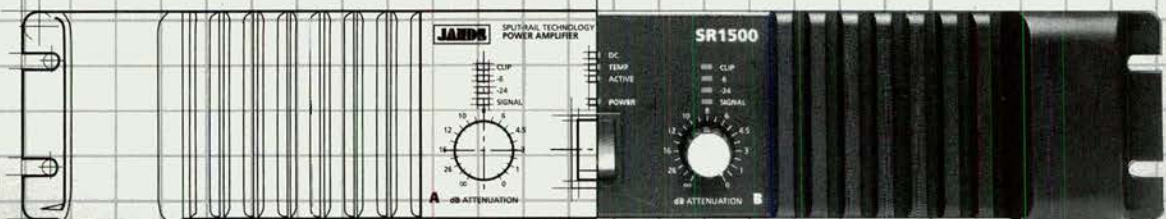

- 2 x 810W RMS/4Ω (SR3000)
- Up to 3 dB Headroom
- Rugged Construction
- Designed for touring Use
- 2 x 410W RMS/4Ω (SR1500)
- Full Protection
- Proven Reliability
- 2 Year Warranty

Jands Electronics Pty Ltd (ACN 001 187 837) 578 Princes Highway, St Peters, NSW 2044 Phone: (02) 516 3622 Fax: (02) 517 1045

Write in Reader Service number: 116



# Phantom Of The Opera

36 motors fired by computer make the visual trickery work - and it's all cunningly engineered.

Julius Grafton reports on theatre's most ambitious show yet .....

"Remove all loose objects from your pockets first" says Cameron Mackintosh Mechanical Manager Richard Martin as we step with trepidation out onto the Theatre Royal grid, which sits at a nose-bleedingly high altitude of 59' above the stage. I can feel vertigo coming on, really I can. "It's safe", offers R.M. as we now call him, a necessary shortening of name because his cohort is also a Richard - Richard Pacholski, the Electrical Manager, known around as "R2".

This is theatre at its zenith, the magic and trickery that holds audiences in splendour is unravelled for us on a technical inspection of the Sydney home of Phantom Of The Opera. A maze of space to stage left, stage right, above and beneath, forms a three dimensional labyrinth of electrical, mechanical, electronic, engineering and software driven devices in caves, tended to by a small army of electricians crew, mechanists and sound techs, working alongside wig technicians, make up and prosthetics experts, wardrobe engineers, and assorted stage hands, properties people, production assistants, stage managers, and .. and ...

When Phantom first opened at the Princes Theatre in Melbourne the official line was that Sydney's Theatre Royal was too small to house the show. It still is - kind of - but the Melbourne run was so strong that the producers had some leverage with the Theatre Royal's owners, the Lend Lease corporation, who committed some serious Cap-Ex (that's Capital Expenditure to you) and basically gutted the theatre to house a slightly redesigned Phantom.

The process started long before the show moved up the Hume Highway in 20 semi's. "Before Aspects of Love they spent 12 weeks in here", says RM, and the work entailed ripping out lighting bridges, and replacing a lot of steel.

Then eight weeks before Phantom moved from Melbourne the interior was totally refurbished, stage rebuilt and an old VIP room at the rear of the stalls ripped out, creating a sound mixing position. The only thing not touched were the seats and the carpets. It's

hard to explain the scope of the work, you need to remember the old Theatre Royal to see what's been done to house Phantom.

Take the stage floor, for example. A false floor was built on top of the existing one, with 200mm clearance. This allows for operation of some trickery that's obvious when seeing the production, like the candles that shoot up through the floor, and carts that scoot out from the wings. The candles are a mechanical marvel, telescopic and driven by motors and

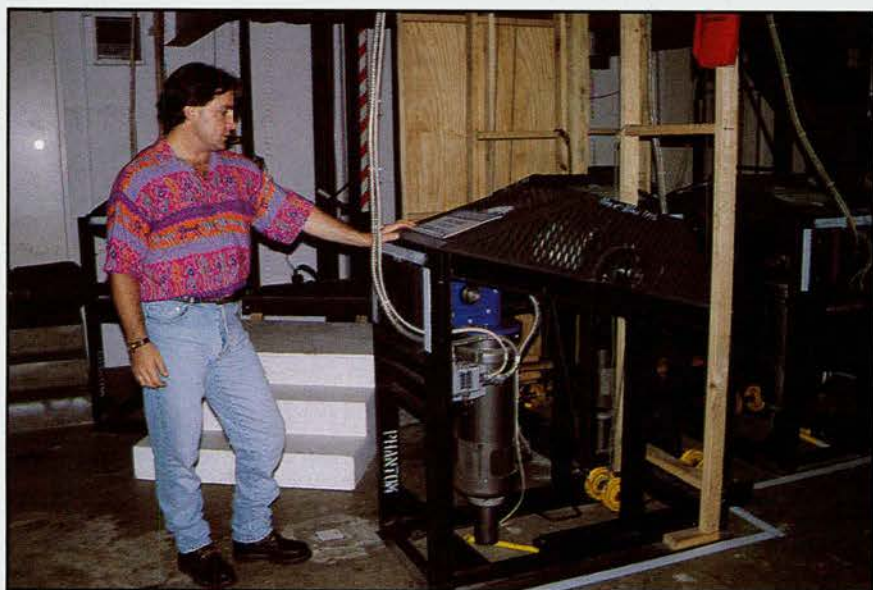

*Mechanical Manager Richard Martin with a motor in the basement. This one controls the candelabra tracks that scoot on and off stage.*

flexible shafts, while the Candelabra carts plug into slots cut in the false floor, and draw power through customised 'quick connect' plugs. This enables the scene shown at the start of this story, set and working in fast order.

### FLYING.

Part of the re-furb at the Royal includes a new counterweight system, now a double purchase system, meaning the rope travels twice as far, but the actual system is half the height and sits higher so floor space at stage level is created - in this case 1400mm extra wing space. The double purchase system needs double counter weighting, so a half tonne load needs a tonne of counterweight. Despite this, two mechanists can get this kind of load moving, and stop it again! Mechanists are wonderful creatures, but there are precious few women working the ropes. *(If we can find one, we'd like to introduce you to her via a story)*

If you've seen Phantom you'll know the show has a lot of flown elements, especially the giant Chandelier that is seemingly wrecked when it falls from the auditorium roof. This is achieved with two electrical hoists, one to allow a controlled decent, the other to take over at a predetermined height and drag the Chandelier upstage while 'collapsing' it.

Flying in the theatre is becoming more automated due to the advances in control that the digital era has offered, Phantom uses a computerised system developed by Bytecraft in Melbourne. This has now evolved into a commercially available system called the 'STATE' system, operated from a console by one person, and capable of running well over 100 separate motors. The Phantom system is affectionately regarded as the 'Belmont' version says RM, because it is an early version. Older Aussies into cars will recognise the analogy as meaning a current version of the State system is more like a Holden Statesman. The Belmont was the 'no frills' Holden of our youth.

The other end of the system comprises motor control racks that feed DC on-demand to the motors, and decode information from the limits and counters so the system knows the exact position of any load. The counters read 10 counts per millimetre of travel, which is more accurate than anything at Connections!

Phantom has a bunch of flown elements, including the main truss which, with curtains and cloth on board, weighs 1300kg. While this could be flown manually, it'd need 2600kg of counterweight, and six mech's to get it going. "It's not a case of doing away with labour, if someone caught a hand in a pulley - the show would stop. Here instead we have a motor that cost about ten grand." says RM.

Motors pull steel wires whereas conventional flying systems use ropes, so specific head blocks for wires were needed, because wires eat through the normal cast alloy rope pulleys. Automated flying systems are becoming common on new and refurbished stages every-

where, but are still most commonly used alongside a manual - or 'rope' - system.

The Adelaide Festival Trust built the mechanical and scenic elements of the show for Cameron Mackintosh, John Mignone is the Mechanical Services Dept. head there, and he liaised with engineering consultants Kinghills who certified everything after doing the numbers.

### CHANDELIER.

The main motor flying this monster is overrated to buggery at 40 horse power, and has a heavy reduction gearbox - ie: 40:1. The gearbox alone is capable of arresting the load if the motor stops turning, through regenerative braking.

If something goes awry, the motor will stop dead, and the 500kg Chandelier will stop too, hanging on overrated steel lines. When the power to motor is cut, two park brakes cut in. The rig is engineered with limits, counters and enough safety considerations such that you feel inadequate standing beside it- unless maybe you are a really well engineered human, like Arnold Terminator.

In the production the Chandelier does the great fall and is wrecked. In reality the thing cost more than my life is worth, and also has in excess of 17,000 pseudo glass beads attached. It is recycled daily, so the trashing effect is another automated illusion.

*Electrics manager Richard Pacholski with one of four really great dry ice foggers under the floor*

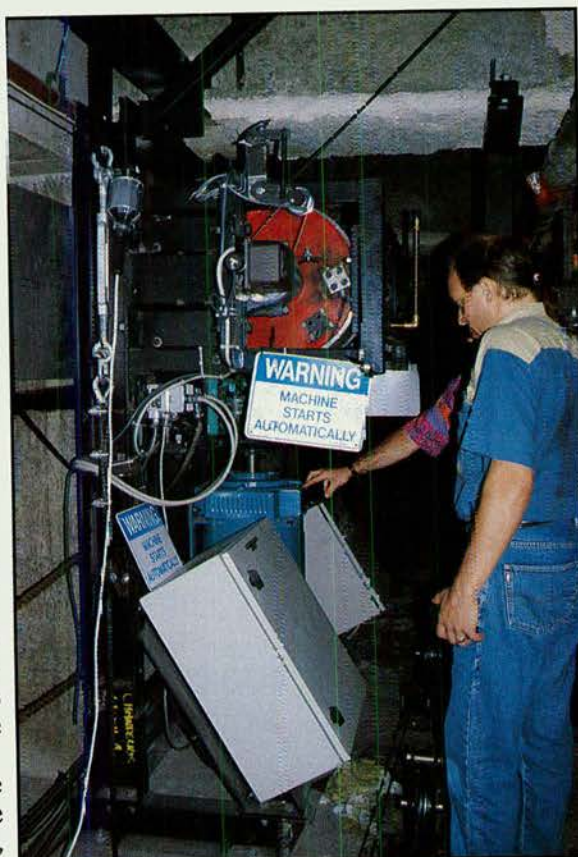

*One of two State flying system consoles, with video monitors to check every step of every cue*

Importer's Clearance of New and  
Demo Stock  
**UNRESERVED**

**MGS TURNERS AUCTION**  
OVER \$1/2 MILLION OF EQUIPMENT



**22 March (Tuesday) 1994 - 10.00 am**  
**13-15 Bridge Street, RYDALMERE**

**Under instructions from a major importer, due to a recent merger  
and the re-fit of three nightclubs.**

**LIGHTING FOR DISCO, THEATRE, BANDS**

**VIDEOWALL AND VIDEO EQUIPMENT**

**AUDIO - MIXERS, AMPS, SPEAKERS, CD PLAYERS**

**MOVING LIGHTS - ROBOSCANS, GOLDEN SCANS**

**LIGHTING**

**LIGHTING EFFECTS** - 50 effects and centrepieces from Coemar, Clay Paky, Lampo, Satel, Martin, Griven, ADJ, Geni, including Robozaps, Ministars, Moonflowers, Mantras, Crazy Moon, Devil Moon, Wildstar, Quattros, Astroraggi, Microstars, Derby, Stormtrouper, Astuto, Forte, etc,etc.

**INTELLIGENT LIGHTS** - Clay Paky Superscans (x 4) and Goldenscan 2s (x 4), Miniscans (x 2), Tigerscan MRG, Martin Roboscans (4 x PRO218s, 6 x 805s, 1200 MSR, 4 x PRO1220)

**THEATRICAL FITTINGS** from CCT, 1000 Watt, 650 Watt, etc. Par 36, Par 56, Par 64, etc

**SMOKE MACHINES** - JEM ZR20, Le Maitre Powermist, ZR41D

**STROBES** - Optikinetics, Geni, Alien **TRUSS** - Lightspan, Quadretti

**CHASERS** - 4, 8, 12, 108, Geni, Zero 88, Ice, Pulsar

**DIMMERS AND DESKS** - Dynalite, Zero 88, Jands ESP48, Stage 12, Sigma and Delta Packs

**FAIRYLIGHTS** - Budlight, Ciplight 1600m and transformers.

**AUDIO**

**MIXERS** - Including Tascam, LEM DM81s, Orion **TURNTABLES** - 6 x Technics SL1200 Turntables

**CASSETTE DECKS, AMPLIFIERS, SPEAKERS**

**VIDEO**

**VIDEOWALLS** - Complete 4 x 4, 28" Philips with Smart Wall controller 6 x videowall monitors

**PROJECTION SCREENS** - Various screens rear projected flat curved daylight

**LASER DISC PLAYERS, VCRS, 5" MONITORS, HYBRID 9 CONTROLLER, VIDEO 8 CAMERAS**

**SPARE PARTS**

Huge quantity of spare parts for Coemar, LEM, Zero 88, Lampo, etc

**MISCELLANEOUS**

Pinspots, fog juice, scanners, roadcases, lamps, neon, accessories, etc, etc

**OFFICE EQUIPMENT**

Mobile phones, office desks, fax machine, photocopier, partitioning, chairs, filing cabinets, plan file, computers, Macintosh, PC, pedestals, etc, etc

*Plus much more yet to be catalogued*

---

**AUCTIONEERS NOTE - A RARE OPPORTUNITY TO PURCHASE NEW AND  
NEAR NEW CURRENT STOCK AT UNRESERVED AUCTION**

---

**Inspection - Monday, 21 March 9.00 am to 9.00 pm and Tuesday, 22 March 9.00 am to 10.00 am**

**TERMS - Payment by cash or bank cheque**

**CONTACT SHOW TECHNOLOGY AUSTRALIA DIRECT ON 02 898 1111 or 1800 646 666**

**MGS Turners**  
**34 Morley Avenue, Rosebery**  
*Member of the Auctioneers & Valuers Association of Australia*

## Phantom (continued)

The boffins behind Phantom dreamed up a two motor system, the main motor raises and lowers to a point where a second motor takes over. Its wires are hung on a double purchase, fixed off to the auditorium ceiling, which come down to the Chandelier, through a pulley, and off to the motor. The Chandelier is in four sections, so when the first motor lets go it concertinas, the second motor is then pulling it upstage where two stagehands grab it to prevent it sliding back into the orchestra pit.

### THE BIG JUMP.

The audience love this one, the high fall into the lake, which is in actual fact a sea of low lying dry ice. The floor has a hatch cut into it, which is opened up. In the basement is a control room with motors, and dry ice foggers. In this room is also a stunt mattress, onto which the actor falls.

So picture this - there you are, 5 metres over the stage, preparing to fling yourself into space. You must have confidence that the hatch is actually OPEN - because you can't see it through the dry ice fog! However the crew have fixed this potential actor wrecking situation by fixing Snake Light around the mattress. So the actor has a visual cue, and doesn't jump unless the snakelights on the landing deck are turned on!

### LEARN AS YOU GO.

R.M. and R.2. think they can further refine the mechanical and electrical setup for Phantom, which will without too much doubt tour beyond the Sydney season. The problem now is that every position of every motor needs to be re-plotted, because cable lengths are of course different in a new theatre. Bytcraft may have this one sorted out, but the Phantom production policy is not to upgrade software. "If it isn't broken, don't fix it" is the credo, which we understand well.

Once the season in Sydney started, continual tweaks were needed because cables stretched and pulleys wore in, so the millimetre count would change. This was all expected, and presents no problem.

### REDUNDANCY.

You always have backup when dealing with technology, at Phantom it extends to manual crank handles for the motors, through to a second State console which is run alongside the first. They are separated into deck and flying roles, but both have the same software and cue files loaded, so if one should malfunction the other could run the whole show.

Bear in mind major concert sound consoles have dual power supplies, while Vari\*Lite tours always have a second Artisan control console setup- it's not an admission on the part of the manufacturers that the technology WILL fail, rather that

it CAN, even if it doesn't.

The Bytcraft motor control racks also have dual componentry, in effect they are 'stereo', and can be switched over or even driven manually with 'UP' and 'DOWN' override buttons. Unique to Phantom is the use of 'Deadman' (or dead-Person) buttons, "the idea is the operator must sit with the cue, not punch it on and do something else" said R2. "If they are really busy there is a footswitch too", said R.M.

A bank of video monitors allows scrutiny of each motorised load as it does it thing, in some cases from multiple angles. In the motor positions are various spare motors, crank handles and parts, despite a virtually nil failure rate. "Working for a couple of underrated minutes the motors should last about 150 years", said R.M. •

The dry ice fog machines (pictured previous page) are 44 gallon drums, the water is heated by 3 phase heaters, then pumped UP over the 20kg of dry ice in a top chamber. The pump is fired from the lighting desk, the fan runs on a channel fader so speed is controlled and thus dry ice fog flow is on demand and remote fired. Neat!

### Mechanical/Electrics crew

Technical Director: **Mort Clark**  
Mechanical Manager: **Richard Martin**  
Electrical Manager: **Richard Pacholski**  
Technical Co-ordinator: **Danny Yezerki**  
Assistant to Technical Director: **Suzie Clark**  
Mechanical Engineer: **John Mignone**  
Head Mechanist: **Gary Rappel**  
Head Flyman: **Mal Pierson**  
Head Electrics: **Paul Rigby**  
Electrics: **Ed Cyerman**  
Electrics: **Ian Blackburn**  
Production Stage Manager: **Anneke Harrison**  
Head of Properties: **Bernie Fitzgerald**

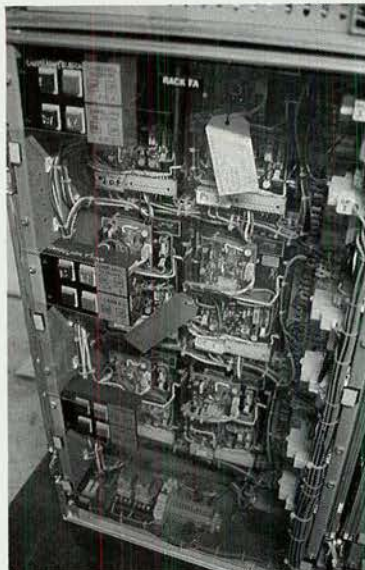

Rack for motor control purposes

## dmx Commander

SHOWCRAFT



### RIGGERS CONTROL

Plugs straight into the dimmers and you get full lighting control right there on stage!

### BACKUP CONTROLLER

You won't be left in the dark if the main desk goes down.

### DMX TESTER

A quick checker for technicians and hire companies.

**All for only \$395!**

Available from  
Lightmoves, Sydney 560 0000  
Lightmoves, Melbourne 819 4566  
Coemar Desisti, Melbourne 467 8666  
East Coast, Brisbane 252 9583  
Theatrecrefts, Perth 227 7015  
Showcraft, Sydney 698 3009

Proudly Made in Australia by SHOWCRAFT

Write in Reader Service number: 102

### LA Audio 4C

- 4 Compressor's
- 4 Limiter's
- 4 De-esser's
- 4 Variable filters
- Any combination
- Multi channel
- Split band
- Fully balanced
- Less than \$1295

### LA Audio 4X4

- 2 Compressors
- 2 Gates
- 2 Assignable dual filters
- 2 De-essers
- Any combination
- Multi channel
- Less than \$1039

**MG**  
Microtech Gefell



**LA**  
AUDIO

Southbank Trading

PO Box 6068  
St Kilda Road VIC 3004  
TEL: (03) 699 7809  
FAX: (03) 696 5691

# STING: 'TEN SUMMONER'S TALES' TOUR



**You can do a lot with a few drapes and a Kabuki system, as Cat Forcer discovers....**

The current Sting tour has been on the road since January 1993 and continues until the end of March with a tour of South America.

"We've just done the Pacific countries like Jakarta and the Philippines and we'll use the same simplified rig for South America," said Nick Sholem, lighting designer. "They just don't have the technology at these places so I simplify the design and just use a local rig. We'll have a slightly messed around with rig when we go to South America in fact we're still putting that together as information is so slow coming from there."

The biggest problem Nick had through the Pacific rim was the fact that he was using either a Celco Gold or a Celco Major, both analogue desks, and nearly all the dimmers he encountered were digital. In Manila they did not even have plugs but just bare wire twisted together so the crew were banned from various areas for obvious safety reasons.

The Australian show was a revamped version of the 1993 design, the main change being the replacement of several Pars with Colourfaders on them by VL5s. This makes the total number of VL5s twenty-seven and there are also thirteen high-resolution Intellabeams. In the air are eight ACL Moles with LSD Colourmags on them, four DWE1s for the audience and another five Molemag DWE bulbs for the kabuki drops. The actual number of Par cans is only thirty in the air with fourteen on the floor.

"The best thing about the whole thing is that I'm running it through the Wholehog

desk," said Nick. "Absolutely everything goes through it - smoke, UV, every single instrument and we trigger the kabuki through it as well. Rich Lochlin from Upstaging, Chicago, is my crew chief who travels the world with me and he actually triggers that. Of course we've got the infamous Nicky Koumos from Jands as crew chief here in Australia so I'm working with two crew chiefs. It's great because I don't have to come in very often! I just stroll in for the show and leave! Actually I focus the Intellabeams and Vari\*lites on the Hog but I don't really start until 4pm."

The rig is fairly quick to put up and dismantle - roughly two and a half hours. On previous shows Nick has been known for his work with Vari\*lites but he decided to use Intellabeams, for the first time, on this tour because they are 'cheap and cheerful'. Although Nick still thinks Vari\*lites are great the extra operator, extra tech and extra board space decided it.

"I needed something to wiggle and so I used the Intellabeams which have been fine," he said. "Then I slowly added the VL5s, as soon as they became available for DMX, and as soon as the VL6 comes out I'll use them with the Wholehog. The VL6 will be a Profile and then I'll have the best of all worlds. The VL5s are absolutely wonderful as they never go wrong. I've never had a problem with having a Vari\*lite operator next to me but with a Wholehog you have total control over the show. You get the occasional problem with the Intellabeams but nothing major. Because it's DMX, it's a whole

*(continues page 34)*

**A 4 piece band, Clair Bros engineer and a Jands S4 system. What did our 'failed sound engineer' editor think?**

This Sting tour is audio purity from a 4 piece band, stripped back to basics and sounding immaculate. 48 Clair brothers S4 speaker cabinets flown 24 each side, with a pair down on the deck made for great sound. The system used in Australia came from Jands and was practically identical as the one I heard Tina Turner through in the same arena.

This time around the sound engineer made all the difference in the world, Michael Keating mixed Sting on a Yamaha PM4000 48 channel console, and produced the goods from the opening bar of the very first number.

"Problems? The only problems I've had is using shit gear through Asia" he barked. A purposeful kind of guy, Michael strode into the gig 15 minutes before the support act finished, casual in shorts and thongs. Sting toured a circuit I suspect Frontier Touring are establishing though the North, playing Manila, Singapore, Hong Kong and such places. "The only place I got a decent system was Singapore", Michael said, referring to the Jands/Clair Brothers system that is based there.

"It's a challenge keeping the sibilance out of sting's voice, I use a DBX 902 de-esser sidechained to a Summit limiter", Michael says, explaining the four piece band eats up a total of 44 input channels.

The monitor engineer is C. J. Patterson, himself a 20 year Clair guy like Michael. In fact it is the monitor board that gave Michael his big break, he was drafted by Clair to handle drum monitors on a Bruce Springsteen tour after the regular got sick. "I thought I'd get the sack, I hadn't done it before. Then I survived because I got the drummer rockin', no one had made the guy happy before!" This didn't escape sound engineer Bruce Jackson, who put Michael forward when he finally took leave from his long standing engagement at FOH for the Bruce.

The Sting Monitor system from Jands was driven by a Midas XL-3 console, the only dual purpose mixer truly at home in a concert environment. Clair Brothers AM12 wedges are a low profile JBL loaded speaker cabinet, but it's the electronics for the system that are really cool. A sign of things to come.

TC Electronics programmable third octave equalisers are used, the advantage being the engineer can walk out to the microphone position WITH the master control head and make adjustments there and then. This negates the need to stand at the mic and bark directions to an assistant at the Equalisers - like "2k down 2dB, 4k up 2dB", etc.

I said: "Great sound!" **-Julius Grafton.**

**STING AUDIO PICTORIAL**



Michael Keating & the Yamaha PM-4000 front-of-house console



Here are the TC Electronics programmable 3rd octave equalisers



.... and here is the TC Electronics third octave equaliser control head, which you can take on-stage to tune your system with

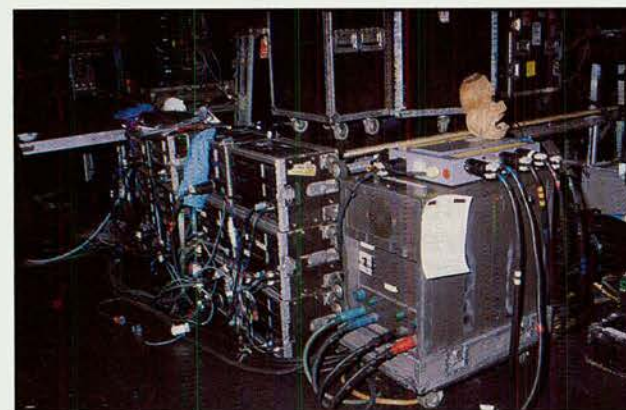

Here is a 'big pig' stepdown transformer to power the 110v Carver power amps in the Jands/Clair Bros. foldback system, shown also.

**AKG**  
ACOUSTICS



MAKE YOUR PRESENCE KNOWN.

TRI-POWER SERIES



Hear and feel the power of Tri-Power at select musical instrument dealers near you. Tri-Power vocal and instrument mics. They are what you have been waiting for. Live performance microphones from AKG



AWA Distribution  
Postal Locked Bag No. 18,  
Granville, NSW 2142

Unit 1, 175-179 James Ruse  
Drive, Rosehill NSW 2142

Toll Free 008 252-391



Nick St.olem (left), Rich Lochlin and helper

different way of treating things compared to the old analogue system so you have to get your head around that. Nicky Koumos has been landed with that for the first time but once he saw what was going on, he was fine. It's the way we're going, everything is going to go DMX. I've worked with Nicky on shows over here since 1984 and he damn well deserves a mention as he's absolutely wonderful.

The Wholehog has a massive amount of memory so you're not restricted by the amount of channels you can use - it has 6000. You can write up any fixture, you just have to develop it on the rack. Some of them, like Intellibeam high resolution, are stock and already in there. You just tell it how many you've got and it figures out everything else for you. On a daily basis you just do the same as you would for any other board, you just update your focus positions and it tells every cue to go to that position. There's nothing restrictive about it at all and there are several different ways to operate it too. I've chosen a stack method where I've got the songs stacked so I go through each cue by just hitting one of the buttons and it rolls through to the next cue. I can alter the time from 0.1 seconds to 4 hours if I want to.

Unfortunately in Australia Nick could not get the LSD Cclourmags to go through the Wholehog because they could not get the information out of LSD to make it work so a separate board had to be run.

"The only drawback to the desk is that in the 90s we're just starting to run digital systems for the first time ever so the drawback is that we don't know the drawbacks!" said Rich Lochlin. "What problems we have we've never seen before. With analogue, if something broke

or blew up it turned off. If something blew up with this, it could turn on - how do you know?"

The only lighting equipment Nick had brought out to Australia was the Wholehog, two racks that go with it, the multicore and his own intercom system. The intercom system was important for the Pacific rim because even if the equipment there was 'crap' at least they would be able to communicate.

Nick has been working with Sting since the early Police days of 1980 and on this tour he was more involved with Sting on the design than ever before because of the kabuki drapes. The drapes are the main visual element to the show and obviously Nick did not want to spend thousands of pounds making a look that Sting might walk on stage and say he hates. Nick had some 5ft square versions made up which he presented to Sting at his house.

"It was fine except for one which he didn't like," said Nick. "We changed it but kept it the same if you know what I mean! He doesn't get involved in the lights as he's colour blind. He was talking to Bob Geldorf in Adelaide the other night and he said 'I leave it all to Nick, everybody says he's good so he must be. As the drapes are the main feature there's no wham bang lighting.'"

The kabuki system for the drapes was designed by Nick and built by Brilliant Stages of London, England. "The system is great and just never fails," said Nick. "There are individual motors on each drape - five in Australia but the system can accommodate seven - but because they have been manufactured so well they all go together. Most of the time when I drop them is in the blackout anyway but when I have to lose Hironemus Bosch, there's no way of doing it in a blackout as they run two songs together."

The kabuki is activated from the Wholehog which triggers a timer backstage which, in turn, sets off a four second pulse because the kabuki needs a permanent hold to get the motors to roll over and drop. The kabuki system is an 8ft frame - can go to 10ft - with three pipes in it and each pipe has double spikes so there are two drapes on each pipe. The drapes have brass eyelets which, when against the metal of the spikes, slide easily off. The motor sits inside the pipe so it can roll one way, then

the carpenters have switch boxes and they have to preset the next move before it is triggered via the Wholehog. On average it takes 2.5 seconds for the kabuki to go from normal to a drop position and a limit switch in the timer box ensures that the kabuki can't over roll.

The show starts with the five grey panels almost like a leaded window, produced by Dave Perry Productions of Birmingham, England, which are fairly mellow. The beauty is that the audience have seen them since they walked in the door, the support band have played against it and Sting has played against it for six numbers, when suddenly Sting goes into the Police songs and it's gone. In its place is a bright, multicoloured drape with some secret UV patterns hidden within it which are turned on for a couple of numbers. The result is two very different looks out of the one drape. Then that falls away and there is a two panel drape which is off-set on centre and stage right and depicts a Hironemus Bosch painting. His work is hell, fire and damnation stuff and is used for the song 'St. Augustine'. After that it's a completely black background for three numbers including the 'heavy metal' number of the show 'King Of Pain'.

"We just kind of rock out with the lights and use loads of smoke," said Nick. "We have a F100 upstage centre for smoke and that's the only time it's used. For the rest of the show we have a pair of crackers to do the building. When the blacks fall away there are full red curtains on which I can get some shapes happening. Then we go into the technically termed 'My Wives Knickers' look which consists of austrian swagged voile material. Sting saw the fabric and said it looked like something my wife Emily would wear for knickers (how did he know?)."

The austrian curtains stay for a couple of numbers and during the second song, fans at the bottom of the curtain are switched on so the fabric begins to ripple in an extremely effective manner. For the last song, the star curtain comes on behind and around the curtains and the lights shines through the fabric. On the last cue the curtains are released and flutter down to the stage. It really was a brilliant ending to the show which built up gradually to its grandiose finale. •



Incorporating MGA Bates Insurance Brokers

**"BEST INSURANCE BROKER"**

1991 & 1992 Australian  
Music Industry Awards

**(02) 957 3211**

CONTACT KEN KILLEN or IAN STACK  
Level 11, 118 Alfred St, Milsons Point, NSW 2061  
PO Box 1809, North Sydney, NSW 2059  
Ph: (02) 923 1066 or (02) 957 3211 Fax: (02) 929 4584

Insurance Specialists for

- MUSOS ■ RETAILERS ■ WHOLESALERS
- STUDIOS ■ TOURS ■ TRUCKS & CARS
- SOUND & LIGHTING
- REPAIRERS ■ EVENTS
- HOME & CONTENTS etc etc

WINNER 1993 INSURANCE BROKER OF THE YEAR  
National Insurance Brokers Association Award

# LENNY KRAVITZ

*Catriona Forcer braves the retro '70's for a dose of Lenny*

Sound engineer Tom Edmunds started his career at the tender age of sixteen when he began working for Janis Joplin's band 'The Full Tilt Boogie Band'. Based in Woodstock, New York, he continued to work for a variety of people like The Rolling Stones and, in particular, Todd Rundgren who he travelled on the road with as well as doing his studio work. Working as an independent engineer he mixed many bands including Meatloaf but continued touring too. For the past four years Tom has been with Lenny Kravitz.

The Australian tour used a Meyer system, supplied by Audio & Recording (Sydney), with eight MSL10s, 32 MSL3's, 20 sub-bass 650R2 cabinets and 20 DS-2's.

"It's a really pumping system," said Tom. "The first day was a bit rough but we've got it really tuned up now." Tom encountered some problems at the first show which was at Brisbane Entertainment Centre.

"I came in and I wasn't happy at all," he said. "It was a rehearsal day where we were going to sound check and Lenny wasn't happy either. We had to take the whole PA down and start all over again but we got what we wanted. Now, once everybody knows what you want, then they put it back that way. They had the sub bass flown in the air and sixteen DS2 cabinets which are low mid cabinets. I really don't like the way DS2s sound, they're very honky sounding and sort of bark at you. There was

no warmth. I put the sub bass back on the floor as I like the feeling of the sub bass on the floor, it makes your feet rattle. My concept is a great big stereo, that's how the system should sound. I like to feel like I'm in a huge studio and we're there now."

Audio & Recording chief Ian Richardson says the Kravitz entourage didn't ask for the system to be configured in any particular way, but after the misunderstanding was ironed out they were really happy. Tom admits he has to work hard to get Lenny comfortable with his vocal although apparently Lenny was extremely happy with the first performance in Sydney even thanking the monitor man - Harold Danker.

"I've bought my own front of house console and all my outboard with me from the States", said Tom. "I use a Gamble console which is totally discreet and has sixteen sub groups, eight stereo sub groups. It's a really warm

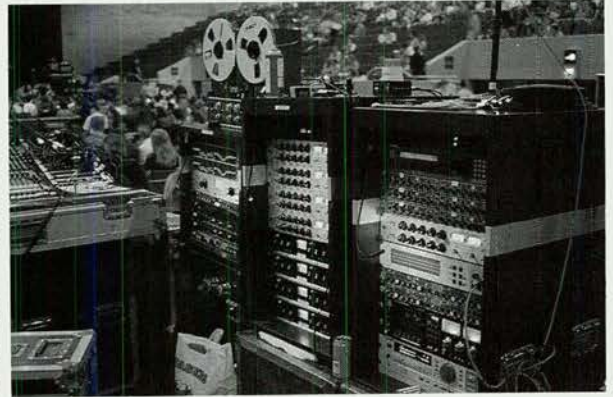

*Very analogue ... well, lots of valve effects anyway, like Summit valve levellers etc. Note tape deck ... what for?*

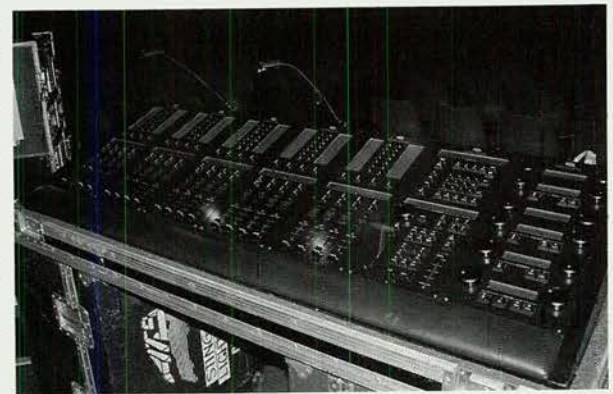

*Whole Hog lighting desk in the whole flesh! Small, and oh, so clever! Drives lights, Intellabeams & some Vari\*Lite's*

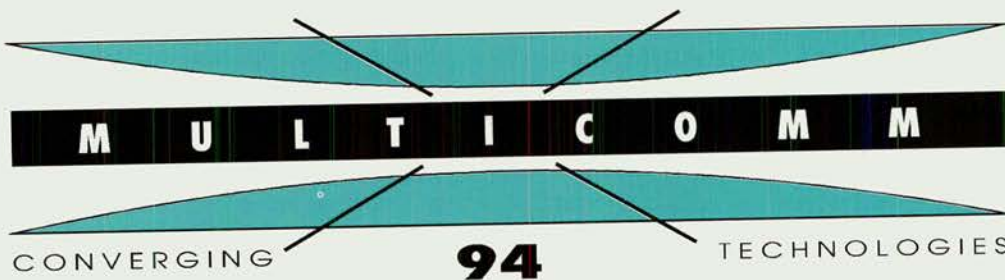

**Information**

**Communication**

**Presentation**

**Products and services demystified in a definitive technology exposition:**

- AV Presentation and Communication
- Multimedia
- Audioconferencing
- Videoconferencing
- Professional Audio
- Video Display Systems and Technology
- Control Systems
- CAD Modelling and Design Software
- Systems Integration

*Much more than an exhibition!*

**Includes Seminar Workshops aimed at the end user with sessions on hardware, software and system application.**

**Sydney Convention and Exhibition Centre Darling Harbour 3-5 May 1994  
Organizer RWV Seminars Phone (03) 882 8039 Fax (03) 882 1855**

## Kravitz (continued)

sounding desk, I'm really not into modern technology that much. I use a lot of tube limiters, tube EQ, 2 pre amps for Lennys voice. Lenny's really into all the vintage guitars and vintage sound. If you look at the stage it's old Marshalls, old tweed fender amps, a lot of microphones and hardly any synthesizers. The kind of synthesizer we do use is an old harp string ensemble so it's all vintage. It just sounds so much better to me. I see a lot of shows that I don't like just because the sound is too harsh for me."

With old equipment on stage such as the Yamaha pianos and Hammond B3 organs, several technicians are required to ensure they work properly every night as break downs do occur. Throughout the world tour, Tom has kept a technician with him - Ed Gonzales - who 'takes away all of his problems'.

"He's very consistent and from room to room we can get the show sounding very consistent which is rare," said Tom. "I've worked with lots of people over the years and often you're happy to get the sound OK but Ed knows what I want to hear and he knows how to get it. I walk in and it's always consistent. The Sydney Entertainment Centre is excellent and I was really happy with the sound there."

After the tour, Tom is going to be doing some studio work with Lenny who wants to try record with a band live in the studio.

**LIGHTING:** Lighting Designer John Pollak was trained in the art of stage craft and theatre in Los Angeles where he grew up. This led to a degree in technical theatre and consequently an early career in the theatre. This progressed to modern dance, an area he would like to return to. The transfer to the 'improvisational world of rock'n'roll' was easy for John although the gigs he got were not something he actually went out and pursued. They just seemed to 'happen' and he decided there was a living to be made there.

"It's been slow but steady with small incremental advances in my career," said John. "I don't try to do something that's far greater than I could ever scope or wouldn't benefit from me doing it. There's a large scale of possibilities I would love to do. The knowledge of theatre gives you a wide background of 'tricks' to call upon. It's important to know the whole idea of the play and presenting something to the public is a package of many different parameters. The same thing holds true with a rock show. You can lead the audience in a sort of symphony with a beginning, middle and an end."

John has worked a lot with jazz performers and bands such as Bob Dylan. John admits that lighting designers come and go all the time with Bob Dylan who he describes as 'not a visual person'.

"I didn't know Bob's reputation lighting wise before I arrived on the tour and then the hor-

ror stories came out," he laughed. "To tell you the truth, with a little bit of knowledge about keeping lights out of peoples eyes, he's not hard at all. Doing that tour broke a lot of stern habits and ideas that I had about how to approach a show."

With the band Missing Persons, John said it was the drummer who taught him how to cue lights off drums. "In rock'n'roll I would think that at least 50-70% of the cues that you take originate from the drums," he said. "The appreciation of his style led me to a higher plain in the way I process the idea of the cues. He had built a show out of his presentation so I thought maybe I should develop that even more."

John was asked to design Lenny's show by a management company that got fired two days later. Fortunately John stayed as the other management company knew him and he described himself as the least of their problems at the time. Based in England, John went to Meteorlites with his design of the circular pod which was originally Lenny's idea as he wanted to recreate the lighting effects from his video of 'Are You Going To Go My Way'.

"At first he wanted to take the refrigerator bulb machine on the road but the management told him to wake up!" said John. "He asked me to try recreate that look so I put 120 Par cans in a circle which he was happy about. It does serve the purpose as a representation of the video form in a large show and it's quite flexible."

By the time the European and American tours were over the system was extremely fine tuned resulting in no mistakes and consistency. Certain elements of the system have been bought to Australia but John admits there are not enough to make it cohesive, a mistake on his own part although there were financial restrictions.

The original pod was actually a decahedron with lamp bars fanned out to form equally spaced spokes within the pod. In Australia there were twenty bars of six, on trussing, that fanned out in a circle, each with two colourchangers. The colourchangers were placed at random around the shape. Interesting chases within this structure were produced throughout the show. Within the pod were four Intellabeams fitted with custom gobo wheels produced by Meteorlites. At various heights around the stage were twelve more Intellabeams. The Intellabeams and Colourchangers (although originally John had hoped to use Colourfaders here) were operated with a Wholehog desk.

"It's a great desk for technology and it's the kind of desk where the learning of it expands as you use it," he said. "There are certain facilities with it that can expand the horizons of

what an automatic board does. It's very versatile."

In the very centre of the pod was a 2.5kW HMI lamp to give a brilliant white shaft of light from the centre. Hanging from the back truss were five 4 cell cyc light creating a powerful light source. The generic lighting was controlled by John via an Avo QM500 180way which John describes as an old dinosaur and fitted perfectly with Lennys show.

Originally ATS had the contract to supply production for the tour but with the Jands takeover, the contract obviously went to them.



Sound engineer Tom Edmunds

John is shielded from the political side of companies, all he wants to know is 'does the gear work?'. If he had been told, John admits he would have done a few things differently although Jands have supplied everything he has requested.

"I haven't had too many problems although there are still a few things to work out," he said. "Being our second show, we did well and I'm happy with the advances. Things take time and the crew is very good."

"Lenny has the propensity to throw in songs to his repertoire," said John. "So we have to have a battery of backup looks. If we go into a look and it's not the right song, we know how to adjust it or go into the right song or even 'busk'. Lenny's music is easy to light as he has lots of different pieces of lots of different styles. There are a lot of obvious looks that need lighting and he has a lot of input in what he wants to see. I like input from the artist, he tries to convey to me what he wants to see and I try to recreate it. I build a show with a beginning, middle and an end. You want to bring the audience to a peak and I would say the best look of the show is the last cue."

John does not like to draw too much attention to the lighting which he believes is just part of the package. "In it's best form it should be subliminal to the audience," he told me. "There are times when it causes a reaction but it shouldn't be a distraction. It should be a compliment to what's going on because even in the highest forms of lighting for concerts, like Pink Floyd, it still is about music. It also seems to me that bands who play in minor keys get better lighting! The minor key is more evocative for lighting."

The tour has nearly been renamed the 'The Tour of the Catastrophe' as the original schedule had them arriving in LA just before the earthquake strikes, travelling to Hawaii where another earthquake occurred and then onto Sydney where the fires would have just struck. Fortunately the schedule changed but the crew are a bit nervous about their next destination which is Japan where the 'Big One' is said to be due soon! •

# Soundfirm thinks they're great too!

TASCAM would like to take this opportunity to congratulate Soundfirm on their purchase of eight TASCAM DA-88 Digital Recording Systems. To give them maximum effectiveness and flexibility, Soundfirm have configured their eight units as two 24-track and two 8-track set ups, spread over their Sydney and

Mebourne studios.

TASCAM, in conjunction with Audio Visual Designs, takes this opportunity to invite audio and video professionals interested in the State-of-the-Art Digital Recording Systems to attend a working demonstration of these

new systems in their working

environment, at the prestigious Sydney studios of

Soundfirm. Due to the interest likely to be generated in this special event, and limited numbers of places available, it is advisable that you book your place as soon as possible.

Call Audio Visual Designs on (02) 716 0211 for the next session

details. And see why Soundfirm

made DA-88 their choice.

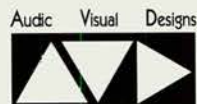

## TASCAM



TASCAM Australia Pty Ltd

Telephone: (03) 646 1733



## Review: Tascam DA-88 Digital 8 Track Recorder

By Bruce Waite & Dave Macken, Blind Lemon Pie



Here we go then, welcome to "DIGITAL EIGHT TRACK WARS". More technical, more expensive, more superlatives and much, much bigger than boring old "analog eight track wars". Now that the digital recorder marketplace is flying closer and closer to the ground, where there are many consumer dollars, the choices are increasing and the action is hotting up.

We recently received correspondence, via this publication, that expressed concern over the fact that there is more than one digital eight track on the market and we hadn't yet started to bitch over the different models and design approaches. Later in the year we are even considering stooping to a comparison test, but for now—just relax. The technology has never been better, let's enjoy it! So, for your reading pleasure we present Tascam's digital eight track warrior.... the DA-88.

Ye god's what a tiny instruction book, if you hate instruction books

you're going to love this. Twenty five pages front to back, it's hard to know whether to laugh or cry, as the technology advances the amount of instructions to be digested diminishes. Due in fact to this instruction books' size, or lack thereof, this article will actually only be half the normal text, printed twice. (Kidding!)

Apart from some strangely reminiscent phrases which are delivered in ye olde "broken Tascam English" the manual reads pretty well and should enable even first timers to get it going. What it does fail to mention though, is that the

machine ideally prefers running on "MP" (Metal Particle) Hi-8 tapes. The wholesaler, upon enquiry quite succinctly pointed out that anyone who knew what they were doing within the genre of R-DAT recording would know that MP tape is the standard preference for digital storage! Newcomers be warned, make sure you read the update sheet enclosed with the warranty card because the manual merely says "record on a standard Hi-8 tape". However, using ME series tapes apparently increases the likelihood of data problems.

*(continued on page 40)*

## EX-TRACK

With Greg Simmons

Here's the news... The King in Kogarah? Looks like Jeff Cripps, owner/operator at A# Sharp studios, is gonna be a busy boy for a while. Apart from his usual recording commitments, he's also playing drums in 'Elvis — The Musical'. Jeff's been busy recording CDs for Astral Taxi and Krazy Creatures, and is starting a 12 track Christian CD for John Ng. If Elvis is still alive, we know where he'll be recording (plenty of slap echo, Jeff). Call A# Sharp on (02) 553 8136.

• Hornibrook Audio Design & Maintenance, soon to be known as Brook Audio Design, has recently moved into a new workshop and office right next door to Airmotion Studios, in their St Peters warehouse. Mark Hornibrook has been working in close association with the funky Megaphon and Airmotion for quite some time now, so the new arrangement works perfectly. Call Mark on (02) 519 9220 and ask him for a test run of his awesome power amp.

• Foghorn Records are continually on the go, with a new release from stable inmates Once Upon A Time, simply titled 'God', to be released as a video single in February. (Watch for the world's first rubbish bin altar in the clip!) Meanwhile, the LA earthquakes (they're a natural phenomena, not a rockabilly/grunge band) are stopping Once Upon A Time's Jim Reece from returning to LA to shoot the video clip for his other band Driver. The album should be out soon and, yes, it's guaranteed to make the Earth move. The Drue Tyson Hoile album is due out in March, and features performances from Divinyl's Mark McEntee and Leonardo's Bride vocalist Abby Dobson. • Ancient



## WORKBENCH

With Howard Jones

### REPAIR OR REPLACE?

Some repairs have come through the workshop lately where the units involved were "of a certain age". EG: a Sony consumer grade cassette deck, about ten years old, and basically never serviced. The heads were heavily worn, and we suggested that the owner consider replacement heads. However, this was not his primary concern as he felt that he was still obtaining reasonable performance from the deck. What was annoying him was the tendency of the machine to stop after just a few moments of

running tape.

This model, in common with so many others, has a castellated wheel driven from the take-up hub. An infra-red transmitter and receiver are mounted on the edge of this wheel, such that the infra-red beam is periodically interrupted. So long as the tape shut-off circuit is receiving regular pulses from the receiver, power remains connected to the reel motor. If the wheel stops revolving, the shut-off disconnects

*(continues on page 40)*

### OLD NEVES NEVER DIE!

When Steve Bray of AR Audio Engineering mentioned to two people that he'd soon be getting an old Neve as a trade in on a newer console, he had no idea how far and how fast the word would spread. Within days he was receiving calls from right along the East coast of Australia, with people offering to buy it 'sight unseen'. The desk dates back to around 1975 and uses a combination of Neve 5305 and 5302 modules in a 32/4/2 configuration. Every channel features three band EQ with HF and LF shelving and peak/dip midrange (all sweepable), along with high and low pass filters and P&G faders.

For more information, call Steve 'The Neve' Bray on (02) 299 3666.

SEQUENCERS & SOUND MODULES EXPLAINED: Page 76

## STUDIO PROFILE

*Megaphon/AirMotion, Sydney.*

When approaching these studios, like many overseas, you tend to think you are about to enter the set of 'Escape from New York'. The surroundings are far from salubrious but the studios are well equipped, maintained, clean and comfortable.

Guy Dickerson and Shane Fahey are the masterminds and builders of both Megaphon Sound Recording and AirMotion Studios. Guy has been with the project for ten years and Shane for eight, and their combined knowledge has enabled them expansion on a scale that would cripple a small company having to buy expertise.

Guy is not only an engineer but also appears in the guise of a self-taught carpenter and has been physically, personally responsible for much of the construction, renovation and acoustic treatment on both studios, working alongside professional builders, Gordon Fraser and Bob Shearer on the major works.

Shane Fahey, also an engineer, has a Bachelor of Building degree and studied for his Masters in Science majoring in 'Acoustics'. He looks after admin

with the aid of Kristen Wolek, Operations and Marketing Manager (Kristen also has engineering skills). Assistant Engineer is Jason Blackwell, and it's an efficient though casual facility.

Kevin Carmody was the first act recorded at Megaphon on an 8-track back in 1987/88. The studio gradually upgraded to 24-tracks in 1989 for Dave Steels' first solo album. Shane says they've been lucky over the years with good deals on equipment purchases and sub-rentals. These guys are not adverse to travelling our vast continent in a never-ending quest for equipment, acoustic and construction materials (new and used). They acquire and use whatever they think will work, from 44 gallon/200 litre drums embedded in walls, primo imported acoustic

battens and custom board, to state of the art equipment.

Luck has been on Megaphons side in more ways than already mentioned. The winning of a fourteen week recording contract with 'Midnight Oil' in 1992 finally enabled Megaphon to approach their bank for construction and equipment funding. Luck again, a young and foresighted bank manager saw the light (that's a change) and there you have it. Megaphon has been an experiment. But! Sitting in the large control room looking down the length of one of the three recording rooms, with masses of natural light warming your body and the aroma of Tassie Oak clearing your mind, you know the experiment worked.

Having experienced all the trials and errors with Megaphon, Guy and Shane then turned their minds to what is now regarded as AirMotion Studios. Having once been rehearsal rooms, they had now become the receptacle of all the trash and leftovers from the renovation of Megaphon,

*(cont. over)*



## EX-TRACK

*(continued)*

**Future Technology?** Remember **Skyhigh Recording Studios** in Newcastle? They've touched down in Sydney and joined forces with the team at Darling Harbour Studios. Called **48V** (pronounced '48 volt'), they're now a part of **Phantom Records** and are providing the recording power behind the indie label. (Geddit? 48 volt, phantom power? Ahem...) Studio vibemaster **Rob Taylor** says they're going better than ever, with a total of 48 tracks courtesy of a Studer A80 analogue 24-track and a Tascam DA800 digital 24-track DASH recorder. They've also got one of the only Amek Hendrix consoles in Australia, with 56 inputs and full automation. To round it all off, they've got a Midi suite operated by **Larry Van Kreidt** of **Def FX**. Getting off to a good start, their first customers were **The Screaming Jets**. Sounds like a happening place... Give studio manager **Clare Britton** a call on (02) 211 1474. • **Mother lode?** The staff of **Rich Music Studios** are digging for gold with improvements to the facility and

*(continues)*

## Information Communication Presentation

*Much more than an exhibition!*

Products and services demystified in a definitive technology exposition.

Includes Seminar Workshops aimed at the end user with sessions on hardware, software and system application.

M U L T I C O M M

CONVERGING 94 TECHNOLOGIES

Sydney Convention and Exhibition Centre, Darling Harbour 3-5 May 1994

\*The first 100 registrants will be placed in a draw for a Sharp Personal Organizer!

Please complete and return by fax or post to: Con-F

RWV Seminars, PO Box 562, Camberwell 3124.

Ph. (03) 882 8039 Fax. (03) 882 1855

- I am interested in attending one day \$95  
 I am interested in attending all three days \$225

Name: .....

Company: .....

Address: .....

..... P. Code .....

Position held: .....

Phone: ..... Fax: .....

METHOD OF PAYMENT

- Crossed cheque payable to RWV Seminars  Bankcard  
 Mastercard  Visa  Am. Express  Diners Club

Expiry date ..... Signature .....

On receipt of registration and payment you will be sent your exhibition and seminar pass

OFFICE USE ONLY: Fee received ..... Date .....



anything

AUDIO



“Unlike some daytons 'specials' offered, we actually do discount & offer real service from our audio professionals. Sounds simple, but it's the simple things that's made our monthly specials 'special'.”

MARCH SPECIALS



MICROPHONES



E-100



E-200

You've heard lots about them, check out the review in Dec/Jan Connections. Made in the USA, CAD mics offer real value & out perform mics triple their price, plus they look great. Studio condensers, live, installations, podiums, choir, overhead, boundary mics, plus heaps more.

Full 2 year warranty. Call us for our special deal on CAD Mics.



K & M KÖNIG & MEYER

STANDS  
STANDS  
STANDS



Sick of cheap stands that keep breaking down, AND not being able to get parts?

Konig-Meyer are simply the best manufacturer of every type of stand. They offer:

- \* Quality - 50 years experience
- \* 3 - year guarantee
- \* Spare parts always available

Call us now for the best deal on quality Konig-Meyer stands.

2 5 6 VICTORIA ROAD  
GLADESVILLE NSW 2111  
A U S T R A L I A

TELEPHONE (02) 879 6788  
FACSIMILE (02) 817 1049

STUDIOS

WORKBENCH (continued)

power from the motor.

In this unit the infra-red devices had aged, so the shut-off circuit was operating 'flukey'. Sometimes it'd cause the motor to cut out. The receiver and transmitter weren't available ex-stock - they've gone on back-order - but we were able to fit a new pinch-roller and drive belts and give the machine a basic once-over.

The point of this story is: how much money is it wise to spend on a unit this old? Certainly, for the cost of replacing the heads, and giving the machine a thorough overhaul, a new model could be purchased which in all likelihood would have significant improvements over this model. However, the owner was pretty satisfied with his machine the way it was - if it hadn't been for the erratic behaviour of the shut-off circuit he probably wouldn't have had the deck serviced.

•This exact problem came up again with a sony TC-766 open reel, selectable for 2 or 4 track recording. The original specs for this model were very good, and being the second model of this type through the workshop recently, I checked parts availability.

Heads, pinch roller, drive belts, brake bands etc -these parts would have to be back-ordered from Japan. And here's the rub - they were all obtainable on back-order, except the main capstan belt.

So, if and when this belt breaks, or is simply too brittle to continue performing properly, this machine will be knocked out of action. I thought I would ring the owner of the first one of these models which had come in, and just let him know what I had found. His reaction was quite interesting - he was far from impressed, and enquired as to whether it wasn't possible to obtain a generic belt from a parts supply house. Well, it may or may not be. But it does raise the question once again of how you depreciate a machine, and how much it is sensible to spend on maintaining a unit once the original manufacturer has discontinued support for that model. If this machine had cost, say, \$1200 when purchased 10 odd years ago, then the residual value is nil.

Perhaps the solution is that when a machine has been judged to have paid for itself, it should be retired to a support role, and a new unit purchased to take on the workhorse role.

Howard runs Studio Solutions. Call (02) 906-4363, fax (02) 439-6444.

MEGAPHON (continued)

the decision to establish a small, practical and lower priced 24 track facility was made. So the clean-up and renovations began. A new partnership was formed between Megaphon, Andrew 'JT' Tebbitt and Murray Richardson which would fund the new project. Now the gear might not be as state of the art as Megaphon nor could it be said that these are large control and recording areas, but the rooms are what can only be described as 'horn'.

Tasteful decorating (mostly by Guys' wife Gigi in the recording room) gives an act the opportunity to work in an environment normally reserved for the corporate client and at a rate that should please.

Shane and Guy have ambitions, both for their studios and personally. They believe in clarity and natural audio recording, often going to unusual lengths to achieve a different (though analogue) sound. While not totally adverse to the idea, they believe they have avoided being swept up in the digital revolution and like a lot of people, they are sitting on the fence observing technological advances. They both enjoy and try to achieve the sounds of the sixties when, audio reproduction was largely experimentation with the acoustic environment.

Guy having already recorded Latin American and Renaissance music and Shane enjoying recording 'the art of sounds' and poetry, the personal ambitions of both Shane and Guy, look diverse. Enjoying, what can only be described as a "hybrid" outlook on audio and music, they look forward to recording everything, from Soundtracks to Grunge and Pop music, to Ethnic and Orchestral. Promoting their own label, in the future, is also not out of the question.

A lot of hard work and a little luck make these studios worth checking out.

•By Caroline Grafton.

NEW SIMMO SOUND SCHOOL

SYDNEY: The Institute of Sound Production is a new sound engineering school aiming to provide industry-focused and relevant training in studio and live sound reinforcement. The first part-time course is scheduled to commence in mid-March, with an intensive full-time course available later in the year. They've got their own 24-track recording studio equipped with some of the newest generation equipment. Greg Simmons is chief. Call (02) 212 3101 for further details.

## DA-88 (Continued)

Physically the DA-88 is an irony to other existing units in that it employs smaller tapes and yet, is much bulkier in dimension. A world away from the 1/2" tape used for eight analog tracks on previous Tascam's: this Hi-8 stuff carries eight tracks and a data subcode area in just under a third of an inch. The other twist here is that, normally, 'borrowed' tape formats such as VHS and high speed cassette multi-tracking mean that a tape is quite often much shorter than it's specified time allowance. In this example of video tape format, using a PAL/SECAM tape means a tape labelled P5/90 minutes will actually run for 113 minutes!

**PHYSICAL:** Up front there are eight, tall Peak Level LED ramps placed on the right hand side, each with its own Record Select button. These are grouped with the timecode, chase and clock selectors amongst which you can access Word clock and Video sync'ing as well as Chase and striping functions. When powering up the DA-88, the LED ramps scroll across as a large set of moving letters that spell TASCAM. Very interesting guys!

Down the middle of the fascia is the button which selects the two allowable tape frequencies of 44.1 and 48 kHz. This is accompanied by the Format button which you use, along with Rec/Play to format the tape at either of the latter frequencies. The manual notes specifically that if you interrupt a Format you should return to the beginning of the tape and start again, as well, it is impossible to format a HI-8 tape that has previously been used in a video recorder.

Still in the centre of the panel, the remaining space is used for the Shuttle function and its dial. Shuttling allows bi-directional previewing at speeds from 1/4 to 8x normal play speed and this function also seems to replace the age old tradition of being able to hold down Play and FF/REW for fast searching. This works well at some of its speeds in that you can make quite a bit of sense of what sound portions are flying past. These portions are of a size that we could "scrub" down to about three frames at a time audibly and we could nudge the tape a frame

at a time without audio present. The left of the fascia is topped by the tape loading door under this is an indicator panel encompassing status LEDs and the Hours/Minutes/Seconds/Frames display which are all very easy to read. Consuming the rest of the space are selectors for Varispeed, Analog/Digital input, remote control; there are the usual transport controls as well as smaller buttons for inbuilt locator points (2 of), punch in/out functions and data increment/decrement.

Around the back the recorder has various proprietary remote control sockets, a multi-pin for attaching a remote set of meters as well as a multi-pin for digital I/O. There are a pair of BNC connectors for digital word-sync input/output next to which is a jack socket for foot switch punch in/out recording and next to this is a small rotary selector for giving the unit an ID number in a chain of a possible 16 machine/128 track set up. Under this is the panel that can be removed to fit the optional "sync" board which will enable the DA-88 to perform it's many striping and chasing functions outside of the Tascam realm. Consuming the rest of the rear panel is sixteen RCA sockets for audio I/O at -10dBV and two multi-pin sockets which give and receive +4dBm balanced audio lines.

**USING THE DA-88:** We obtained a specimen from the retail floor and brought it to the studio just as if we were genuine purchasers. To make absolutely sure that we were on the right track we purchased a SONY brand P5/90 MP HI-8 tape. (Sony, we are led to believe, were the inciters of this format) Loading the tape was first, and here you should be careful to push the tape 'straight in' as it is easy to 'skew' the tape and get it stuck in the plastic entry port.

Next we formatted our fresh tape at 44.1kHz and, this done, proceeded to check out Memo points and locating, rewinding etc! Entering locates is dead easy and can be done on the fly or by simply requesting a point on the time display. Getting from one place on the tape to another is very fast and the DA-88 is intelligent here in that as it leaves and approaches a point it will select various tapes speeds, presumably to avoid tape damage and to assist in the 'spot on' locating that it performed.

Still before we recorded any-

thing we engaged the 'Play' mode to watch the machines' response time. It was extremely quick to react and confirmed what we had already seen at the TASCAM trade stand last year when the importer showed us 2 x DA-88's rapidly chasing and locking to a 24 track reel recorder. We couldn't personally do this with our example because the optional sync card is currently unavailable and therefore not fitted to our 'pseudo purchase' machine of which we now speak.

The aforementioned playing of our formatted/un-recorded tape did, however, reveal an interesting scenario. At random, all eight tracks were intermittently 'spiking' and the LED ramps were doing the same routine but at different times to the clicking sound. UH-OH! Pushing on we started recording and by monitoring the outputs during this time our source material emitted itself from the machine just as it had gone in, no added noise and no alteration of sound colour. Playing back our recording was less successful though as it was plagued with a new set of intermittent spiking which now concurred with the meters. This aside, the recorded sound was excellent.

Fearing we had incorrectly formatted the HI-8 tape we went back to the beginning and started again. This time we chose the optional 48kHz formatting frequency, re-read the instructions to be sure and then off we went. Well, just as before, playing a formatted/un-recorded tape revealed a non-synchronised set of meter and audio spiking. "Okay", we thought, "might be the tape so let's record on this new 48kHz formatting to confirm it." UH OH again; the recordings now worked perfectly and sounded nothing short of shit hot and crystal clear.

This is all very confusing to us because the fact that this final recording attempt worked perfectly would seem to leave a dispute as to whether the machine, the tape we used, or both were at fault. Anyway, stay tuned to this magazine for we assume that there will be more printed in the near future on this particular matter, but for now.....

**SUMMARY:** All our investigations of this Tascam model indicate that it will be somewhat of a winner in the more professional

(continued over)

## EX-TRACK

(continued)

service, including a new lounge/relaxation area for Studio A, a 24 hour maintenance team, and the addition of wood panelling to the live room in Studio A. Proposed but yet-to-be completed additions include a new live room called 'The Sandpit' (claimed to be the first in Australia with sandstone walls), a 24/32-track ADAT studio, and a comprehensive Midi suite. Tie lines will be available between all studios, of course. Call Rich on (02) 264 7734. • **Gold guitars...** The guys from **Enrec Studios** did well at the **Tamworth Festival** with the **Pixie Jenkins** album 'Kindee' winning the Gold Guitar award for **Best Instrumental Of The Year**. That makes two for Pixie, who won the same award last year for his previous album! If you're doing country music, why not give the guys at Enrec a call on (049) 36 1376. • **Making CDs?** The dynamic duo at **CD Bureau** have a new address: Suite 10, Ground Floor, 301 Castlereagh St, Sydney NSW 2000. In addition to their real-time custom CD manufacturing, they also offer mass replication in quantities of 500 and 1000 discs. Prices vary according to your printing requirements, but a typical 500 disc job will cost you around \$2440 for the lot. Call CD Bureau on (02) 212 3101. • **Call the exterminators!** Looks like they've got insect problems at **Damien Gerards**, with **Bughouse** taking over Studio B for final overdubs on their new album. The insectivorous **David 'DP' Price** and **Mike Woods** are cleaning up the bugs, and are also the team driving the **Front End Loaders'** new album. Meanwhile, DG's **Apogee filters** are travelling around the country on hires from **Gotham Audio** and then **Platinum Recording Studios**. Also at Damien Gerards, they've finally put together their long awaited **Compact Disc Display** which sports over 50 discs and vinyl releases from the studio's 11 year his-

(continues)

## DA-88 (Continued)

digital recording realm, it looks good, it's got the right interface functions, it has all the right varispeed and track lag facility needed for sample accurate digital transfers and it has a great tape management system.

**However:** as we are paid to be "End User" reviewers we are supposed to imagine that we have purchased the particular units we write about. So, after parting with our 'imaginary thousands of dollars', making a very real trip to purchase the correct tape and then rushing back to the studio to "get into it" with our new toy, we can only say that we'll have to pretend to be disappointed with this particular 'pseudo purchase'.

• **Editors footnote:** We choose to run with our reviewers comments in full because we pay them to fully review a product. Sometimes the individual piece of equipment has a bug, like much technology you need to be patient and 'bed down' a new purchase. Fact of life.

## DA-88 SPECIFICATIONS

Recording Format	4-rotary head digital
Tape:	Hi8 video tape
No. of channels	Eight plus subcode area
Recording time:	108 min. using P6-120 tape 113 min. using P5-90
Tape speed:	15.9 mm per second
Fast forward/rewind:	Approx. 100 times play speed
Digital I/O:	T/DIF (Tascam digital interface) format, 15 pin D-sub connector
Analog input:	25 pin D-sub, +4dBm (balanced) RCA jack x 8, -10dBm (unbalanced) as above
Analog output:	as above
Sync input:	15 pin D-sub connector
Sync output:	as above
Word sync input:	BNC connector
Word sync output:	as above
Sampling rate:	44.1/ 48 kHz
Quantization:	16 bit linear
Pitch control:	+/- 6% in 0.1% increments
Frequency response:	20 Hz to 20 kHz, +/- 0.5 dB
Wow and flutter:	forget it, immeasurable!
RRP	\$13,398-

## EX-TRACK

(continued)

tory. Call Marshall or Elia at **DCs** on (02) 692 9915 and arrange a time for a visit. • **BYO Engineer!** If you're looking for a recording deal and a half, why not call **JMF Sound Studios**. They're currently offering 15 hours of recording time in their 24-track recording studio for just \$300! The catch? You've got to supply your own experienced engineer. If that sounds like a good deal, give them a call on (02) 790 4097. • **Quick upgrade: Main Street Studios** have recently installed a new G16 Fostex multitrack recorder, giving them 16 tracks on half inch tape. Fostex's **G-Series** multitracks use **Dolby S** noise reduction and offer outstanding performance, especially when set up for **Ampex 499** tape. Call Rob or Tim on (042) 83 4515 and ask them what they think about their new machine. • **More Foghorn:** The prestigious **Selection Chart** for indie radio station **3RRR** (Melbourne) puts **Blue Ruin's** latest release at number 10. As Marshall at Foghorn says, "If you haven't heard the single **'Tattoo Tears'** yet you must have been fighting a bushfire or something." • **Simon says?** Slightly strange fax from **Simon Tonx** at **Sony Music Studios**, who we couldn't get in touch with at press time. Simon tells us that "the Galaga machine is cooking, new monitors are being installed, and David's head looks like a furry golf ball". Well, we know what a **Galaga** machine is, but we don't know what sort of monitors they're installing, and we certainly don't know who David's hairdresser is! Find out for yourself by calling **Simon** at **Sony** on (02) 332 0320. • **Hunting and collecting...** Graeme Storer at **The Enterprise** is still looking for songwriters and particularly vocalists for their rapidly expanding songwriting collective. Call Graeme on (02) 564 3225. • **SAE Studios** now have four ADATs to add to their collection of recording and training equipment. Call the **SAE** on (02) 211 3711. • **Blind Trojan**

(continues on page 47)

# MASTERING With Paul Bryant

## OUT OF SIGHT AND OUT OF MIND

A lot of people in the Australian recording industry still don't take the mastering process seriously. They are less interested in mastering today than in the days of vinyl, when there was enough "black magic" and enough disasters to make people want to get involved in the mastering process.

Now, Australians happily send their un-edited, over-modulated, mute-filled DATs off to Asia (it's cheap mate!) and wonder why their masterpieces sound inferior to the latest discs from those infernal Americans.

CDs and digital recording have made people complacent but a comparison of just the volume levels on three to four CDs will show how much things can vary.

QUOTE: "TO RECORD FOR SIX MONTHS AND THEN GIVE THE TAPE TO AN ENGINEER WHO'S NEVER HEARD IT BEFORE AND EXPECT HIM TO TURN IT AROUND IN TWO HOURS IS NONSENSE".

- Tony Cousins - Metropolis Mastering, London.

The arrival of CDs coincided with the rapid growth in budget studios and home recording. The result was that increasingly master tapes lacked the polish that large professional studios supply.

Disc cutting had required a reasonable level of skill just to operate the lathes so that tapes supplied for mastering usually got some expert assistance, where needed, to improve finished product.

However, it soon became clear that often this was not happening in CD master preparation.

Also, the widespread use of budget digital re-

(continued on Page 50)



## THAT NEW PARADISE SOUND

- ⊕ Only analogue offers you the absolute best in audio.
- ⊕ Only Paradise offers you the absolute best in analogue.
- ⊕ Recently upgraded 1/2" 2 tracks (x2)
- ⊕ Affordable rates

**PARADISE  
RECORDING STUDIO  
(02) 357 1599**



**1994**

*Connections Magazine announces Australia's first*  
**Truly Brilliant Technical Awards**

*Vote now. Awards handed down during ENTECH '94 tradeshow.*

# STUDIO & RECORDING



Project studio multitrack recorder	<input type="text"/>
Multitrack recorder, 24 tracks or more	<input type="text"/>
Hard Disk recorder, and/or software	<input type="text"/>
DAT recorder	<input type="text"/>
Project studio mixing console	<input type="text"/>
Professional recording studio console	<input type="text"/>
Main studio monitors	<input type="text"/>
Nearfield studio monitors	<input type="text"/>
Valve mic, vocals	<input type="text"/>
Valve mic, instrumental	<input type="text"/>
Condenser mic, vocals	<input type="text"/>
Condenser mic, instrument	<input type="text"/>
Preferred tape, mastering	<input type="text"/>
Preferred tape, multitrack	<input type="text"/>
Preferred tape, DAT	<input type="text"/>
Studio EQ module or insert, external	<input type="text"/>
Studio cable: preferred brand	<input type="text"/>
Studio noisegates	<input type="text"/>
Studio effector	<input type="text"/>
Studio limiter	<input type="text"/>

Best Engineer	<input type="text"/>	For Product/Session:	<input type="text"/>
Best Assistant Engineer	<input type="text"/>	For Product/Session:	<input type="text"/>
Best Producer:	<input type="text"/>	For Product/Session:	<input type="text"/>
Best Mastering Engineer:	<input type="text"/>	For Product/Session:	<input type="text"/>
Best Music Studio	<input type="text"/>	Best Post Production Studio:	<input type="text"/>
Best Project/MIDI studio:	<input type="text"/>	Located in (City):	<input type="text"/>
Best MIDI Programmer:	<input type="text"/>	Best Overall Studio Complex:	<input type="text"/>
Best CD Manufacturing Plant:	<input type="text"/>	Best Cassette Dupe Plant:	<input type="text"/>
Best Rehearsal Studio:	<input type="text"/>	Located in (City):	<input type="text"/>
Best Studio Equip. Supplier:	<input type="text"/>	Located in (City):	<input type="text"/>
Best Studio Equip. Hire:	<input type="text"/>	Located in (City):	<input type="text"/>

*Note for as many or as few categories in any section - your choice!*

## OPEN CATEGORY

Best Production Manager:	<input type="text"/>	For (Tour/Show )	<input type="text"/>
Best Tour Manager:	<input type="text"/>	For (Tour)	<input type="text"/>
Wooden Spoon Award to:	<input type="text"/>	Wooden Spoon Award for:	<input type="text"/>

# AWARDS NIGHT

The ENTECH AWARDS will be handed down at a major industry awards function to be held one evening during the ENTECH '94 Trade Show, Sydney Exhibition Centre, between October 6th - 8th inclusive.

**AWARD FUNCTION TICKETS:** On sale August 1, see Connections **AUGUST** issue for details.



# SOUND: Touring, Theatre, Installation

Mixing Console, Theatre	<input type="text"/>
Mixing Console, Touring	<input type="text"/>
Mixing Console, Monitors	<input type="text"/>
Small Mixing Console, 24ch & under	<input type="text"/>
Speaker system, Theatre	<input type="text"/>
Speaker system, Touring	<input type="text"/>
Speaker product, installation	<input type="text"/>
Speaker brand pref, custom speaker systems	<input type="text"/>
Monitor wedge, complete	<input type="text"/>
Speaker brand pref, custom monitor systems	<input type="text"/>
Speaker processor, system controller	<input type="text"/>
Crossover, system network	<input type="text"/>
Compressor limiter, Dynamics controller	<input type="text"/>
Equaliser product	<input type="text"/>
Design/analyst or other live audio software	<input type="text"/>
Effector, reverb, and/or delay	<input type="text"/>
Enhancer, Audio 'sweetener'	<input type="text"/>
Amplifier, touring	<input type="text"/>
Amplifier, general use PA & hire	<input type="text"/>
Amplifier, 100v line installation	<input type="text"/>
Microphone, vocal	<input type="text"/>
Microphone, instrument (general)	<input type="text"/>
Microphone, drums (general)	<input type="text"/>
Microphone, kick drum	<input type="text"/>

Powered mixer, model & brand	<input type="text"/>
Compact Speaker system, model & brand	<input type="text"/>
Preferred microphone cable type	<input type="text"/>
Preferred mult core cable type	<input type="text"/>
Preferred microphone connector model & brand	<input type="text"/>
Preferred speaker connector model & brand	<input type="text"/>

Sound Engineer, Touring	<input type="text"/>	➔	For Tour:	<input type="text"/>
-------------------------	----------------------	---	-----------	----------------------

Sound Engineer, Theatre	<input type="text"/>	➔	For Show:	<input type="text"/>
-------------------------	----------------------	---	-----------	----------------------

Monitor Engineer	<input type="text"/>	➔	For Show/Tour:	<input type="text"/>
------------------	----------------------	---	----------------	----------------------

System Engineer	<input type="text"/>	➔	For Show/Tour:	<input type="text"/>
-----------------	----------------------	---	----------------	----------------------

Best complete touring PA	<input type="text"/>	➔	From this company	<input type="text"/>
--------------------------	----------------------	---	-------------------	----------------------

Best Installation:	<input type="text"/>	➔	Completed by:	<input type="text"/>
--------------------	----------------------	---	---------------	----------------------

Best Installation Design by:	<input type="text"/>	➔	For Installation at:	<input type="text"/>
------------------------------	----------------------	---	----------------------	----------------------

Best After Sales Service	<input type="text"/>	➔	For Product:	<input type="text"/>
--------------------------	----------------------	---	--------------	----------------------

Best Venue Audio system	<input type="text"/>		Best Sound Hire/Production Co	<input type="text"/>
-------------------------	----------------------	--	-------------------------------	----------------------

Most helpful Venue Audio person	<input type="text"/>		Most helpful Hire/Production person	<input type="text"/>
---------------------------------	----------------------	--	-------------------------------------	----------------------

*Vote for as many or as few categories in any section - your choice!*

**VOTES WITHOUT DETAILS COMPLETED (BELOW) NOT ACCEPTED! (SORRY!)**

**important** ➔

You can vote for as many or as few of the categories as you like. But you **MUST** complete the section below or your vote will be rejected. Our Auditor **will** verify voters at random.

Name:

Employer:

Occupation:

Contact phone:

**STATEMENT:** (1) I am eligible to vote for the categories I have selected, because I have **NOT** voted for myself, or any category that benefits myself or my employer, in any way ... and: (2) This is my **ONE** and **ONLY** vote, and it's genuine. I am happy to qualify myself further.

Signed:



# LIGHTING, MECHANICALS

## Touring, Theatre, Club & Industrial

Memory Console Theatre	<input type="text"/>
Memory Console Touring, Industrial, Hire	<input type="text"/>
Moving Light and other DMX devices, Console	<input type="text"/>
Moving Light Dedicated Contoller	<input type="text"/>
Installation/architectural Dimmer	<input type="text"/>
Dimmer touring	<input type="text"/>
Moving Light, compact category	<input type="text"/>
Moving Light, full size category	<input type="text"/>
Colour scroller	<input type="text"/>
Colour changing luminaire	<input type="text"/>
Effects Lighting Product	<input type="text"/>
Best Luminaire Manufacturer	<input type="text"/>
Fog machine	<input type="text"/>
Best Colour filter product	<input type="text"/>
Most reliable lamp (globe) manufacturer	<input type="text"/>
Architectural Lighting Product	<input type="text"/>
Most innovative lighting manufacturer	<input type="text"/>
Best Video installation product:	<input type="text"/>

Lighting Designer: THEATRE	<input type="text"/>	For Production:	<input type="text"/>
LX Designer: TOUR/Industrial	<input type="text"/>	For Tour/Show:	<input type="text"/>
Best CLUB lighting designer	<input type="text"/>	For CLUB/Venue design at:	<input type="text"/>
Best LASER designer	<input type="text"/>	For LASER work on (show)	<input type="text"/>
Board Operator: THEATRE	<input type="text"/>	For Show:	<input type="text"/>
Board Operator: TOUR/INDUSTRIAL	<input type="text"/>	For Show/Tour:	<input type="text"/>
Most helpful Lighting Person: Venue	<input type="text"/>	Venue this helpful person works at	<input type="text"/>
Most helpful Lighting Person: Hire Co	<input type="text"/>	Hire Co. this person works at	<input type="text"/>
Best After Sales Service (Co.)	<input type="text"/>	For Product:	<input type="text"/>
Best Venue for lighting facilities	<input type="text"/>	Best Lighting Hire/Production Co	<input type="text"/>
Rigging/flying product, touring and/or theatre	<input type="text"/>		
Manufactured/built by:	<input type="text"/>		



**No stamp required!**

Mail this form to:  
**ENTECH AWARDS,**  
 FREEPOST 9,  
 Epping NSW 2121

Entech Awards are audited by  
**Partlett, Chave & Rowland**  
 Entertainment Accountants,  
 Bruce Rowland, Sydney.  
 Call (02) 299-8487



Connections South Pacific  
 Entertainment Technology Tradeshow.  
 Sydney October 6 - 8, 1994

# EX-TRACK

(continued)

**Pie?** Well known **Connections** journo **Bruce Waite** will soon be engineering and producing an album at **Troy Horse Studios**, for someone too famous to mention. Call Troy on (02) 557 3129 to find out... • **Hello Melbourne...** Lots of news from **Studio 52** in Melbourne, who report that Studio One is booked out until late March with projects for **Peter Cupples**, **Geoff Achison**, **Dive**, **Indian** (who appeared on **NuMusic #6**) and **Mark Emberg** (first heard on **NuMusic #7**). In addition, their **NuMusic Sampler CD Series #8** is due for February release and features eight local and 11 interstate artists. They're also purchasing a couple of **Fostex RD-8 ADAT**-compatible recorders in the near future for Studio Two, and are currently offering hot deals with **Live to DAT** recordings from \$200 to \$300. Call them on (03) 417 7707 for further details. • **And Hello Brisbane...** News from sunny Brisbane is that **Grevillea Recording Studios** have just added some Behringer noise gates and a **Behringer Ultrafex** to their effects rack. These Behringer units are making a big noise throughout the industry, so to speak... Call **Malcolm Jacobson** at Grevillea on (07) 262 8422. • **Total Advertising Production Studios** have added two Alesis ADATs and a BRC to their list of equipment. Call **Anthony** at TAPS on (074) 79 2277. • **Serious software...** News from **Gotham Audio** is that they've updated the software on their **Sony PCM 3348** 48-track digital multitrack, taking it up to version 2.1 and adding features including 48-track digital track bouncing and stereo sampling. Their 64-channel **SSL** console now contains the latest **G Series 3.5** software, which includes improved disk management and a new off-line **Mix Trim** facility. Digital editing and mastering facilities are now

(continues)

ARTIST	PRODUCER	ENGINEER/S	NOTES
<b>New South Wales</b>			
<b>Alrmotion Studio</b>		Contact Kristen Wolek (02) 550-3863	24 Track
Wendy Matthews	Tim Pinn	Chris Betro	Album Demos
Steve Wishart	Steve Wishart	Shane Fahey	Mastering/Editing for CD Release
John Brassil	Jim Denley	Shane Fahey	Soundtrack for a Video
<b>All Music Manufacturing</b>			
DJ Bobo	Pro DJ Intl	Paul Bryant	Geoff Sturre (02) 557 1169 Mastering
Carroll Byrne	Carroll Byrne	Paul Bryant	CD Master
Astral Taxis	Jeff Cripps	Geoff Sturre	CD Master
Barlow Mei	Doug Henderson	Paul Bryant	CD Master
Bass Culture	Pee Wee Ferris	Paul Bryant	Vinyl Master
<b>A Sharp Studio</b>			
Astral Taxi	Jeff Cripps	Jeff Cripps	6 Track CD
Heart Worm	Jeff Cripps	Jeff Cripps	Demo
Cyanide	Jeff Cripps	Jeff Cripps	Demo
<b>Bandit Audio</b>			
Coloured Stone	Brett Coupland	Brett Coupland	Album
Bird Dog	Brett Coupland	Brett Coupland	Album
<b>Bush Tracks Recording Studio</b>	Ruth & Dave (066) 89 1290	24 Track	
Vivid Image	Band/D. Highet	Dave Highet	Album
The Bourkenbacks	Band/D. Highet	Dave Highet	Album
Gary Dennis	G. Dennis/D. Highet	Dave Highet	Demos.
Col Phillips	C. Phillips	Dave Highet	Demos.
<b>Charing Cross Studio</b>			
B.U.M.	Rob Younger	Contact Gordon Hervey (02) 387 8362	16.24 Track
Bughouse	Paul McKercher	Alan Thorne	EP Mixing
Scarlet	Band	Tim Powells	Album Mixing
Vanilla Chainsaws	John Bee	Martin White	Demo's
Burning Orphans	Karl Christie	Daniel Gilliland (Asst.)	E.P.
<b>Damien Gerard Studios</b>			
Gigantic	Tim Powells	Tim Powells	Album Mixing
Bughouse	Steve Bug	Contact Ella Bell (02) 660-8776	16/32 Track
Pale Riders	Dave Steel	Tim/Dave	Album
Drue Hoille	B. Price	Tim/Dave	Album
Ian Moss	Mark Moffatt	Russ Pilling	Album
<b>Enrec Studios</b>			
Sharon Mann	Steve Newton	Mike Woods	Pre Production
Jim Hyne	Steve Newton	Ed or Steve 049 361 391	
Tamworth Festival	Steve Newton	Steve Newton	Album
<b>Festival Studio</b>			
King Clam	Aya Larkin & Band	Steve Newton	Live Recording
Jeff Vincent	Keith Cohen	Vicki Eldridge (02) 660 4022	32 Track
Jeff Vincent	Greg Henderson	Mark Thomas	
Pippa Grandison	Tim Whitten	Mark Thomas	Album Tracks
Swirl	Ben Aylward	Mark Thomas	Album Tracks
<b>Hullabaloo</b>			
Disney Live	Heaton/McGarvey	Glenn Heaton 02 684 2039	24 Track
Watershed	Watershed	Glenn Heaton	Various Tracks
Cry Wolf	Cry Wolf	Glenn Heaton	Album
Skinny Guinea Pigs	Band	Dave Vaughn	Demo
Bill	Bill	Dave Vaughn	Demo
TNT/Comet	Glenn Langford	Glenn Heaton	Demo
<b>JMF Sound Studio</b>			
The Bow/Weavils	Keith Combs	Geoff McGarvey	Jingle
Eva Spata	Chris Gray	Contact Fran Esther (02) 790 4097	24 Track
Leanne Imber	Paul Gray	Keith Combs	Demo
The Tony Martin Band	Tony Martin	Ralph Esther	Album Tracks
<b>Main Street Studios</b>			
Wougawilli	Rob Specogna	Paul Gray	CD Single
Thousand Plane Raid	Ben Robertson	Ralph Esther	CD Album
Scott Radburn	Self	Rob Specogna & Tim 042 83 4515	CD Album
Inscape	Inscape	Rob Specogna	Demo
<b>Megaphon Sound Recording</b>			
Mal Eastick Band	Mal Eastick	Rob Specogna	Demo
<b>Paradise Studios</b>			
Cactus Child	Mark Moffatt	M. Nicholas	Demos
Ron Barry	Ron Barry	Studio Contact Guy Dickerson (02) 516 3917	24 Track
Cathy Harley	Cathy Harley	Guy Dickerson	Album
Drop City	Wayne Connolly	Bill Field (02) 357 1599	24 Track
<b>Powerhouse Studio</b>			
Richard Barocat	Doug Henderson	Tom Colley	Tracks
Morbid Curiosity	Brett Stanton	Mark Roberts	Tracks
Meryl Leppard	Leon Berger/Doug Henderson	Michael Stavro	Jazz Album
Big Men Fly	John Hresc	Wayne Connolly	Album Mix
Turnaround	John Hresc	Contact Craig Beck (02) 318 1220	24 Track
Glare	John Hresc	Doug/Craig	Demos
The Porkers	John Hresc	Brett/Matt Lovell	Demos
Barlos Mei	John Hresc	Doug/Craig	Album
<b>R&amp;R Recordings</b>			
CJJM	CJJM	John	E.P.
BYSA	R. Zimola	John	Single
Nu-Skin	R. Zimola	Craig Beck	Demos
Kathy Morrison	R. Zimola	John	Album
	R. Zimola	Doug/Craig	Album
	R. Zimola	Contact Robert Zimola (02) 624 4484	16 Track
	R. Zimola	R. Zimola	Album
	R. Zimola	R. Zimola	Demos
	R. Zimola	R. Zimola	Corporate Instructional
	R. Zimola	R. Zimola	Demos

YOUR MUSIC IS SAFE WITH US



# BASF

Studio Cube adverts HERE!  
Very special LOW prices - call  
Caroline. Space very limited!

### COMPLETE CUSTOM MANUFACTURE SPECIALISTS

For all your Manufacturing needs speak to Paul at Studio 52

- CD's & Cassettes
- Digital Compilation & Mastering
- Complete Artwork & Printing Service



(03) 417 7707

fax: (03) 417 5294



### 48 TRACK

ANCIENT FUTURE TECHNOLOGY

24 digital + 24 analog

Tascam + Studer

AMEK HENDRIX CONSOLE

Engineers: Rob Taylor

David Menderson

Phone: Fax: 211 1474 Mobile: 015 22 55 95 or 015 218 297

# EX-TRACK

(continued)

available using a Digidesign system running on Macintosh IIfx and Quadra 950 computers. Call Tom Kehoe at Gotham on (03) 879 9400. • **New manager:** Got a message from **George** from **001 Studios**, telling us that **Owen Bolwell** is the new studio manager and **Brett Taylor** is the new in-house engineer. Call 001 Studios on (03) 348 1300. • **New market:** Also in Melbourne, **Newmarket Studios** are doing well with a new 16-track studio currently under construction. Call Newmarket on (03) 329 2877 for further details. • **New partner:** **Jam Tin** announce that **Paul Sherrit**, live sound engineer for **Jimmy Barnes** and previously with **Diesel**, has bought a half share of the studio and they've added a 40 channel Aries console purchased from GUVT in Sydney. Their new studio opened on 20th February 1994, and is located at 5/20 Charlton Ave, Cheltenham,

(continues)

ARTIST	PRODUCER	ENGINEER/S	NOTES
<b>Rich Music Studios P/L</b>		Contact Jason Nairnsey (02) 264 77	
Scott Walker	Scott Walker	Randall Waller/Phil Munro	Album Mix
Tom Kazas	Tom Kazas	Tom Kazas	Album Tracking
Deathcon 1	Al Wright	Al Wright	Album Mixing
Larry Jenkins	Larry Jenkins	Fraser Stuart	Album
Invasion	Eddie Duquerin	Fraser Stuart	Single
The Maddisons	The Band	Russell Pilling	Album
Smashed Crabs	The Band	Phil Munro	E.P. Demo
Lee Cutelle	Lee Cutelle	Richard Muckee	Single
<b>Riversound Recording</b>		Contact K.O. (02) 534 3496 16 Track	
Ruby Jargon	Ruby Jargon/Greg Clarke	Greg Clarke	CD EP
Deely Stan	K.O. Kazokas	K.O. Kazokas	Demo
Kilswitch	K.O. Kazokas	K.O. Kazokas	CD Mix & Master
Boneyard	K.O. Kazokas	K.O. Kazokas	Demo
Joseph Cho	K.O. Kazokas	K.O. Kazokas	CD Vietnam Choir
Just for Kicks	K.O. Kazokas	K.O. Kazokas	Demo
Soul Food	K.O. Kazokas	K.O. Kazokas	Demo
Tony Deveaux	Tony Deveaux/K.O.	K.O. Kazokas	CD EP Track Laying
<b>S.A.E. Studios</b>		Tom Misner (02) 211 3711	
R. Krupski	Tom Misner/Mark Kennedy	Tom Misner	Album
Winterhouse	Tom Misner/Mark Kennedy	Album	
<b>Sony Music Studios</b>		Contact Ross Ahern (02) 332-0320 24 Track	
Rippa Grandison	Tim Whitten	Tim Whitten	Album
Boxcar	Boxcar	Adrian Bolland	Album
Pat Powell	Pat	Simon Tonx	Demo
Flicker	Tim Whitten	Tim Whitten	E.P.
Mighty Reapers & Margie Evans		Mark Thomas	E.P.
Fiona Stewart		Simon Tonx	Demo
<b>The Enterprise</b>		Graeme Storer 02 564 3225 8 Track/Midi Suite	
Ruth Consolidated Industries		G. Storer	Indonesian Produce Info.
Not for the Faint Hearted	N.F.F.H.	G. Storer	Demos/Pre Prod.
Hits Two		H.T./Storer	Demos
Enterprise Songwriters Group		(the usual)	Public Demos
<b>The Giant Production House</b>		Penny Seta (02) 555 8999	
James Dean		Gavin Dutfield/Paul Dawkins	Singles
Matt Finish	Peter Dawkins	Gavin Dutfield/Paul Dawkins	Single
Blue Thunder	Ian Miller	Gavin Dutfield/Paul Dawkins	Tracking
KAS	Ian Miller	Gavin Dutfield/Paul Dawkins	Single
<b>The Vault Studio</b>		Contact Michael Tame (02) 953 0332 24 Track	
Cactus Child	Mark Moffatt	Tom Colley	6 Track EP
Kellie Hoggart	Jason Redlich/Mark Ovenden	Mark Ovenden	Album
Ardijah	Brendan Morley/Ryan Monga	Brendan Morley	2 Singles
Charlotte Grase	Mark Ovenden	Mark Ovenden/Greg Henderson	Album

YOUR MUSIC IS SAFE WITH US



# BASF

SPECIAL OFFER

SPECIAL OFFER

SPECIAL OFFER

SPECIAL OFFER



Buy one of the highly acclaimed Panasonic SV3700 Pro DAT Recorders in March, 1994 and we will introduce you to the Denon range of DAT tape *absolutlly free*. The first box of 5 x R60DT's are on us.

Call now for participating dealers.

5 Myrtle Street, Crows Nest, NSW 2065  
Fax (02) 922-2043 Tel (02) 957-5389

STUDIO SUPPLIES PTY. LTD.

Write in Reader Service number: 162

# CM86

SUPERIOR FLEXIBILITY

You really only have to remember two things about the CM 86 mixer.....

**1 SUPERIOR FLEXIBILITY**

**2 SUPERIOR PERFORMANCE**

It's much simpler than trying to remember even half the unique features that the CM 86 has, like:



- Front-panel Aux assign switches
- Separate Tape/CD levels to Master and Aux outputs (for flexible background music set-ups)
- Pre-output overload indicators
- Assignable meter/headphone monitoring
- Super-low hum, noise, and distortion
- Independent mono switches on Master and Tape/CD
- Two Master output pairs: one XLR, one terminal strip, with independent level controls
- UL listing
- Flex bus in and out
- Individual phantom power switches
- Both terminal strip and XLR mic input connectors (with 1/4" line inputs)



.....plus a whole bunch of other functions you'd expect from any well-designed mixer. We would have added Rane's well-earned reputation for reliability and factory support to the list...but you already *knew* that.



**JANDS**  
A.C.N. 001 187 837

Jands Electronics Pty Ltd.  
578 Princes Highway,  
St. Peters, N.S.W. 2044, Australia.  
Phone: (02) 516 3622, Fax: (02) 517 1045

Write in Reader Service number: 117

(continued)

Victoria, phone (03) 585 1933. By the way, they're on the lookout for a two inch 24-track multitrack recorder. If you've got one for sale give them a call... • **Stompin' around up North:** News from **Mick Connolly of Troppo Sound** is that **Stompem Ground — The Broome Aboriginal Cultural Festival**, will be bigger and better than ever before in '94. Why not check it out if you're in the area. For details, call Mick on (091) 92 2394. • **CAAMA Music** tell us they've got a new release and signing with aboriginal solo artist **Michael Liddle**, who's released an EP titled '**If Love Is Real I'm Your Man**'. Call CAAMA on (089) 523 744. • And that's the news for March. **Caroline Grafton** is next with this month's sport, and **Julius** will present the weather. I'm **Greg Simmons**. Goodnight...

♦♦♦♦

SEND YOUR STUDIO NEWS to Connections, Fax (02) 876-5715, PO Box 439, EPPING 2121 NSW or call (02) 876-3530.

## Mastering (continued)

Recording systems which couldn't be edited meant that masters could no longer be spliced together in the control room, but would require specialised editing.

QUOTE: "A LOT OF PEOPLE DON'T ATTEND THEIR 'CUTS' WHICH IS MAD. IT COSTS A LOT OF MONEY AND YOU SHOULD TAKE A LOT OF CARE OVER IT." *Nick Mender - EMI A & R, London.*

Often the golden rule is that if the mix is great, leave it alone, but during the mastering process you can: Balance levels between tracks, Apply EQ, eg: to compensate for bad monitoring, Add Compression and/or Limiting to obtain a higher average level, Create fade ins and fade outs, Crossfade between tracks, Shortening and re-arranging of tracks, Add processing such as reverb,exciters, and sub-harmonics; and De-noise noisy sections.

Proper mastering can make a marginal recording OK, or a good recording great. But remember, a mastering engineer can't polish a turd any better than you can. •

*Paul is a mastering engineer at All Music Mfg, call (02) 557-1169*

ARTIST	PRODUCER	ENGINEER/S	NOTES
<b>Trackdown P/L</b>		Contact Jeff Watson (02) 550 6890 24	Track/8 A-Dat
Gondwana	Charlie McMahon	Kathy Naunton/Michelle Barry	Album,
Happy House	Daniel Denholm/Tim Ryan	Tim Ryan/Michelle Barry	Album
Priscilla (Movie)	Guy Gross (Composer)	Guy Gross	Film Score
<b>Tracking Station Studios</b>		Contact Martin Cass (02) 212 4801 24	Track
Hound		David Price	EP
Wayne Law	Martin Cass	Martin Cass	Album Prodn.
Martin Reeve		Steve Pomfrett	Album
3's Co Opera	Incy Wincy	Steve Pomfrett	Album
DFS Productions		Martin Cass	Film Score
Redneck Mothers		Steve Pomfrett	Album
<b>Troy Horse Studios</b>		Contact Kitty Blackman (02) 557 3129	
Vicious Hairy	Mary	Liberty	E.P.
Disneylist	Stuart Robinson	Liberty	E.P.
Dance Sound Track	Tony Lewis	Michael Lewis	Performance Piece
Trout Fishing in Quebec	Darren Atkinson	John Raff	Album
Paul Berry		Colin Wright	Album
<b>Wirra Willa Studios</b>		Contact Will Rout (02)605 1203 24	Track & Optical 8 Track Digital
Siman Kanaan	Ricky Agosti	Will Rout/Ian Cooper	Album
Midnight Strollers	Mick Ferguson	Will Rout	Album
Malcolm Baxter	Phil Stien	Ian Cooper	3rd Album
Times Variable	Bob Luxford	Dion Wilton	Film (Post)
Gilmo	Dion Wilton'	Will Rout	Film (Post)
<b>Queensland</b>			
<b>Grevillea Recording Studios</b>		Contact Malcolm Jacobson (07) 262-8422 24	Track
Simon Gardner		Malcolm Jacobson	C.D. Mastering
Transmission Communications	Dennis Remmer	Malcolm Jacobson	C.D. Mastering
Time Trax	Garry McDonald/Laurie Stone	Bruce Jacobson	U.S. T.V. Series
<b>Suite 16 Audio Productions</b>		Contact Studio Manager (07) 369 8733	
Katz on a Swing	Garry Smith	Julian Lynch	Demo Songs
Peter Roberts	Garry Smith	Julian Lynch	Demo Songs
Old Newspapers	Garry Smith	Julian Lynch	Jingles
Doug Parkinson	Garry Smith	Julian Lynch	Broncos Theme Song '94
<b>Total Advertising Production Studio</b>		Contact Anthony Marsh (074) 792277	
Sunshine Plaza	Barrie Morrisson	Anthony Marsh	Jingle TVC Prod.
Pelican Waters	Barrie Morrisson	Anthony Marsxh	Jingle TVC Prod.
<b>Victoria</b>			
<b>Allen Eaton Studio P/L</b>		Contact Robin Grey (03) 534 0752	
Lightning Jack	Bruce Rowland	Robin Grey	Film Score
Ring The Bells Backwards	Paul Grabowsky'	Robin Grey	Album
Aladdin	Bruce Rowland	Robin Grey	Film Score
Aladdin	Danny Beckerman	Robin Grey	Film Score
<b>Audio House Pty.Ltd.</b>		Contact Nikki Mackenzie (03) 532 0633 24	Track
Hyperion	G. Mackenzie	A. Derbyshire	Album
Amazone	G. Mackenzie	G. Mackenzie	Album
Lutz	G. Mackenzie	G. Mackenzie	Album
Thonatos	G. Mackenzie	A. Derbyshire	Demo
Mother Earth	G. Mackenzie	G. Mackenzie	Demo
<b>Bel Air Sound</b>		Contact Danny Olesh (03) 563 7887 24	Track
Jabulani	Band	Danny Olesh	Album
Jonestown	Band	Danny Olesh	E.P.
Channel 9	'Stam'	Danny Olesh	Advertising
<b>Gotham Audio</b>		Contact Tom Kehoe (03) 879 9400 48	Track
Eamon O'Dowd	Eamon O'Dowd	Laurence Maddy/Aaron Humphries	Corporate Theme Music
Richard Pleasance	Richard Pleasance	Doug Roberts/Aaron Humphries	Album Recording
Tommy Emmanuel	Tommy Emmanuel	Doug Brady/Aaron Humphries	B - Sides
Jenny Morris	Jenny Morris/Mark Forrester	Mark Forrester/Aaron Humphries	Album Tracks
Jenny Morris	Andrew Farris	Mark Forrester/Aaron Humphries	Single Mix
Takao Hariuchi	Hisashi Sato	Susumi Iguchi/Myahara	Vocal O'dubbs & Mixing
<b>Hot House Audio</b>		Contact Cryss (03) 525 3703 24	Track
Debra Byrne	Debra	Ross Cockle/Cryss	Single B Side
Steve Lucas	Craig Harnath	Stuart Day/Cryss	Album Mixing
Dragonfly	Craig Harnath	Stuart Day/Cryss	E.P.
Choice	Band	Paul 'Woody' Annison/Cryss	Demos
Base Culture	Eternal/Pee Wee Ferris	Tony Espie/Cryss	2 12" Mixes
Mother Tongue	The Band	Cryss	Single Mixes
Steve Moffat	Steve Moffat	Stuart Day/Cryss	Tracking
Def Ryme	Band	Paul 'Woody' Annison/Cryss	Additional Tracking
N.A.M.	Band	Bruce Johnson/Danielle Moussard	Demos
<b>001 Recording Studios</b>		Owen Bolwell(03) 348 1300 24	Track/Midi Suite
Michael Fowler	Michael Fowler	Brett Taylor	Independent Release
Tlot Tlot	Tlot Tlot	Lawrence Maddy	2 Live Albums
Aaron Monks	George Siew Ooi	Brett Taylor	Single
The Family	The Family	Marty Robinson	Album
Bestial War Lust	Phil Pomeroy	Phil Pomeroy	Album
<b>Metropolis Audio</b>		Contact Kerri Minchin (03) 696 2111	
Dave Graney/Coral Snakes	Tony Cohen	Tony Cohen/Andy Baldwin	Album
The Badloves	Michael Spibey	Doug Roberts/Timmy J	Remix
The Rolling Stones	Chris Kimsey	Mat Thomas/Greg O'Shea	Michael Hutchence Vocal on Rolling Stones song.
Film with the O/B	Bruce Rowland	Robin Gray/Mat Thomas	Soundtrack for 'Lightening Jack'
Paul Kelly	Paul Kelly	Simon Polinski	Album Tracks
Kate Ceberano & Friends	Ern Rose	Ern Rose/Mat Thomas	CD of TV Series
Baby Animals	Take 40 Aust.	Ern Rose/Mat Thomas	Live with O/B on Take 40 Aust.
<b>Newmarket Music</b>		Contact Studio Manager (03) 329 2877	
Howlin Time	Band/Daniel Desiere	Daniel Desiere	Album
Keith Harnslow		John Ruberto	CD Mastering
Margie Lou Dyer		John Ruberto	Demo
Allan Leake		Robert Dillon	Mixdown
Gonwanaland		John Ruberto	CD Mastering
Zydeco Jump		Robert Dillon	Mixdown
The Giants	Band/Daniel Desiere	Daniel Desiere	Album
Zydeco Jump		Robert Dillon	CD Mastering
<b>Platinum Aust. P/L</b>		Contact Gary Moorhead (03) 827 7483	
Hunters & Collectors	Mark Freegard	Kalju Tonuma	Album Mix
Underground Lovers	Simon Polinski	Chris Corr	Album Mix
Broon	Mark Forrester	M.Forrester/Kalju Tonuma	Mixing
The Sharp	Rick Will/Peter Farnam	Rick Will/Kalju Tonuma	Album,
Sonny Morgan		Chris Corr	Album Mixes



YOUR MUSIC IS SAFE WITH US



## HOW TO LIST YOUR STUDIO:

1. Deadline is ALWAYS the 15th of the month before publication. We reserve the right to select suitable material. No cost!
2. Mail or Fax the information to us, you do not need a specific form, but you do need to follow the format of the guide, which is obvious - have a look.
3. We must limit listings to eight or less separate artists.
4. Please note your studio NAME, phone number, state and your contact details so we may check anything odd.
5. If we have any doubts we will contact you around the 20th of the month. It's FREE!
6. Questions? Verification? Call Elaine on (02) 876-3530 (BH).

*Send to: Connections, BASF Guide, PO Box 439, Epping 2121, or Fax: (02) 876-5715.*

ARTIST	PRODUCER	ENGINEER/S	NOTES
<b>Sing Sing Studio</b>		Contact Kaj Dahlistrom (03) 428 462224/48 Track	Sony Digital Studio
Sunday Kind	Dan Friedman	Chris Thompson	Mixing Album
Albare	Band	Tony Esple	Mixing Album
The Outlaws	The Band	Michael Letho	Mixing Album
Colin Hay	Colin Hay	Phil Butson	Rec. & Mixing Album
Maurice	Trevor Reading	Trevor Reading	Recording Album
<b>Studio 52</b>		Contact Paul Higgins (03) 417 7707 16,	24 Track
Peter Cupples	Peter Cupples	Trevor Carter	Album
Indian	Band	Trevor Carter	Album
Geoff Achison	Jaques	Trevor Carter	Album
<b>The Jam Tin Sound Studio</b>		Contact Mark McCormack (03) 583 2341 16 Track	
Sulcety	Band	Mark McCormack	Demos
The Heat	Band	Mark McCormack	Demos
<b>South Australia</b>			
<b>Mixmaster Productions</b>		Studio Manager (08) 278 8506	
Miltons	Miltons	M. Turrell	Album
Jeff Lang	L. Karski	M. Wordley	Mix Album
Lizard Train	Lizard Train	M. Wordley	Demo - Pre Prod.
All Flight Crew Are Dead	Band	M. Wordley	E.P.
Numb Skulls	Band/M. Wordley	M. Wordley	E.P.
Buckley's Chance	Band	M. Wordley	Album
Before You Were Blonde	M. Turrell	M. Turrell	E.P.
<b>Western Australia</b>			
<b>Bonsai Recording Studio</b>		Contact Tom Thorpe (09) 349 60	
P.M.F.M. Morning Crew	Tom Thorpe	Tom Thorpe	Jingles
Andrew Breen	Tom Thorpe	Tom Thorpe	Demo
Aurora	Tom Thorpe	Tom Thorpe	CD
<b>Planet Sound Studios</b>		Contact John Villani & Kim (09) 382 2211 48/32/24 Track	
Empire	Band	John Villani/Les Williams	Album
The Faces	John Villani/Band	Les Williams/John Villani	Single
Richard Wally		Les Williams	Album
Off The Planet	John Villani	John Villani	Mix - Single
Lloyd Mosel		Les Williams	Album
<b>Tropo Sound</b>		Contact Mick Connolly (091) 92 2394 24 Track	
Gulinginunga	Bill Hart	James Edwards	Album
Wayne Barker	Wayne Barker	Solo Album	
Frank Baguley		Frank Baguley	Solo Album
The Insiders		James Edwards	Album
Footprince	Daryl Newton	James Edwards	Album

**YOUR MUSIC IS SAFE WITH US**



**BASF**

# APHEX Four Channel Rack Packs



**APHEX Easyrider**, a four channel intelligent compressor that varies attack and release characteristics dependent on the texture of the input signal. Just dial in the amount of gain reduction, choose fast or slow time constants and adjust for output gain - it's that simple.

**APHEX Logic Assisted Gate**, a four channel fully parametric noise gate with ultraclean audio path and click free performance. Logic assisted detector circuits ensure absolutely positive and consistent operation, and allow the user to quickly and easily find the right threshold.

Call **EAST COAST AUDIO** now for the name and location of your nearest APHEX stockist. Phone (03) 428 9797 or 018 381 481 or Fax (03) 427 9898.



Broadcast Technology Pty Ltd. A.C.N. 005 689 752. RAY WELCH ADV.

Write in Reader Service number: 136

*People have been known to call it*

**The**  
**Most Stolen**  
**MUSIC** Publication **In The**  
**INDUSTRY**

*The Yellow Pages  
Of The Pacific Rim  
Music Business*

Includes: Australia,  
New Zealand, Japan,  
China, Hong Kong,  
Singapore, Malaysia,  
Indonesia, Korea,  
Taiwan, Philippines  
and Thailand

12th edition, January 1994  
**Australasian Music  
Industry Directory**

- 5000 company listings
- 3000 individual contact names
- 53 categories and sections
- 323 pages

Please send me \_\_\_\_\_ copy(ies) of The Australasian Music Industry Directory.

Name \_\_\_\_\_

Address \_\_\_\_\_

Postcode \_\_\_\_\_

Phone ( ) \_\_\_\_\_ Fax ( ) \_\_\_\_\_

Enclosing Cheque or  Bill Credit Card # \_\_\_\_\_

Bankcard  VISA  Mastercard expiry date \_\_\_\_\_

(Make payable to MUSIC DIRECTORY)

Mail with payment or credit card orders can be faxed to (02) 211 5938

Phone inquiries to Alix or Alison on (02) 212-6677

Next edition July '94. Are you listed yet? Deadline April 15 for listing forms.

By Mail Order \$15 from:

**IMMEDIA!**

3 Rose St.,

Chippendale NSW 2008.

Bank Cheque or Postal Money Order  
(Credit Cards—BankCard, VISA, Mastercard)

**Professional Audio, Musical Instrument, Lighting & Production Distributors & Retail/Hire,  
Recording Studios, Venues, Record Companies, Publishers, Managers, Booking Agents,  
Promoters, Concert Production, Music Print Media, Radio, Television, Music Video, Artists,  
Consultants & Special Services, Special Events & Festivals, College Bookings and many more.**

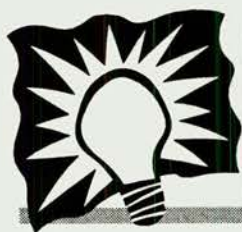

# LIGHTING MONTHLY

## LAVA is now Show Technology

"We know how easy it's not", quipped Rod Salmon in the board room at Show Technology, while partner Emmanuel Ziino considered his new role as managing director. "At Emmanuel's age he's full of energy - while I'm full of something else!" The duo are meeting with me on the second official day of trading at their new company, the result of the merger of LAVA (Lights, Audio, Video Australia) & Australian DJ Supply Co.

For 1994 Show Technology is a big news startup, with impressive new premises at Rydalmere in Sydney's Central Western precinct, a small suburb now coincidentally home to Bose, Freedman and several hire firms active in the sound and lighting market.

Previous to now, LAVA mainly distributed Clay Paky and Martin 'intelligent' lighting products, while Australian DJ Supply Co shipped in mainly Taiwanese effects lighting, Par Cans, Smoke machines and some disco sound gear. With clear delineation, the two product portfolios sit comfortably together, despite continual industry speculation that Martin and Clay Paky products clash.

Emmanuel started Australian DJ Supply Co with his wife Gina, who now works with him at Show Technology. The merger with LAVA is something they say they all wanted to do, not something they were forced to do, because A.D.J. Supply Co was going gang busters, says Emmanuel. "We introduced a 12 month warranty and it worked out as we expected" he says, countering the cynics.

Show Technology is clearly going to either grab more existing market share, or better still, ride the projected growth in the economy many hope has already started. Rod Salmon is ardent the Olympics are good for business, in fact he must have known we had won them well before the rest of the world, because he had bought a stake in the Wentworth Hotel at Homebush, near the games site, just days before the announcement last September! But back to the story ....

"I think I can sell 50% more in



Rod Salmon & Emmanuel Ziino

the (existing) market by being better at it", says Rod Salmon. Better means the step up from LAVA to Show Technology, where service, support, backup and training are more important than ever.

The three story building is being fitted out with a training and display area, a 'shop front', and downstairs a decent sized service department and warehouse. Up top are the offices where already a respectable number of staff work, (continued on page 58)

## Jands Stage 12/24

The Stage 12 and Stage 24 lighting control consoles caught Jands napping when released - because demand proved insatiable.

Intended for local markets, the two preset 'mini memory' boards became a hot seller on the export market, much to the pleasure of Jands boss, Paul Mulholland.

With two grab faders acting as phantom third and fourth presets, the consoles are finding use with both entry level users - like schools - and hire firms who extend the pre-set facilities of their Jands Event and ESPII consoles.

DMX compatibility provides the ability to link consoles, moving



lights and scrollers by means of a simple, common data path.

In addition, a Wide Mode function doubles the available control channels, and a chase function can be assigned to any or all channels.

Both consoles (12 & 24) have a 2 year warranty. For info call Jands (02) 516-3622.

Francis Taylor opens shop on Sydney's North Side

### NEW LIGHTING OUTLET

During Strand's darkest days, Francis Taylor kept on being a nice person, while many Strand people didn't, and now after threatening to do so for at least 10 years, she has opened her own outlet. STAGE & STUDIO is a partnership with Chris Roarty, another one time Strand person, and it will continue to service the market Francis has built up, in theatre, schools, film and TV. They do Rosco, ProLite, Coemar DeSisti and Jands, along with every kind of lamp and LX snazpad possible. Call them, and say 'good move!' (02) 439-8188.

## BUYERS GUIDE

### FLOODLIGHTS

Lighting prices always EX TAX

**Strand Lighting** from Bytecrafft Pty Ltd. (03) 587 2555

**Miniflood** \$171.00 . Single unit symmetrical refl 250w

**Nocturne 500** \$228.00 . Wide-angle, general purpose single unit floodlight 500w

**Nocturne 1000** \$272.00 Wide-angle general purpose single unit floodlight.1000w

**Coda 530/1 Cyclight** \$211.00 Wide angle single unit asymmetric flood light.500w

**Coda 500/3 Cyclight** \$527.00 3 Compartment asymmetric floodlight 500w

**Coda 500/4 Cyclight** \$681 4 Compartment asymmetric floodlight 500w

**Coda 1000 Cyclight** \$277.00 Wide angle single unit asymmetric floodlight.1000w

**Orion** single unit Groundrow \$625.00 Single compartment floor standing cyc. light 625/1000/1250w

**Orion 4** rigid groundrow \$2353 4 Way rigid floor standing cyc. light. 625/1000/1250

**Orion 4** ringed groundrow \$2714 4 way ringed floor standing cyc. light. 625/1000/1250 .

**Mini Iris** Cyclight \$475 Single compartment compact cyc. light 625/1000/1250 .

**Iris 1** M.O. Cyclight \$757.00 Top mounting single compartment cyclight 625/1000/1250 .

**Iris 2** P.O. Cyclight \$1577.00 . Double compartment cyc. light in vertical or horizontal. 625/1000/1250

**Iris 3** P.O. Cyclight \$2107.00 Three compartment horizontal cyc. light. 625/1000/1250 .

**Iris 4** P.C. Cyclight \$2226.00 . Four compartment Cyc. light. 625/1000/1250 .

#### SELECON New Zealand

**CYC500** \$245.00 Suitable for top or bottom of 7m Cyc. Halogen 500/800w.

**CYC500/3** \$610.00 3 Colour unit construction for top or bottom 7m



## SALES, PR & TALK

• **Selecon** have been very conservative with the **Arena Zoomspot** output figures quoted the brochure. Factory tests indicate a consistent 700,000+ cd being produced by the 2500 Narrow.

• Channel 9 in Sydney recently tried out the Selecon **Arena Zoomspot 2000M** (14-32°) at a 10m throw with a venetian blind gobo. They measured 150 ft candles (1614 lux) with a variation of less than 1:1.5 across the beam.

• The Victorian Arts Centre purchased 30 **Arena** high performance 2.0kW fresnels after comparison testing against someone else's. Selecon say their fresnel kicked the butt of a competitive 2.5kw unit. And the Adelaide Festival Centre have ordered 80 Zoomspot 1200 18/34° models.

• **BYTECRAFT** are rumoured to have cut a deal with LSD, the UK based manufacturer of high tech lighting for the touring market. Word has it that the **ICON** moving light system first seen here on the Madonna and U2 dates has remained in the country. If so, this is an interesting move for the Melbourne firm, who are strong in the export market.

• Channel 7 in Brisbane have purchased a **Compulight Compact Animator** console to drive their Super Scans. David Lee tested various boards, in the end **LASER's** Phil Hanson won the order for Coemar deSisti Australia.

• **Rohan Turner** at Ch.9 in Melb, bought Microlux 1000 lighting plot software, "I'll never do it by hand again" he said. Do what?

## Product Bits

• **JEM** now have a **WATER CRACKER**, and it aint something you serve with a cheeseboard. Using a water based fluid, mist is distributed through specially developed symphonic nozzles. They are, of course, ideal for making light beams visible but where you do not wish to obscure visibility. The Model 1200 costs \$8800 INC TAX, and cheaper model 300 and 600 machines are due soon. *Call Show Technology (02) 816-4444.*

• We used to sneak the domestic Rota Breeze fan into the truck before a tour, to distribute the smoke from the Rosco fogger. Now days you need real industrial equipment, so C.D.A. would like to offer the **RE FAN**, a 12kg, 275mm blade mother that will BLOW and BLAST on demand. It's got variable speed and mounts on a stand or on the floor. \$2850 ex tax.

## Buyers Guide Floodlights (continued)

Cyc. Halogen 500/800w.  
**CYC500/4** \$735.00 4 Colour unit as above. Halogen 500/800w.  
**FLOOD500** \$258.00 Symmetrical Flood C/W Barndoors. 500/800w.  
**HALIDE FLOOD** \$400.00 Metal Halide Flood Uplighter C/W safety glass & barndoors. Metal Halide 150w.

**COEMAR DE SISTI (03) 467 8666**  
**Glotto 1** - Manual Operated \$550.00 C/w wire guard, col. frame. 1000/1250w.  
**Glotto 2** - Manual Operated - Vertical \$1040.00 - . C/w wire guard, col. frame 1000/1250w  
**Glotto 2** - Manual Operated - Horizontal \$1040 ex. tax. C/w wire guard, col. frame 1000/1250w.  
**Glotto 3** - Manual Operated - Horizontal \$1520.00 . C/w wire guard, col. frame 1000/1250w.  
**Glotto 4** Manual Operated \$2020 . C/w wire guard, col. frame 1000/1250w  
**Glotto 4** Manual Operated - \$2020.00 .Horizontal C/w wire guard, col. frame 1000/1250w.  
**Glotto 1** - Pole Operated \$780.00 .

# CLS

## CONCERT LIGHTING SYSTEMS

AUSTRALIA PTY. LTD.

# 18000ft<sup>2</sup> of Stage Lighting Equipment for HIRE and SALE.

Black Drapes  
Grey Drapes  
Scrims  
Lycian Follow Spots  
Thomas Cyc Units  
Control Consoles  
Mains Power Cables  
Emulators  
Effects Projectors  
Gobo Rotators  
Oil Crackers  
Dry Ice Machines  
Smoke Machines  
CM Chain Hoists  
Standard and Extra Large Colour Scrollers

Moving Lights  
Dimming Systems  
Par Cans  
Theatre Spotlights  
Power Distribution  
Rigging Equipment  
Steel and Alloy Truss  
Clearcom Intercom  
400W UV Floods  
Turbo Fans  
Avab Consoles  
Color Faders  
Terra Strobes  
LeMaitre Pyro's

**Concert Lighting Systems Australia Pty. Ltd.**  
**Head Office: 282 Normanby Road**  
**Port Melbourne, Victoria 3207**  
**Tel: (61-3) 646 8444 Fax: (61-3) 646 8555**

ACN 005 422 319

CLS/CONN/07

## Product Bits

# STATUS CUE IS NEW

• You know when you try to hang a big fixture—like a moving light—with the yoke at right angles to the truss? No matter how much brute you apply to the hook clamp, the whole lot slowly sinks down to normal hanging position. You need a **DOUGHTY SUPER CLAMP**. Call C.D.A. (03)467-3666.

• Selecon's new MDR 1200 short throw follow spot is now available. Using a shortened version of the long-throw body work, the MSR "short" offers 10° to 15° zoom beam angle, in-built fader, iris, gobo slot, cutter and par size colour changer. Output is extremely good, say the Selecon-ners, at 1000 lux at 38m. It's available from 22 Selecon dealers, Australia wide.

• Still no word on the fate of Kupo product distribution across Australia - still up for grabs, we think, after Kupo Taiwan terminated Kupo Australia recently.

High End Systems new Status Cue console links to your 486PC to control Trackspots, Intellabeams and the new CyberLight fixture simultaneously. Interestingly, once you have the Status Cue Link Card installed in your PC, you don't have to have the console (pictured below) hooked up. The Cue Link Card handles 64 fixtures. Extra cards can be slotted into your PC

for extra fixtures. A bi-directional link gives diagnostic information to the operator.

Status Cue allows the LD to build a palette of scenes or position memories, useable as references for preset focus. 128 palettes are available, each containing up to 4871 scenes.

More details from G.U.V.T., call Noel Bourne: (07) 358-5022.

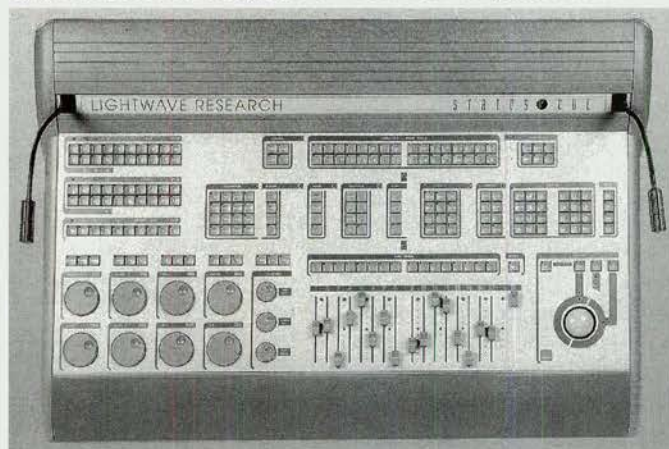

## Buyers Guide Floodlights (continued)

C/w wire guard, col. frame 1000/1250w

**Giotto 2** - Pole Operated - Vertical \$1270.00 . C/w wire guard, col. frame. 1000/1250w.

**Giotto 2** - Pole Operated - Horizontal \$1270.00 . C/w wire guard, col. frame 1000/1250w

**Giotto 3** - Pole Operated - Horizontal \$1800.00 C/w wire guard, col. frame 1000/1250w

**Giotto 4** Pole Operated \$2300.00 C/w wire guard, col. frame 1000/1250w

**Giotto 4** Pole Operated - Horizontal \$2300.00 . C/w wire guard, col. frame 1000/1250w.

**Duccio 1** \$496.00 Adjustable Grandrow single unit 100/1250w.

**Duccio 2** \$995.00 Adjustable groundrow two compartment 1000/1250w.

**Duccio 3** \$1490.00 . Adjustable groundrow three compartment. 1000/1250w.

**Duccio 4** \$1990.00 . Adjustable Groundrow four compartment. 1000/1250w.

**Ribalta 1** 300/500AL \$129.00 . Single cyc./work light 300/500w.

**Ribalta 3** 300/500 AL \$246.00 .

# The light for the lighter budget

It could be the budget. Or that you simply don't need the world leading performance of our 1200 Fresnel and P.C. Whatever the reason, take a look at our new low priced range of Compact 6 luminaires. They're performing minor miracles on stage, and on the balance sheet.

## COMPACT PC

Adjustable beam from 5° to 60°.

Crisper edge beam giving good control for area and high lighting.

Weight 5.4kg



## COMPACT F

Adjustable beam from

7° to 50°. Soft edged cone of light easily blended together to provide even illumination.

Weight 4.56kg



**100%  
PERFORMANCE  
AT 65%  
OF THE PRICE**

Comparative Performance Figures as Published in Manufacturers Literature

	Beam Angle	Peak Candela		Peak Candela		Lens Size
		Spot	Flood	Spot	Flood	
Fresnels						
Compact 6	7-56°	165,600	17,640	120,000	13,680	150mm/6"
Selecon 1200	7-56°	228,939	27,158	126,000	14,040	175mm/7"
Strand Cantata	7-7-50°	123,250	10,900			150mm/6"
CCT Starlette	6-57°	156,000	17,750	136,200	12,500	150mm/6"
Teatro Tratto	6-35°	138,500	24,600	132,400	21,000	150mm/6"
Teatro Spazio	8.5-50°			116,200	13,600	150mm/6"
P.C.'s						
Compact 6	5-60°	306,000	15,840	205,200	10,000	150mm/6"
Selecon 1200	4.5-60°	342,000	14,220	226,800	10,000	175mm/7"
Strand Cantata	4.2-49°	208,000	14,300			150mm/6"
CCT Starlette	7-36°	152,500	18,300	127,000	13,250	150mm/6"

TAS KW McCulloch (Hobart) Ph: 002-288373 KW McCulloch (Launceston) Ph: 003-431 034 NT Top Ends Sounds Ph: 0-89-81 7744

NSW Herkes Ph: 0-2-319 3133 MacSound Ph: 0-6-778 4096

VIC LSC Ph: 0-3-561 5255 Three Arts Ph: 0-3-818 0397

QLAND East Coast Lighting Ph: 0-7-252 9583

SA Osmonds Ph: 0-8-410 1111 ACT Topstage Ph: 0-6-280 571C

WA Kosmic Ph: 0-9-242 3844 Stagecraft Ph: 0-9-227 900C

# SELECON

PH: 64-9-360 1718, FAX: 64-9-360 1719

Write in Reader Service number: 146



## The IDIOT

While last month I revealed How To Light a Professional Theatre Production (*without prior experience*), I must confess it proved a lot harder to work in the psychedelic era. In 1971 Sydney had The Arts Factory, and Melbourne the T. F. Much Ballroom, where new and weird lighting was born.

I hung about at The Arts Factory where bands like Taman Shud, Tully and Company Caine were staple fare in between some more commercial flirtations like Carson, Daddy Cool and Billy Thorpe's Aztecs. The common theme for all was the house lightshow, driven by an acid head couple I'll call Mike and MaryAnne, and a guy I regard as a genius, Eddie Van Der Madden.

Eddie lived in a large room in a run down boarding house, absolutely crammed full of paraphernalia electrical - anything that might have a future use in lighting lived right there in that room with Eddie, and I include heaps of old valve operated army disposal stuff, even an old photocopier.

Each Thursday night Eddie would debut his latest invention, the best was The Meltdown Machine, a really bright oversized projector in which a hand painted slide would melt, then catch fire.

This was the stuff of future shock, six or seven stoned 'heads' would operate overhead projectors, each masked off onto part of the cyclorama above the band, who would usually play in the dark, or at best partially dimly lit. Two pyrex dishes were used, along with a water based and an oil based dye. Weird colourful liquid throbbing amoebas would pulse in time with the music, then the operator would drop another tab of acid and after a while become dysfunc-

tional, whereupon Eddie would switch off their projector.

Up at Selby Scientific Supplies the counter clerk, Mrs. Millington, got used to wild eyed hairy types getting off the bus to buy more pyrex dishes. Later on she had to cope with emissaries from Jeff Crossiers Magic Circus and even a young Jim Murray, the famous Sherbet Lighting Guru, who all bought powdered magnesium from her for pyrotechnic enhancement. But I digress, and old Mrs. Millington has long since retired.

Eddie invented the Kaleidoscope Machine, which was the first hand painted effects wheel projecting down a kaleidoscope. Then there was the Fish Tank Machine, which featured a little glass tank in the projector gate, fed bubbles by an aquarium pump. It wasn't called the Fish Tank Machine at first, but some head dropped some tadpoles in while Eddie wasn't looking. A gentle and sensitive man, Eddie had tears in his eyes as 200 hippies watched incredulous the death throes of the poor larvae, trashing about in a mixture of oil and water, bubbling along and superheated because Eddie loved taking out the heat filter on his projectors.

So to set the record straight, this was the beginning of the psychedelic lightshow, and the traditional elements of a commercial 'lightshow', namely the mirrorball, colour wheel and strobe, were all rejected by Eddie and Co. Even the mind expanding U.V. tube was banished to the adjoining 'quiet' hall. Funny enough, Eddie didn't do drugs at all, he was a purist

In case you do think about history, bands still didn't bother with lights until about 1974, taking whatever was supplied. Yes, the promoter had to hire a 'lightshow', separate to the band.

But that's another story!

## Peter Kemp

### DIMMING OVER THE YEARS

My early days in dimming were with Strand Electric, where I was employed as an Electrical apprentice. In those days, Strand was manufacturing electronic thyristor dimmers, however there were many earlier dimmers in operation that we serviced. Thus I was introduced to the Resistance Slider Dimmer being the Junior 8, not a slider as we know it today but a slider dimmer wound on heavy slate former. These dimmers had a dimmer knob for operation which one could use a wooden rod to control multiple dimmers at the same time. (*Grind, scrape! -Ed*)

The other old style dimmer that I remember servicing is the Strand CD system that were basically reactor dimmers with electro-mechanical servo's. These systems were in many prominent theatres and, in fact, Startec in Melbourne have a full restored system sitting in their showroom. If you have never seen this type of system then it is well worth a look.

Electronic dimmers certainly changed things. Today's main type of dimmers have not really changed in great detail from the early days of Thyristor dimmers, though certainly computer technology has added greatly to today's dimmers.

There is one company I know of in the USA, Entertainment Technology, who have approached dimmers in a totally different way, with their Intelligent Power System, which departs from the conventional approach to dimming in two ways: each dimmer has its own micro-controller that controls the timing for the gating of Insulated-Gate Bipolar Transistors IGBT's instead of an SCR/ Thyristor, and

## Buyers Guide Floodlights (*continued*)

Three unit cyc./work light.300/500w.  
Ribalta 6 300/500 AL \$423.00 .  
Six unit cyc./work light 300/500w.  
Sequenza 1 500 AL/S \$365.00 .  
Single, or Interlocking multiple, symmetrical Cyc. light. (Barndoor Accessory available.) 500w.  
Sequenza 1 500 AL/A \$353.00 .  
Single or Interlocking multiple, asymmetrical Cyc. light (Barndoor accessory available) 500w.  
Sequenza 1 1000/1250 AL/S \$394.00 . Single or interlocking multiple, symmetrical Cyc. light (Barndoor accessory available) 1000/1250w.  
Sequenza 1 1000/1250 AL/A \$381.00 . Single or interlocking multiple, Asymmetrical Cyc. light. (Barndoor Accessory available) 1000/1250w.

**Teatro** from Lightmoves Technologies (02) 560 0000  
Diluvio A1000 - Modular \$330.00 (Prices include lamp) 1000/1250w  
Diluvio A500 - Modular \$290.00 500/300w  
Diluvio S1000 - Modular \$400.00 1000/1250w  
Diluvio S500 - Modular \$380.00 K1/K9 500/300  
Riga 1 \$140.00 500/300w  
Riga 3 - 3 Way \$320.00 500/300w  
Riga 4 - 4 Way \$460.00 500/300w  
Worklight \$130.00 500/300w

\*\*\*\*  
**NEXT MONTH:  
RIGGING, TRUSSING,  
FLYING!**

the system uses a distributed dimming scheme.

The use of the IGBT's and Entertainment Technology's other tricks make their system extremely quiet both acoustically and electrically with no choke.

The other feature, a distributed dimming system, seems to be becoming more common today. More on this later.

•Peter Kemp is boss at Coemar DeSisti (Aust). (03) 467-8666.

**Lots  
Of  
Watts**

**Everything** in Sound & Lighting: Hire, Sales, Installations and Service

Lots Of Watts Pty Ltd (ACN 055008314)

47 Brodie Street Rydalmere NSW 2116 Call (02) 638-0302, Fax (02) 638-0331

# BUYERS GUIDE

## COLOUR FILTERS

Lighting prices always EX TAX

ARRI from the John Barry Group (02) 439 6955

Full range of Polyester-based filters including 23 Correction Filters, 9C Colour Effects Filters & 6 Reflectors. Rolls from \$70.00 Sheets from \$12. Colour numbering system similar to LEE.

**CORRECTION FILTERS** Rolls 25' x 4' (7.6 x 1.2m)

**DIFFUSION FILTERS** Folis 25' x 4' (7.6 x 1.2m)

**COLOUR EFFECTS FILTERS** Rolls 25' x 4' (7.6 x 1.2m)

**REFLECTORS & ACCESSORIES** Rolls 25' x 52' (7.6 x 1.3m)

**SHEETS** 24" x 21" (minimum order 25 per colour)

Procolour available from JANDE (02) 516 3622.

Colour effects filters flame retardec polyester twin dye, coated for longer life. Colour numbering system similar to LEE.

**CORRECTION FILTERS**

Rolls only 7.625m x 1.22m Spur Filter 914mm x 7.623m

Effects Colour Rolls @ \$132.00  
Correction Media @ \$132.00, Spur Filter @ \$90.00, Effects Colour Sheets @ \$6.20

**COLOUR EFFECTS FILTERS**  
**SHEETS** 610mm x 533mm Rolls 7.625m x 1.22m

**Lightwave Research U.S.A.** from Greater Union Village Technology Noel Bourne (NZ Stuart Baker) 006 773 187 (NZ 098 309 6135)

Dichroic Filters, high efficiency colour medium, available in a large range of industry standard paper sizes, colours (inc. colour correctors), and supplied either fitted to safety frame screen or as filter only. P.O.A. due to large range and other variables such as tolerance range i.e. 1/-5, 10 or 15 nanometers.

**ROSCO** Australia P/L (02) 906 6262 Ian Baseby

**Supergel** is a range of 111 theatre effect colours and light diffusion filters of high temperature, non-flammable, body coloured polycarbonate, sealed between two microscopically thin layers of clear film to minimize dye migration and maximize the effective life of the colour filter on high temperature lights. Application sheets are available free from Rosco dealers. Available in sheets: 50cm x 60cm

Colour numbering - clear as mud! Actually, it's simple. LEE numbering and colour descriptions are used by ARRI, ProColour and Rosco's E Colour, all of which are SIMILAR in colour to LEE. SuperGel has/is unique, with different numbers.

## LEE Filters Number System

002	Rose Pink	036	Medium Pink	105	Orange
007	Pale Yellow	052	Light Lavender	108	English Rose
010	Medium Yellow	061	Mist Blue	111	Dark Pink
017	Surprise Peach	079	Just Blue	116	Medium Blue Green
021	Gold Amber	089	Moss Green	119	Dark Blue
025	Sunset Red	101	Yellow	122	Fern Green
035	Light Pink	104	Deep Amber	127	Smokey Pink
048	Rose Purple	107	Light Rose	130	Clear
058	Lavender	110	Middle Rose	134	Golden Amber
068	Sky Blue	115	Peacock Blue	137	Special Lavender
088	Lime Green	118	Light Blue	140	Summer Blue
100	Spring Yellow	121	Lee Green	143	Pale Navy Blue
103	Straw	126	Mauve	148	Bright Rose
106	Primary Red	129	Heavy Frost	153	Pale Salmon
109	Light Salmon	132	Medium Blue	157	Pink
113	Magenta	136	Pale Lavender	161	Slate Blue
117	Steel Blue	139	Primary Green	165	Daylight Blue
120	Deep Blue	142	Pale Violet	170	Deep Lavender
124	Dark Green	147	Apricot	176	Loving Amber
128	Bright Pink	152	Pale Gold	181	Congo Blue
131	Marine Blue	156	Chocolate	184	Cosmetic Peach
135	Deep Golden Amber	159	No Colour Straw	187	Cosmetic Rouge
138	Pale Green	164	Flame Red	188	Cosmetic Highlight
141	Bright Blue	169	Lilac Tint	191	Cosmetic Aqua Blue
144	No Colour Blue	174	Dark Steel Blue	194	Surprise Pink
151	Gold Tint	180	Dark Lavender	197	Alice Blue
154	Pale Rose	183	Moonlight Blue	332	Special Rose Pink
158	Deep Orange	186	Cosmetic Silver Rose	353	Lighter Blue
162	Bastard Amber	004	Medium Bastard Amber	189	Cosmetic Silver Moss
166	Pale Red	009	Pale Amber Gold	192	Flesh Pink
172	Lagoon Blue	015	Deep Straw	195	Zenith Blue
179	Chrome Orange	020	Medium Amber	198	Palace Blue
182	Light Red	024	Scarlet	343	Special Medium Lavender
185	Cosmetic Burgundy	027	Medium Red	354	Special Steel Blue
003	Lavender Tint	046	Dark Magenta	190	Cosmetic Emerald
008	Dark Salmon	053	Paler Lavender	193	Rosy Amber
013	Straw Tint	063	Pale Blue	196	True Blue
019	Fire	085	Deeper Blue	328	Follies Pink
022	Dark Amber	090	Dark Yellow Green	344	Violet
026	Bright Red	102	Light Amber	363	Special Medium Blue

## Rosco Supergel Number System

The swatchbook we have doesn't show the first number "1"

1000	Clear	1045	Rose	1081	Urban Blue
1001	Light Bastard Amber	1046	Magenta	1082	Surprise Blue
1003	Dark Bastard Amber	1048	Rose Purple	1382	Congo Blue
1004	Medium Bastard Amber	1049	Medium Purple	1083	Medium Blue
1304	Pale Apricot	1050	Mauve	1383	Sapphire Blue
1005	Rose Tint	1351	Lavender Mist	1084	Zephyr Blue
1305	Rose Gold	1052	Light Lavender	1085	Deep Blue
1006	No Colour Straw	1053	Pale Lavender	1385	Royal Blue
1007	Pale Yellow	1054	Special Lavender	1086	Pea Green
1009	Pale Amber Gold	1055	Lilac	1388	Gaslight Green
1010	Medium Yellow	1355	Pale Violet	1089	Moss Green
1011	Light Straw	1056	Gypsy Lavender	1389	Chroma Green
1312	Canary	1356	Middle Lavender	1090	Dark Yellow Green
1013	Straw Tint	1057	Lavender	1094	Kelly Green
1014	Medium Straw	1357	Royal Lavender	1095	Medium Blue Green
1015	Deep Straw	1058	Deep Lavender	1096	Lime
1317	Apricot	1358	Rose Indigo	1398	Neutral Grey
1019	Fire	1359	Medium Violet	1100	Frost
1020	Medium Amber	1061	Mist Blue	1101	Light Frost
1021	Golden Amber	1063	Pale Blue	1104	Tough Silk
1022	Deep Amber	1064	Light Steel Blue	1113	Matte Silk
1023	Orange	1065	Daylight Blue	1114	Hamburg Frost
1024	Scarlet	1066	Cool Blue	1119	Light Hamburg Frost
1025	Orange Red	1067	Light Sky Blue	1120	Red Diffusion
1026	Light Red	1367	Slate Blue	1121	Blue Diffusion
1027	Medium Red	1068	Sky Blue	1122	Green Diffusion
1030	Light Salmon Pink	1069	Brilliant Blue	1123	Amber Diffusion
1031	Salmon Pink	1070	Nile Blue	1124	Red Cyc Silk
1032	Medium Salmon Pink	1370	Italian Blue	1125	Blue Cyc Silk
1033	No Colour Pink	1071	Sea Blue	1126	Green Cyc Silk
1035	Light Pink	1371	Theatre Booster#1	1127	Amber Cyc Silk
1036	Medium Pink	1072	Azure Blue	1128	Magenta Silk
1337	True Pink	1372	Theatre Booster#2	1129	Sky Blue Silk
1038	Light Rose	1073	Peacock Blue	1130	Medium Blue Green Silk
1339	Broadway Pink	1373	Theatre Booster#3	1130	Medium Blue Green Silk
1040	Light Salmon	1074	Night Blue	1131	Medium Amber Silk
1342	Rose Pink	1076	Light Green Blue	1150	Hamburg Rose
1043	Deep Pink	1078	Trudy Blue	1151	Hamburg Lavender
1343	Neon Pink	1079	Bright Blue	1152	Hamburg Steel Blue
1344	Follies Pink	1080	Primary Blue	1160	Light Tough Silk

\$10.00 Rolls 60cm x 15.24m \$225.00

Supergel Swatch \$2.00

Designer Colour Selector \$25.00

Sheets 60cm x 50cm (multiples 5 each col) \$10.00

Roll 60cm x 15.24m \$225.00 Add 21 for sheets; 22 for rolls

**COLOUR EFFECTS FILTERS**

**ROSCO E-Colour**

E-Colour is a polyester base coated with specially formulated fade resistant dye and complies with the BS3944 flame resistant standards of Europe. The range consists of 71 colour effects, 24 colour correction for balancing light sources and 15 diffusion filters for controlling shadows and contrast. The numbering and naming system is based on the historic and universal European Cinemoid system. Available in Sheets: 1.4m x 50cm \$16.00 Rolls 1.4m x 7.6m \$130.00. (Numbering similar to LEE number system. -Ed)

**ROSCO Permacolour Filter**

Specially hardened, shatter resistant glass with a vacuum deposited dielectric coating to achieve a high transmission and more vibrant colours than regular 'plastic' filter. Available in 17 decorator colours, are unaffected by harsh weather elements and are guaranteed not to fade making them ideal for indoor and outdoor applications. Available in sizes 50mm x 50mm \$35.00 and 168mm diam. \$150.00.

**ROSCO Cinegel.**

Deep dyed polyester material for controlling, balancing, diffusing, reflecting and colouring light and used by film, photographic and video productions to balance light sources in productions and when recording stage shows. Available in sheets 50cm x 60cm \$8.00 Rolls 1.2m x 7.6m \$125.00.

**ROSCO Thermoshield**

Extends the life of 'plastic' gels when used on MR's or other hot lights, and lessens the deleterious effects of heat on performers and products in TV, theatre, display and architectural lighting. Available in sheets 30cm x 30cm \$50.00 and sheets 50cm x 60cm \$125.00.

**ROSCO UV Shield**

Clear film that allows all visible light to pass but filters out more than 90% of UltraViolet light below 390 nanometers and will significantly reduce fading and maintain colour vibrancy in dyed or printed textiles and papers. Available in sheets 50cm x 60cm \$12.00 Rolls 1.2m x 7.6m \$130.00.

**Lee Filters**, from Mediavision Australia (02) 816 4055 (03) 807 5133 Colour Effect Polyester Filter, Rolls 7.62m x 1.22m (25ft x 4ft) Sheets: 508mm x 1220mm (20" x 48"). See number system this page.



## SHOW TECHNOLOGY (cont)

including a marketing person - all too important in 1994. Macs are networked around the place, which has a good 'vibe', or 'ingredient X' about it.

What's the purpose of the shop front, I ask, and Emmanuel is quick to point out that Show Technology is NOT a retail outlet. "We want people to come here and see what we offer," he says, "and we will certainly sell to them at retail if they really want", finishes off Rod. "But what we'll do in wholesale will set the new standard."

Rod and Emmanuel think the 'information superhighway' is here now, and that business needs to respond better, faster and more accurately to customers. "Martin have a bulletin board, and some of our customers here in Australia access that directly right now", says Rod, "and soon a new wave of products will change the way people do things". The crystal ball at Show Technology is currently tuned to 'colour changer' land.

These are devices that replace traditional, conventional luminaires, and are controlled by DMX without the need for dimmers. Who would ever have thought that

DMX 512, a protocol for the digital control of dimmer racks, could end up spelling a greatly diminishing role for those same dimmers - while controlling lanterns with inbuilt electronics? "Think of it", says Rod, "hang a fixture, plug it in, and daisy chain a DMX lead to each. No dimmer racks!"

Vince Hadad is Technical Support Manager at Show Technology, having been an original at the firm that spawned Australian DJ Supply Co, and he's computer savvy, typical of the kind of staff Show Technology hope to put on the front line. "We build them", says Rod, acknowledging special-

ist knowledge in a tiny niche industry doesn't walk in the door.

"When people have problems it's usually something you sort out over the phone, like a dip-switch problem or a shorting plug not fitted", says Rod. To facilitate this new 'service is everything' credo, the firm has a 1-800 freecall number monitored at all times.

Then there are growing pains and unexpected hiccups that a larger business can create, "I'm just terrified of inter-office memo's", says Rod!

*Show Technology is at 13-15 Bridge Street, Rydalmere NSW, phone (02) 898-1111.*

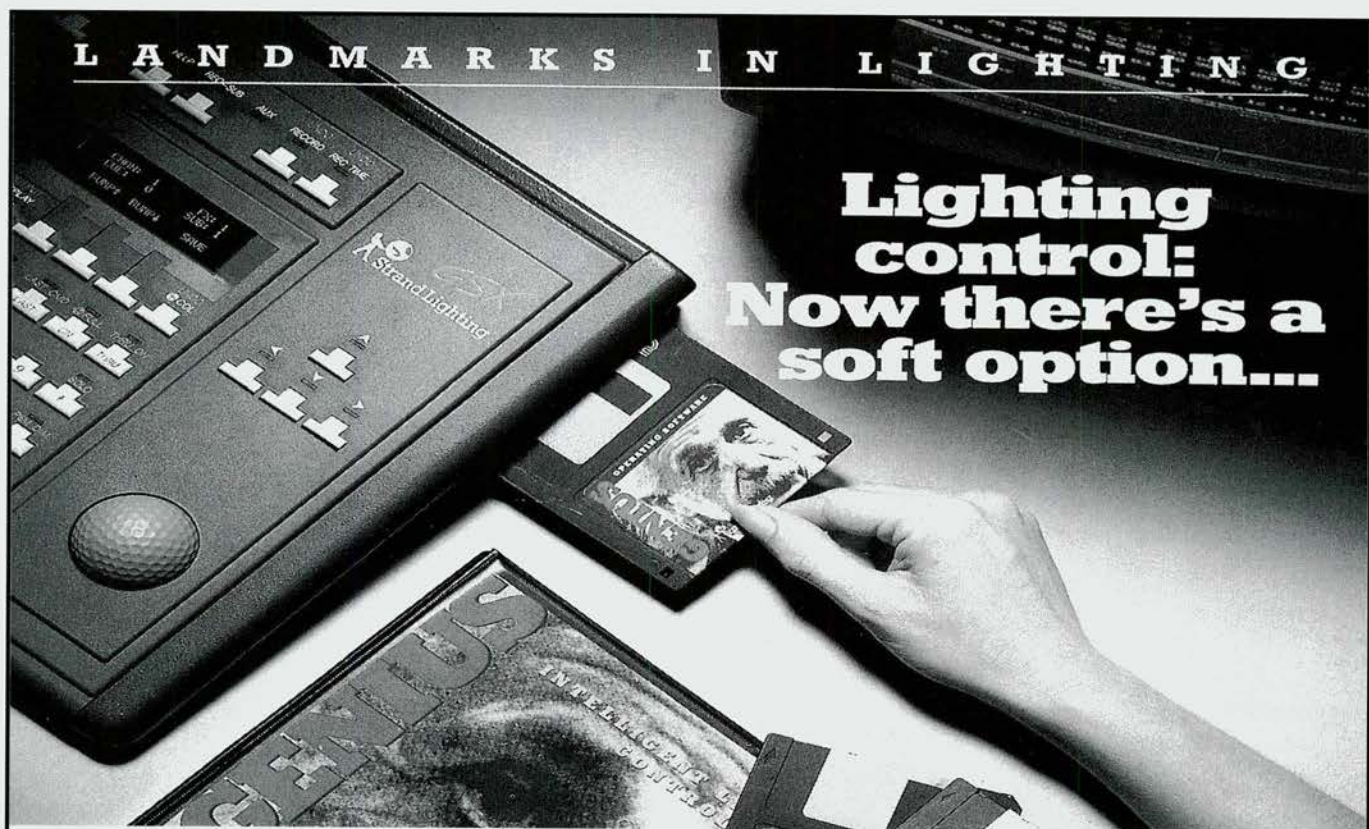

**S**trand's GSX™ console announces a new era in lighting control, offering you the flexibility to choose and upgrade your console software via the integral 3.5" disk drive. Simply select one of the Genius™ foundation applications for 25, 50, 75, 100 or 125 channels, giving full professional functionality, then add Kaleidoscope™ for advanced effects and colour scroller control, and Communique™ adding MIDI, Midi Show Control, DMX in, RS-232 control and more. So when the time comes to

add features or channels, you won't have to replace your desk - just upgrade your software. It's brilliant! Ask for more information [now!](#)



## Strand Lighting

Available soon from

## BYTECRAFT

PTY.LTD

A.C.N. 006 348 054

23 Fonceca Street, Mordialloc, Vic  
Tel (03) 587 2555  
Fax (03) 580 7690

Unit 4, 2 Railway Pde, Lidcombe, NSW  
Tel (02) 646 5999  
Fax (02) 649 4885

24 Cordelia St, South Brisbane, Qld  
Tel (07) 846 3777  
Fax (07) 846 5630



Write in Reader Service number: 155

# CONTRACTING

## EVERY 2ND MONTH

### ZHONG SHAN SCIENCE HIGH TECH FANTASY OPENS 20 AUSSIE'S IN CHINA

Australian expertise is coveted in Asia, where many huge emerging economic forces find local knowledge in pro audio, lighting, video and laser technology scarce.

At presstime Melbourne pyrotechnician Jack Moeller told Connections that the newly opened Zhong Shan Science High Tech Fantasy World in Guan Dong had been commissioned with the aid of a large Australian crew.

According to Jack, several Aussie firms contracted to provide expertise and equipment, including T.C.P. and Laser Vision in Syd-

ney, and Show Tech from Melbourne.

The installation includes four colour lasers, video, audio and special effects, and is controlled by a Spectra Vision controller built by Laser Vision. This provides separate SMPTE, MIDI and DMX switched outputs, and laser scanner information to the whole park. In addition, the controller is accessible via modem from Australia.

The park is apparently modelled on Disney World, but don't tell Walt. Audio gear was all EV, according to Jack.

### 2 NEW AT N.M.S.

New Media Systems (NSW) have expanded their contracting staff with the appointment of two AV systems engineers.

Tim 'Slowhand' Gentile, an A grade sparks, a mean bass player and keen home studio boffin, has many years experience of subcontracting. The nickname was earned on his first day when he cabled and fitted off a lectern mic at a humanly impossible speed and cexterity.

John Tucek, (pronounced Juan-Too-Check), has a background in the field of electronic installations including some fairly unusual communications systems. Although hired for his keyboard abilities, he is handy to have around on site when testing microphone channels during commissioning: 'Say your name again John....'

Both guys automatically join New Media's blues band, "Time Wasters Welcome".

### MEDIA LINK WORKSHOP

Organisers of ENTECH '94 trade show have announced a series of one hour workshops covering contracting topics. Emphasis on Lone Wolf's Media Link technology will draw on recent developments in linking audio, lighting and video systems to a common operating system. The workshops carry a nominal entry charge, entry to ENTECH is free. Held October 6-8, at Sydney Exhibition Centre.

## BUYERS GUIDE

### AUDIO TEST EQUIPMENT

Leaser from AWA Distribution (02) 898 7666

**LAG-126 Audio Signal Generator** \$1359.00 ex tax. The LAG-126 is an audio signal generator designed to supply sine waves having an extra low distortion factor over the frequency range of 5Hz to 500kHz. The output voltage is calibrated in dBm and dBv, and 0.1dB and 10dB steps attenuators ensure that it provides standard output.

**192A 2-Ch. Audio Tester** \$2467.00 ex tax. The 192A is a combination of a wideband audio generator, an attenuator and a wide-band 4C millivolt meter. It is especially useful in testing and servicing audio circuits, monaural and stereo for frequency response and gain characteristics.

**LM-39A Wow & Flutter Meter.** \$1638.00 ex tax. The LM-39A is a direct reading type instrument designed for measurement of wow, flutter and drift characteristics of tape recorders, record players and other such equipment. The effective values, peak to peak values and centre frequency of W & F are indicated on the meter.

**LDM-17 Distortion Meter** \$1926. ex tax, the LDC-171 is a semi-automatic distortion meter that can measure THD in audio amps and comms equipment. It covers the

## PRODUCTS

### ECHO CANCELLER

The AVT-24™ from Sound Control Technologies Inc is a full 24 bit DSP echo canceller designed for integration into audio and video conferencing systems. The 1RU cabinet comes with all options of 2-Wire (Austel approval pending), 4-Wire and VCR ports as well as 3 remote control ports - 2 RS-232 and 1 contact closure. This product has the fastest adaptive algorithm on the market with a minimal dependence on white noise 'training'. A pair of changeover relay contacts are provided to interactively control external equipment. Call New Media Systems, (02) 418 6388.

### BOSE WATERPROOF

The new Bose 151 Environmental speakers are engineered for extremes, handle 80watts and cost \$499 a pair. Size: 155 hi, 231w x 150 deep. 1.8kg weight. Call BOSE (02) 684-1022.

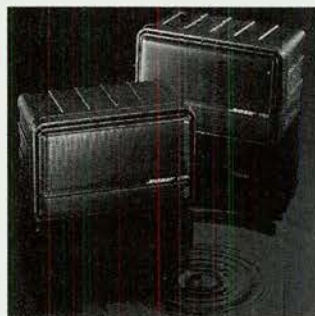

## GRAFTONS

*Dynalite*



THE RIGHT PRODUCTS

LIGHTS

## GRAFTONS

Sydney's largest  
AM Rental  
Department

THE RIGHT CHOICE

SOUND

## GRAFTONS

Seasoned  
Professionals  
understanding your  
Professional needs!

THE RIGHT ANGLE

SALES

## GRAFTONS



Phone  
698 7777  
Fax  
698 9999

THE RIGHT NUMBER

HIRE

# CONTRACTING

## NEW MEDIA ROLLOUT ROLLABOUT

Telecom contract Sydney firm for conference system

Telstra Corporation (Telecom) has appointed New Media Systems (NSW) to design and manufacture their new range of video conference rollabout systems.

The new product, 'Viewpoint' is offered in two basic formats, single screen and dual screen, and has the capability to operate at any transmission rate from 56/64K to 2 Meg. Both basic and primary rate ISDN switched calls are supported as well as Megalink private networks.

Based around the CLI Rembrandt codec, an AMX control system with tilting touchpanel provides ultimate flexibility, high performance and simplicity of operation. High resolution Sony CCD cameras, Fujinon lenses and Crown PCC microphones enable high quality vision and sound to be achieved. Options include

multi-media interactive devices, document visualisers, computer scan converters and a host of specialist interfaces.

Designed as a top-of-the-market product, the Viewpoint is presented in a smart mobile cabinet and utilises a Sony 34" colour monitor.

\*Info: Mike Dodds, New Media Systems, (02) 418-6388.

## Lighting Dealer Design Service introduced by CDA

Following the concept that selling means more than cartons and phone calls, Coemar deSisii Australia will now assist in layout, design and proposal presentation for any nightclub, stage lighting TV or film project. The firms dealers get this for free, including electrical & installation drawings.

## CHASING MALAYSIA

TRADE TRIP PAYS OFF

Malaysia is in the middle of a building boom, with three projects alone valued at over A\$5 bn underway. Prompted by this boom, a private trip was made by seven Australian suppliers recently.

The visit was hosted by Burwood Publishing who are a Melbourne based building projects information publisher. They produce a guide to projects planned and underway in Australia and Southeast Asia.

Brian Warn from Burwood Publishing says further such trips are planned to Southeast Asian countries in 1994, various Australian architects and consultants have established offices in Asia.

Call Brian Warn for more info (03) 819-9463, fax (03) 819-4179.

## Buyers Guide Test Gear (continued)

20Hz-20kHz band with a high sensibility of 0.1% full scale. An auto-tuning circuit enables distortion to be measured easily in the 1% and lower range.

**Boonton Electronics Scientific Devices Aust.** (03) 579 3622

**8201 Modulation Analyser** \$17,000.00 ex tax. The 8201 provides precision modulation and audio analysis in a single easy to operate package. Measures AM, FM, PM carrier and audio frequencies, SINAD, distortion and carrier level.

**8211 Modulation Meter** \$4,703.00 ex tax. This low cost, highly accurate instrument automatically measures AM and FM of carriers from 2 to 1500 MHz.

**1130 Distortion Analyser** \$7,000.00 ex tax. THD + Noise, RMS and Avg. level, SINAD and Frequency are all measured quickly and accurately with this reliable instrument. Three low-pass filters are standard and nine

# MEASURE WITH PLEASURE

# New!

## The A2 Audio Measurement System

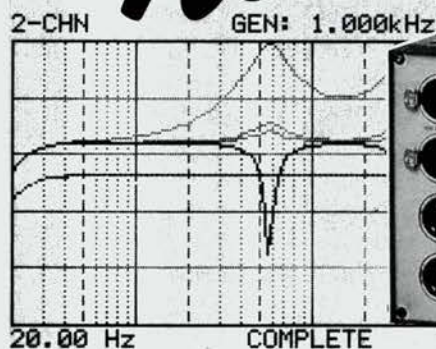

- Full Dual Channel
- Communicates with PC
- Multifunctional DSP generator
- One key - one function
- Storable, large graphics display and printouts



For information on the full Neutrik Test Equipment range, please contact:

Sydney:	Ph. (02) 975-1211	Fax (02) 975-1368
Melbourne:	Ph. (03) 646-5811	Fax (03) 646-5887
Brisbane:	Ph. (075) 29-0619	Fax (075) 73-1650

**NEUTRIK**  
CONNECTING THE WORLD

Write in Reader Service number: 133

# AUSTRALIAN FRIENDS OF MACKIE



Billy Fields, singer/songwriter, owner of Paradise Studios, Sydney, and proud owner of a CR-1604 & MS1202

“Crisp, clean transients with plenty of headroom, which gives you a big sound”



Jo Breen, owner of Soundlevel Studios, Sydney, and new owner of a 24-Bus Console

“Very quiet and clean, easy to operate. Engineers can't believe it's a 24 channel, so compact and the EQ surprises a lot of people”

“You can hear so much more in the mix”  
Tony Hystek  
Action Sound, Sydney  
32-B console

“Sounds great and fits into my gig bag”  
Mark Collins, mega banjo picker, MS1202

# 100 MORE REASONS TO BUY A MACKIE CR-1604 OR MS1202 MIXER

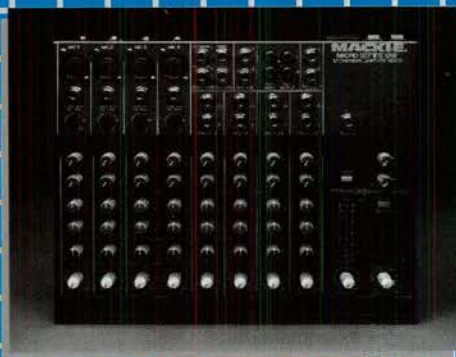

**MS1202...reduced to \$1049**



**CR-1604...reduced to \$2995**

Mackie compact mixers are the choice of professional musicians, producers, film and video editors, etc., etc., from all round the world and of course, here in Australia. What's more, these mixers have just become even better value for money. We've dropped the price by \$100 on both the CR-1604 and the MS-1202 to meet the competition head-on. In less than three years, these Mackie mixers have become the industry standard for compact mixers.

Used on world tours by Genesis, Madonna, Whitney Houston, Paula Abdul, INXS... Composers who contribute soundtracks to TV shows such as The Simpsons, Beverly Hills 90210, Hanna Barbera Studios, Lucas Films, Warner Brothers Studios. The list of Mackie users grows daily. Call your local dealer and see for yourself what is setting the standard in today's demanding digital world.

Need more information?  
Call or fax us today for a FREE 24 page 'In Your Face' journal and/or 'Application Guide'

## MACKIE 8-BUS MIXERS IN DEMAND!

The new Mackie 8-Bus Mixers have taken the world market by storm, just voted 'Most Innovative Mixer' at the NAMM 1994 Show. Unfortunately Mackie can't meet the demand at the moment and will not sacrifice quality to speed up the process. They are constantly improving production and building more mixers every month. If you have a Mackie 8-Bus mixer on order, or you are thinking of doing so, we apologize for the delay in delivery, but when you get one it will definitely be well worth the wait. (Delivery approx. 12 weeks from order)

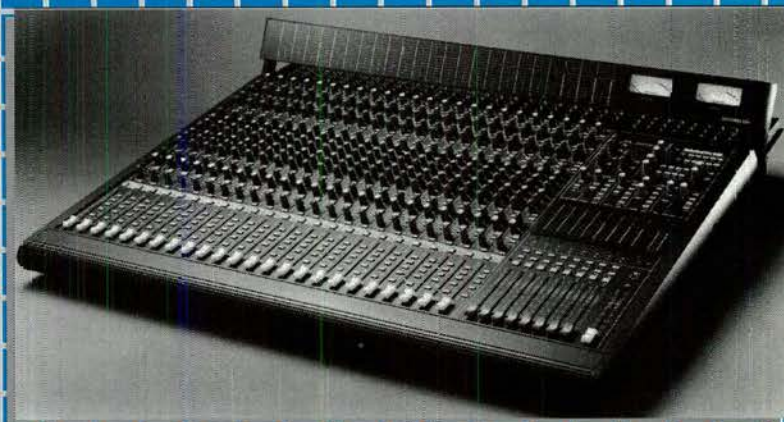

# MACKIE

Distributed by AUSTRALIAN AUDIO SUPPLIES • 256 VICTORIA ROAD • GLADESVILLE N.S.W. 2111 • PHONE (02) 879 6124 • FAX (02) 817 1049 • MOBILE 018 432 910

# CONTRACTING

## RANE CM86 COMPACT MIXER

The CM86 fulfils all requirements for fixed installation and transportable mixers in a 133mm (3 R.U.) x 483mm x 135mm package, say Jands. Its features include separate microphone and line connectors with a selector switch that doubles as an input mute, phantom power for each input channel and overload indicators on both the front and rear of the unit.

A two band shelving equaliser with in/out switch allows quick A/B comparisons between equalised and unequalised signals. Each input signal is assignable to Master Output A, B or both, with separate level controls for each. Individual assign switches for the two Aux outputs provide a choice between taking this signal before or after the "Channel Level Control".

All assign switches being small and unobtrusive, allow tailoring of all six mix outputs. The front

panel mounted switches allow custom setting of each output mix.

As well as the normal output overload indicators, the CM86 includes unique "pre-Output overload" LEDs for accurate monitoring in multiple summing stages.

To expand the CM86, plug two CM86s together to create a 16/6 mixer in six R.U... Single units can be augmented with any number of "Flex" modules that use the Flex bus system, providing versatility for any signal control requirements. Call Jands, (02) 516 3622.

### Contractors Sign

Glantre Engineering, The PA People, Peavey, Jands, Horwood, Audio Telex and AWA are some contracting and supply co's in this sector to commit to space at the forthcoming ENTECH '94 trade-show, for October 6-8 in Sydney.

## Shure AT mic

The Shure STM-34 mic can be installed on the ceiling-up to a 3.05 metre height-or walls of conference rooms, for un-obtrusive pickup. The maximum sensitivity of the mic is perpendicular to the mounting surface, creating a highly direction pickup pattern. It can be used with Shure's Teleconferencing systems, or in other system designs.

Details from Jands (02) 516-3622.



NEXT CONTRACTING NEWS  
DEADLINE 15th APRIL

## Buyers Guide Test Gear (continued)

popular option filters are available.

**1110 Audio Oscillator** \$7000.00 ex tax. This programmable sine wave generator features very high spectral purity and level accuracy. Frequency and level sweeps, 1mHz resolution and 31dBm output are standard capabilities.

**DOD** from Central Musical Instruments (03) 315 2244

**Real Time Analyser (DR-RTA)** \$929.00. 31 Band real time analyser with five LEDs per band in a single rack space. Includes pink noise generator and calibrated microphone. For analysis of room acoustics and sound systems.

**Neutrik Amber Technology** (02) 975 1211 John Fitzpatrick  
A1 \$6800.00. Compact audio test system providing generator with sweep, noise meter, level/freq/x-talk meter, distortion analyser, oscilloscope, W & F meter and curve tracer. Options include phase meter.

(continues)

# PURE LOGIC

The Soundtracs SOLO MIDI set new standards in combining uncompromised performance and versatility with affordable pricing. Now the SOLO LOGIC adds 12 bit VCA fader automation, full metering on all channels, plus on-board machine control.

The Logic's integral fader and mute automation uses a high speed internal processor and unlike some lesser systems, requires no external PC, provides full 12 bit fader resolution (4096 steps) and is quick and simple to use.

**THE SOLO LOGIC - PURE PERFORMANCE HAS NEVER BEEN MORE ACCESSIBLE!**

# SOUNDTRACS SOLO

Available from: **TURRAMURRA AUDIO SALES**

1267 Pacific Highway  
Turramurra NSW 2074  
Phone: (02) 449 8487  
Fax: (02) 449 3293

**SOUNDCORP PTY. LTD.**

30 Gold Street  
Collingwood VIC 3066  
Phone: (03) 416 1066  
Fax: (03) 419 6963

Distributed by: Amber Technology Pty Ltd. Phone: (02) 975 1211 Fax: (02) 975 1368

Write in Reader Service number: 154

# International Crossing

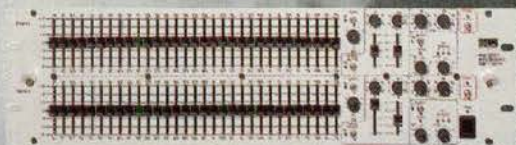

### Graphic Equalisers

Extensive range of graphic equalisers featuring active balanced inputs & transformer balanced outputs. Featured EQ23 ISP-R with full dynamics processing.



### Conference Mixers

MX32 features 3 mic inputs, priority voice over, mono/stereo program inputs and EQ. EX62 6 mic input expander/mixer.

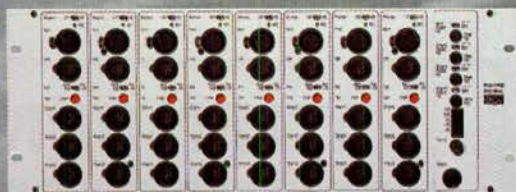

### Microphone Splitters

824 MkII - 8 channel active microphone splitter with options including Test Module, Power Fail Relays & Passive Splitter Transformers.



### Signal Processors

MEQ5 - Triple stereo program equaliser.  
PFL52 - 5 band parametric equaliser.  
BCL2 - stereo compressor/limiter with de-esser.

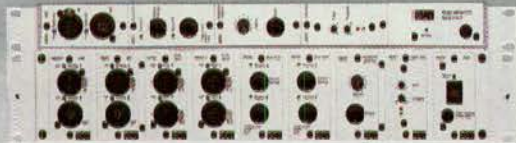

### Universal Buffer System

Modular problem solving system for level matching, impedance conversion, balancing, etc., etc. 2, 4 & 8 channel frames available.

SCV Electronics produce one of the most extensive ranges of signal processing solutions for PA, Contracting and Broadcast applications.

Everything from Equalisers to Microphone Splitters. Conference Mixers to Di Boxes. Compressors to Phase Checkers and the unique Universal Buffer system.

SCV equipment is used and specified by a veritable "who's who" of audio professionals worldwide.



Find out more about SCV  
call A.R. Audio Engineering  
0(2) 299 3666.



## Far East (North) Asian Report

By Ray Bond

### ESA have NACON

Most people who have attended large conferences know the sound they hear can sometimes be from behind them, and bear no relationship to the position of the person speaking. It adds to fatigue.

The NACON amplification system can localise the position of a person talking, so optical and acoustic perception are matched, for greater listening ease.

It makes for better system design, and works via a position coding network and a routing matrix, controlled from a PC.

The system will time align speaker zones and work with seemingly huge numbers of microphones and even people speaking in strange tongues! (Joke)

Call the ever helpful people at ESA for more. (03) 562-4605.

• Most Australian companies involved in the disco or nightclub business in the mid 80's would know of the Singapore Trading Company HAWKO. They could supply virtually anything you needed in the lighting field. Well the big news here is that this famous firm has had a not so amicable split with the former M.D. and 25% share-holder Mr. Yeo, who has set up an opposition company less than 1km away and taken 7 of the staff with him. Legal action is threatened! Stay tuned.

• I am always being asked about the costs in doing business in Singapore and thought the following numbers may be useful:- Warehouse rental (bare space!!) \$3AUD per sq.ft and this figure is per month not per year! Electricity charges, about 2 times Australia's per unit plus you use more as Aircon is a must all year round

everywhere. Motor vehicles, well that's another long story...

• I just paid out over \$60K AUD's for a company vehicle here. Did I get some exotic BMX, perhaps a baby Lexus? No, I got a ute and the only good news is that it has gone up a further 10K since I got it in October. You see, to stop Singapore becoming another Taipei, Jakarta, K.L. or worse still Bangkok, we have a vehicle quota system that means before you go and lay your money down for a car, you must bid for a "Certificate of Entitlement" which lasts only 10 years and currently costs over \$60 for a 2 litre car. This adds up to \$120K for a Toyota Corolla and \$150K+ for Holden Calais. Singapore is expensive.

• Singapore is very much the Nightclub capitol of Asia, if not the world. The latest to open is Singapore's first Studebaker's, which is disappointing. Also recent openings by the giant Spark's in Nee Ang City (over 35,000 sq.ft) and the Taiwanese owned Thunderstorm which took over the whole of a 3 storey department store (7,000 sq. ft). Not counting the Karaoke lounges (well over 300 island wide on last count) there are now more than 40 pubs and clubs in Orchard Road alone!

• I am now well into my second year here in Singapore and business continues to grow for us, particularly in the dimming business. We are very fortunate to represent renowned Aussie lighting maker, Dyalite, through most of the region and after a year of learning the ropes, we now have started to see some promising results. We have just secured two large dimming projects; one with over 280 dimmed circuits in Brunei (a sports hospital non the less) and the other for the Singapore Tourist Promotion Board's brand new building.

It will be one of Singapore's first Intelligent Energy Conscious building with almost 1000 dimmed channels all computer controlled and linked to minimise energy usage.

\*RAY BOND is part of TeDeum, a contracting/supply firm based in Singapore. An Aussie abroad.

### Buyers Guide Test Gear (continued)

**Nuetrik (cont) A2** \$10,580.00  
Dual channel version of A1 with multi-function DSP generator, P.C. compatability, printer port and a wide range of system options.

**Tektronix (02) 888 7066**  
Various equipment, contact them

**Kenwood** from Nilsen Instruments (02) 736 2888

**HM-250 Automatic Tuning Distortion Meter** \$2056.00 ex tax  
Automatic fine tuning over frequency range of 20Hz to 20kHz high sensitivity 0.1% full scale distortion meter and 100uV AC volt meter (10Hz to 200kHz), single operation calibration, XY outputs.

**AG-252 Audio Generator** with Sync. Oscillator Function. \$832.00 ex tax. Wide frequency range 10Hz to 1MHz, flat output voltage 30Hz to 50kHz  $\pm 0.2$ dB and  $\pm 0.5$ dB over entire range, low distortion over audio band 0.008%, can be synced to external signal, sine any square output, 0 to -50dB attn.

**AG-204 Audio Generator** \$486.00 ex tax. Wide frequency range 10Hz to 1MHz, flat output voltage over audio - frequency range  $\pm 0.5$ dB over entire range, can be synced to external signal, sine and square wave output, 0 to -50dB step attenuator. Low 0.02% distortion.

**AG-203A Audio Generator** \$392.00 ex tax. Specifications as per AG-204 except distortion 0.1%.

**FL-180A Wow/Flutter Meter** \$1835.00 ex tax. Measures Wow & Flutter over range of 0.003% to 10%, 0.5MV input sensitivity, RMS/Peak/Average meter indication, 3/3.15 kHz measuring frequency (J15, NAB, CCIR & DIN), built in filter for weighted measurements.

**FL-140 Wow/Flutter Meter & Drift.** \$1164.00 ex tax. Measures Wow & Flutter over range of 0.03% to 3%, RMS and peak meter indication, 3/3.15 kHz measuring frequency (CCIR, DIN & J15), built in filter for weighted and unweighted measurements, also drift in rotational speed can be measured.

\*\*\*\*

**Editors Note:** The listings in this section only scratch the surface. Many great and wonderful things exist in the 'Test Gear' realm, like MLSSA and SCV's great phase checking device. Because this is only our first annual Test Gear Buyers Guide many distributors didn't get it together to respond.

## ATTENTION CONTRACTORS:



### AN OUTSTANDING OPPORTUNITY...

Call John Ireland for details of a huge, cost effective range from the U.S. with our 3 year warranty.

Australis Music Group  
P.O. Box 518  
Brookvale, NSW 2100  
Phone: (02) 938-3466  
Fax: (02) 905-3142

Australis Music (NZ) Ltd.  
P.O. Box 21-232  
Henderson, Auckland 8  
Phone: (9) 837-3230  
Fax: (9) 837- 3232

Write in Reader Service number: 148



## 3 TAP TIME DELAY FROM PEAVEY

Peavey's Architectural Acoustics range is shaking up the American contracting market, with a staggering range of products encompassing virtually everything audio.

Typical is the IDL 1000 Multi-Tap Delay Line, a one rack unit tall processor with extensive features that retails for \$989 inc.tax.

This is a two input, 3 output multitap digital delay designed primarily for time alignment in multi speaker sound systems. It is capable of up to 1.35 seconds of delay, which would align a speaker system approximately 500m in front of another, if my math is right.

The minimum delay is 20.8 milliseconds, which is the increment that you can increase each time

to the maximum delay, 1,350ms.

You can set a delay in feet, metres or time, each output can be muted or temporarily reset to zero delay, and when done a rear panel security lock prevents meddling.

In mono mode the IDL 1000 has three separate outputs, or

'taps'. In Stereo mode you have a stereo pair output plus a single, separate mono in/out tap.

It is possible to establish separate stereo and mono delay memories, and the input and output levels can be screwdriver set then covered with a security panel.

Peavey's manual also briefly details the theory of time delay, and gives the math you need to work it all out - although being able to set delay times in feet or metres you won't need this.

*\*Call John Ireland at Australis for more info, (02) 938-3466.*

### Multimedia/AV World

*Every second month, starts next month. Video, visual and display technology. Deadline: 15th March. Hurry!*

Editorial Material: Fax (02) 876-5715, or PO Box 439, Epping NSW 2121. Send Photos!  
Advertising: Call Caroline Grafton, (02) 876-3530.

### CONTRACTING

*Every second month, alternating with Multimedia World. Next Deadline April 15th. (Don't wait!)*

**SONTEC**

VICTORIA

&

**BOSE**

AUSTRALIA

are pleased to invite you to see, hear and feel

## HOW IT ALL WORKS

- Bose Panaray Sound System
- I.Q. Controllers Sound System
- Crown Microphones
- Crown Amplifiers and more
- Crown Multiplexes

### If You Work In The Following Areas:

- ▲ Entertainment Industry
- ▲ Education/Music Departments
- ▲ Radio/TV Stations
- ▲ Sound Recording Studios
- ▲ Churches
- ▲ Universities
- ▲ Audio Equipment Specifiers

**PHONE (03) 570 3777 NOW TO RESERVE YOUR FREE SEAT  
And Enter the Draw to Win a Crown Microphone.**

**Tuesday 26th April '94 - 10.30am & 2.30pm  
Wednesday 27th April '94 - 11.00am & 3.00pm & 6.00pm**



### OUR PROJECT:

## OLYMPICS AQUATIC CENTRE

You may or may not be aware that TCP is the successful bidder for the Olympics Aquatic Centre. My contribution is based around this.

Total Concepts was awarded with the contract to supply the audio system for this project in February of 1993.

Since Sydney's successful bid for the games in the year 2000, this project has taken high precedence in the media. I thought your readers might enjoy to read some of the facts behind the design and implementation of the audio systems.

The centre is projected for completion in October of 1994. Or at least it was until we won the games. Since then the centre will grow from a seating capacity of 4000 people to a venue that will seat over 12000 people. A major re-think of not only the audio system but indeed the entire centre is in order.

This will be done by removing one of the walls and the grand stands being extended. Major stuff considering the building is over 200 meters long.

The system itself was designed by Barry Webb and Associates who have spent years on the design of this project, not only the audio but the electrical as well. The engineers have designed a system that can be divided into three distinct areas or combined as one large system. Acoustics in this venue, as you can appreciate, would be quite critical and this has been left in the hands of Louie Challis.

Construction of the project is by Civil and Civic and I wouldn't wish that task on anyone. This is not your simple put up four walls and slap on a roof type of project. The roof structure of the building is being constructed progressively at

one end and physically launched to the other end. The swimming pool floor is adjustable in depth across the full fifty meters of the pool. I worked with these guys at the ANA Hotel last year so I know how they're used to performing miracles. They also know how to throw a great party, as the night of the bid announcement proved!

The audio system itself is based around the Bose Panarray loudspeaker system. There are forty-four of these in total. For those of you not familiar with Panarray, it looks like a Bose 402 that's been left out in the sun and bent in the shape of a banana. It sounds pretty good though. Bose amazes me though. How many other uses and applications can you find for a 4.5 inch loudspeaker? Special thanks to Dave Adams from Bose for his assistance on this project.

Amplifier power is provided by the new Jands SR-3000, an amp that we've used in hire since its release and think it will be more than capable of handling not only the Bose speakers and hearing aid induction loop, but the approximate 6km of cabling from amplifiers to speakers. Hey, not everything is perfect! It would have been nice to have cut the cabling down somewhat. Thanks to Peter Grisard and Gary Rutter from Jands who gave us a hand with the induction loop and calculating amplifier loading etc.

I am pretty sure I have gone over my 600 words, but I must say this. The Olympics, we deserved it, and from whatever political persuasion you are, you've got to thank the team that went over to Monte Carlo and brought home the best prize of all.

-Anthony Musico, Director, TCP

### 100 Volt Commercial Range

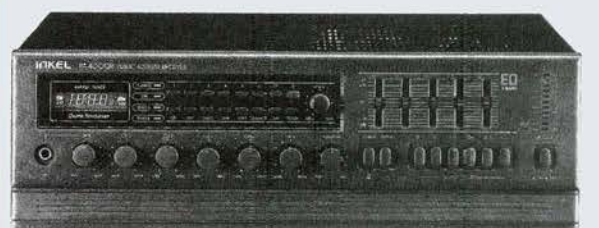
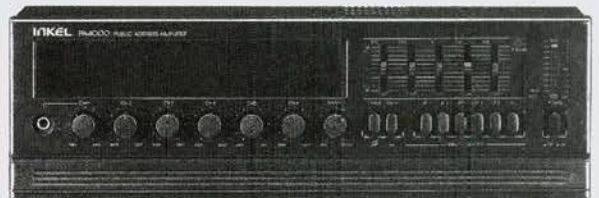
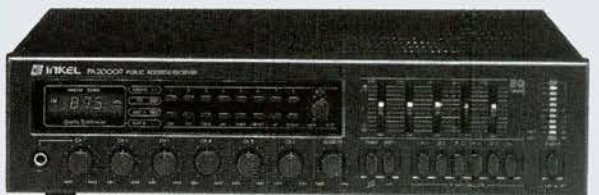
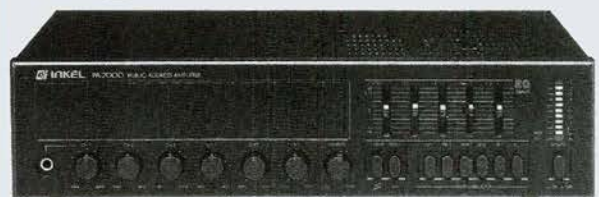

INKELS' range of 100 volt line mixer receivers and amplifiers, available in 30W, 60W & 120W (RMS). This range out performs the competition for features, reliability, quality and is competitively priced. Features include: All balanced inputs, switchable line/mic input XLR, 5 SPK zones chime & graphic.

For more information on the INKEL PA range of commercial products, contact your nearest INKEL PA dealer or phone:

<p><b>Australia:</b> Magna Systems &amp; Engineering A trading division of Silklore P/L, ACN 004 004 997 7 Gibbes Street, Chatswood, NSW 2067. Phone: (02) 417 1111 Fax: (02) 417 2394</p>	<p><b>New Zealand:</b> Magna Technics (NZ) Ltd. Level 4, 210 Khyber Pass, Newmarket, Auckland. Phone: (09) 307 3901 Fax: (09) 307 3832</p>
--	--

## New Contractor Series

Purpose built quality range of low cost amplifiers designed specifically for commercial audio installations. The C600, C800 and C1200 offer superior audio performance with high power in a compact 2U chassis, full circuit protection, 100 volt line option and legendary reliability endorsed with a full five year warranty.



## LANDMARK Studio Monitors

Designed for ultra critical near and midfield monitoring applications. LANDMARK is the result of thousands of man hours of research, development and intensive studio trials. LANDMARK demonstrates true clarity, definition and solid imaging.

Call A.R. Audio Engineering for a demonstration. Telephone: (02) 299-3666



Distributed in Australia through Australian Monitor Pty Ltd.

53 College Street, Gladesville N.S.W. 2111. Telephone: 61 02 816-3544 Facsimile: 61 02 817-4303

Distributed in New Zealand through Impact Audio. Telephone: 64 03 688-1191 Facsimile: 64 03 688-1193

Write in Reader Service number: 107

# Acoustics — and how YOU are affected

## with Glenn Leembruggen

This month we are continuing our break from the discussion of why the sound system must be designed to suit the acoustic environment to have quick look at some aspects of environmental noise legislation as it affects the music industry.

As most of you will know, the Liquor Administration Board (LAB) in NSW applies certain conditions to the entertainment license for live or recorded music to a pub, club, or nightclub. These conditions include criteria for the levels of noise from the venue reaching residents and are usually similar for most venues. The noise level criteria are derived directly from guidelines issued by the Environmental Protection Authority (EPA). Basically, if the noise level from the music reaching the nearby residents is within the criteria, then all is well, if it is outside it, then a lot of a hassle could be on the way for the venue.

Recently, the NSW LAB changed the criteria in the favour of residents, and in the long term this is going to have a big impact on venues and live/recorded music. To meet the new criteria, the level of noise emission from venues will have to be a lot lower and this is going to create hassles.

Before moving onto what the exact old and new criteria are, let me explain a few relevant terms.

**L<sub>10</sub>** Music has continually short and long term variations in level over time. If sound levels from music are measured on a sound level meter which is set to "Fast", then both long and short term changes show up. If the meter is set to slow, only the medium and long term variations show. Short term changes result from such things as snare drum hits (*no drummer jokes please*), vocal blasts or a loud guitar notes. The L<sub>10</sub> level is that level which is exceeded in only 10% of the total time during which the sound level is measured with the meter set to "Fast". As an example, imagine that you were measuring the level of music noise outside a gig using a sound level meter for say 10 minutes. In this 10 minute period, the meter might show sound levels ranging between 55 and 67 dB. Now, imagine a level, say 64 dB, that the music noise is less than for 90 % of the overall time you looked at the meter. In other

words, for 10% of the time (a total of 1 minute made up of much smaller time sections) the level exceeds 64 dB. The L<sub>10</sub> level is then 64 dB. Generally, the L<sub>10</sub> level reflects the average maximum level of the music noise.

**L<sub>90</sub>** Background noise also has continual short and long term level variations. The L<sub>90</sub> level is used to measure background noise and is the level that is exceeded in 90% of the total time in which the background noise level is measured. Again, imagine that you were measuring the level of background noise outside a gig using a sound level meter for say 10 minutes. (The band is not playing during this time). In this 10 minute period, the meter might show levels ranging between 35 and 50 dB. Now, say that the background noise is greater than 38 dB for 90 % of the overall time you stared at the meter. In other words, for 90% of the time (a total of 9 minutes made up of much smaller time sections) the level exceeds 38 dB, ie the L<sub>90</sub> level is 38 dB. Generally, the L<sub>90</sub> level is the average minimum level of the background noise.

While ever cars, trucks and planes pass sporadically, the will be periods of almost silence, and the noise you hear will be the distant hum of traffic, surf or night animals such as frogs or crickets. The L<sub>90</sub> reading measures these quiet periods. The upshot is non continuous local traffic does not influence the background noise reading.

**A weighting.** A weighting is a correction factor built into sound level meter as a filter. It is a way of getting a sound level meter reading to reflect what is heard by the listener when low sound levels are present. The major effect of A weighting is to reduce the impact of low frequencies on the meter reading because at low sound levels, the human ear doesn't hear low frequency sounds very well. As the frequency increases, less reduction is applied. For example if a noise sound is at 125 Hz, the A weighting network reduces its measured level by 16 dB compared to the same sound level at 1000 Hz. At 500 Hz it reduces the level by 3 dB compared to 1 kHz, while at 2 kHz, it boosts the level registered by 0.5 dB com-

pared to 1 kHz. When a sound level reading is taken with the A weighting filter used, the reading is said to be A weighted.

**Octave bands.** The frequencies present in noise and music can also be divided into different groups or bands, for example one octave wide, a third octave and so on. For the LAB criteria, octave bands are centred at 31.5 Hz, 63 Hz, 125 Hz, 250 Hz and so on up to 8 kHz. The sound level of each band of frequencies is measured and the sum of all bands equals the original overall level.

**The old criteria.** The old criteria stated that before midnight, the overall L<sub>10</sub> level of music noise measured with the A weighting applied should be less than 5 dB above the overall L<sub>90</sub> level of the background noise, also measured with the A weighting. After midnight, the music could not be greater than the background.

The old criteria was effectively a comparison of the broadband (full spectrum) levels of music and background.

Imagine a scenario in which a pub which is close to a major road or intersection. There would be a significant amount of lower mid range and bass sound present from traffic movements and the measured background noise would reflect this low mid range noise. Say the pub building is normal and leaks at mid range frequencies and there the L<sub>10</sub> of the band is caused mainly by loud vocals, centred at 500 Hz. The person investigating the environmental noise impact of this pub compares the L<sub>90</sub> level (say 45 dB) of the low mid/bass range traffic sound with the vocal sound of the band. Say the L<sub>10</sub> level of the band is 49 dB. As the L<sub>10</sub> is less than 5 dB above the L<sub>90</sub> level, the music noise would be within the criterion and hence legal, and yet because of the way the human ear operates, the vocals would be quite audible above the low frequency traffic noise. In some ways, apples were compared with oranges, but as long as the numbers were OK, things were sweet.

**New criterion.** The new criterion compares apples with apples. Before midnight, the level of the L<sub>10</sub> sound energy from the band in each octave band should be less

than 5 dB above the L<sub>90</sub> level of the background noise in the corresponding octave band. After midnight, the difference must be 0 dB.

Back to the scenario. Say the L<sub>10</sub> of the band in this octave (due to kick and bass) was 40 dB and the L<sub>90</sub> level of the background noise (traffic) in the 63 Hz band was 38 dB. So far, -legal. The L<sub>10</sub> of the band in the 500 Hz octave would be 48 dB (49dB from above less 1 dB for other instruments) and say the L<sub>90</sub> of the traffic in the 500 Hz band was 35 dB. The music is then 13 dB above the background in this octave band, and hence 8 dB outside the pre-midnight criterion.

Masking of one noise by another occurs when the frequencies are close and the intention of the new criterion appears to be allow the background noise to more effectively mask the music noise.

With the new criterion, the publican now has a problem. A reduction of 8 dB is not easy to find. Bands hate turning down, and a new roof, sound locks and double glazing are expensive. Some times the bands are already playing at minimum volumes, and so the publican has no choice but to close the gig.

**The future.** It is my experience that residents are tolerant of noise levels which are significantly outside the criterion eg 6 dB. Then something happens to the residents; there is a super loud band, a group of loud drunks piss on their roses, or a new person moves into the neighbourhood. This event of new person breaks the camel's back and they begin to complain to the pub. Most publicans put their heads in then sand about noise complaints, hoping that they will go away. Eventually the publican becomes the worst person in then world, and the matter ends up in the licensing court.

Residents are becoming more aware of their rights under the noise pollution act and will continue to expect lower noise from pubs. This will result in the new criterion being applied to venues which have had live music for yonks, creating hassle for everyone, and work for the solicitors and acoustic consultants.

*Glenn runs Elecoustics, who consult in Audio. Call (02) 799-6742*

# Random Comment with Duncan Fry

## Dunk survives the great California Quake of '93

Where to begin? Let's start with Warren Zevon, who sang '*...and if California slides into the ocean, As the mystics and statistics say it will, I predict this hotel will be standing, Until I pay my bill!!! ...*'

I was sound asleep in my bed at the Penny Pincher motel on the early morning of 17th January when I was woken up by some strange noises in the room above me. It's funny the things that go through your mind when you wake up out of a deep sleep. My immediate thought was that some sexual deviate had picked up an elephant at a singles bar, brought it back to their room and was engaging in some practices of questionable legality. 'What are these people doing?' I thought; 'Don't they know it's 4.30 in the morning?' Long slow creaking and shuddering movements continued, getting louder and louder, when suddenly a light bulb went on in my head 'Uh oh, this is no elephantine hump...this is a fucking earthquake!'

What's the earthquake drill? Get under something solid like a door frame? No way. I wasn't budging from that bed. Wild horses would have had a hard time dragging me out of there. Instead, like the fearless, battle hardened, courageous road warrior that I am, I pulled the covers over my head and waited for it all to go away.

The movements got worse, and a really low rumble was clearly audible. The room seemed to float and bump. The feeling was like being in a dream with the bed bumping over a very bad road in a car with very soft suspension. It was a really eerie feeling. A primeval force of nature over which I had no control had me in its grip and wasn't about to let go until it had finished with me. Mother Nature flexing her muscles just to show us who's really in charge here.

Then, just as suddenly as it had started, it stopped.

Coming from a generation that believes that if it's not on TV, then it hasn't happened, I switched on the TV! Instantly I could see that I had got off lightly. On the screen there was a reporter who had been dragged out of the video department where he had been working, and shoved on camera. He looked scared shitless, and I can't say that I blamed him. The TV station was in the heart of the Valley, and had received the brunt of the shock. The newsroom behind him was a total mess. Ten or more 21" TV monitors had crashed off the wall on to people's desks, shelves had been pushed over and their contents had spread all over the floor, pieces of ceiling were hanging down. It's a cliché I know, but the place really did look as though a bomb had hit it.

TV pictures started arriving on the screen from the rest of Los Angeles, and it didn't look too good. An overpass on the Santa Monica freeway had collapsed onto the street below; another freeway junction had pancaked down on to the ground from about 50 feet up. Sadly a motorcycle policeman, looking to assess earthquake damage, had driven right over the edge of it and crashed to his death. Houses had collapsed, big office buildings leaned at crazy angles while others looked as though they had escaped untouched, except as you looked closer you could see that one side had collapsed - like a Dalí painting where objects drip off the sides of tables.

Fires burnt steadily from storm drains, as gas had seeped into the sewers from broken pipes and been ignited by passing cars. On the hills overlooking Studio City, numerous houses had just plunged down the side of the hill, leaving one car hanging by its rear wheels over the cliff edge. People who had scrambled for safety were stand-

ing in shock, staring as their homes disappeared before their eyes. Trailer parks were ablaze, their flimsy construction offering no resistance to the shock waves as they passed, collapsing and igniting escaping gas. In the Hollywood hills, chimneys had crashed through the roofs of houses, including that of friends who had invited me to stay with them!

In Northridge, an entire apartment complex had collapsed, killing at least 21 people. What were once 3 storey buildings were now 2 storey; the first floor was now where the ground floor had been. Only the fact that the ground floor had mainly been car parking had saved many more people from being killed.

The news images went on; a four mile long freight train carrying toxic chemicals had been derailed, a shopping complex had fallen down, and hospitals were turning people away because they were inundated with walking wounded and worse. To add to the chaos in the hospitals, they had only emergency lighting, no power and no water.

The bizarre events continued through the day. This was history in the making and I couldn't drag myself away.

The police recommended allowing another hour to hour and a half for your journey if you had to go along the Santa Monica freeway. This was definitely the understatement of the year. At a factory I visited a few days later, one of the people working there told me it took him five hours to get to work! The Santa Monica freeway is 8 lanes in each direction, and is the major traffic artery in and out of LA and Hollywood from the coast. In fact, it's the world's busiest freeway. Or was. If you couldn't drive on the freeway then you'd go along a major surface street in the same direction. Trouble was, the freeway

had collapsed right onto one of those surface streets, causing double the congestion.

And congestion it sure was. A TV news traffic helicopter (Telecopter!) showed us the Santa Monica freeway at night. A glowing trail of tail lights led up to the spot where it had collapsed, and then there was nothing - a black hole where everyone had to turn off the freeway - and a mile further on the traffic started up again.

Luckily for me, it was nowhere near as bad in Anaheim, where Walt Disney had decreed that there shall be no earthquake damage to scare off the tourists. Apart from the water being cut off for a while, meaning no shower and having to leave something resembling a sleeping anaconda in the toilet bowl for Conchita the maid to deal with, I escaped unscathed. The big 'A' and scoreboard on top of the Anaheim stadium, a construction weighing 7 tons, collapsed into the stands damaging about 800 seats, but that was about it.

The scary part was that I had been in Northridge the previous evening, looking at a car to buy. I'd driven right through the area that had been worst hit only about 6 hours earlier. In fact, I called the guy who had the car to see if perhaps it had been damaged in the 'quake, and whether he'd take less money for it now! However, although half his house had fallen down, luckily the garage remained untouched. Obviously the builder had got his priorities right!

Still, life goes on. And every cloud has a silver lining, even in the middle of an earthquake zone, where one person's disaster is another's business opportunity. As I drove through Anaheim the morning after the day of the 'quake, there they were on the corners:

"Earthquake T-shirts! A big one - 6.6 on the Richter scale! Come and get your earthquake souvenir TShirt!" •

# ROCK'ARD

**FINALLY! THE PAINT  
THE ENTERTAINMENT INDUSTRY NEEDS,  
IS HERE!**

- Water based
- Various textures achievable
- Touch dry in 30 minutes
- One coat only required

**ALL ENQUIRIES WELCOME**

Phone: (02) 550-3828  
Toll Free: 008 804-994  
Fax: (02) 550-6919

# SOCIAL PEOPLE



Stephen Found - Bytecraft boss, with his State Flying System - on which we will report sometime soon.



David Sloss - Studio Connections boss and former potatoe farmer. Ask him about spuds....

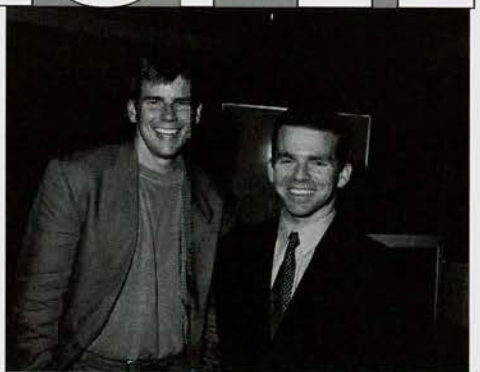

Left: Mark Ely - from Sonic Solutions (USA) with Right: Terry Marshal - Syncrotech System Designs



Neville Thiele - AES Vice President & Nice Gentleman. One half of the 'Thiele & Small' (Aussie) parameters team.

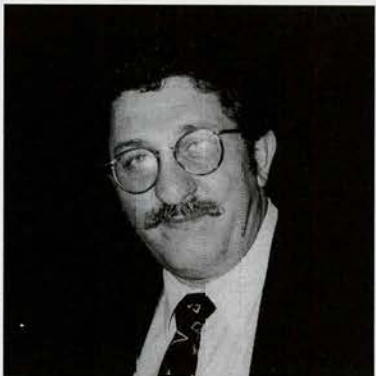

Mick Privitera - Australia Concert Productions boss, & political aspirant



Graham Thirkel - of Melbourne based Thirkell Holdings.



Left: Peter Norman 'walking audio theory encyclopaedia' and right: Garry Rhodin, from the Sony- Pro Audio Division.



Paul Payton, from BBE & Carlsberg importers, F. Payton & Sons



Alan Brown 'Brownie'- Centrestate Productions boss and part time hearse pilot. Stiff driver.



These two ladies are named "Q-Te" and are endorsed by Numark & Con Biviano of ULA is their OZ agent. Hmmm. Need a caption.....



David Hines-Australis Music Group-N.Z. Manager.



Our very own Catriona Forcer (left) on a really hard story quest at Sea World.

# Classifieds

THE ONLY NATIONAL CLASSIFIED ... CALL (02) 876-3530, or FAX (02) 876-5715 BY THE 25TH OF THE MONTH

## FOR SALE

AKG 451 \$350.00. "Rock & Roll Music 008 804 994, (02) 550 3828

Alesis MEQ230 dual 30 band equalizer, rackmount unit, as new, \$400 (08) 382 6234

Alum rack 16 space with front & back wheels & 2 removable shelves, VGC \$250 (03) 786 4137

Ampex MM1200 2in 16 track, EC, runs at 7.1/2, 15 & 30 IPS, SMPTE compatible, 2 reels of 2in tape, full workshop manuals, prof machines \$4800 (03) 386 8881 or (03) 387 9569

Amps Yamaha P2200 \$1000.00 each. Yamaha 2100 \$700.00 each. Jands 920 \$1200.00 each. H&H M900 \$1000.00 each. PTM 700 \$1000.00 each. Jands 516 \$2000.00 each.

Audio cables, suit 8 or 16 track studio, high quality RCA, Jack, phono 3 pin & midi cables, Belden cable, Neutrick & Gold connectors, 50 cables in all, as new cond. cost in excess of \$600 sell \$220 (03) 876 3121

Audio-Technica, conference condenser microphone, model AT857AM, unipoint pwr supply, cost \$500 sell \$250 (03) 531 7630

Berkey Colortran Mini-pro Lighting kit. Includes 3 mini-pro with barndoors, 3 stands and leads in aluminium carry case. Very good condition. \$790. CC'S LIGHT & SOUND Ring for free catalogue 008 803 064

Bose 101 \$150.00. "Rock & Roll Music 008 804 994, (02) 550 3828  
BSS c'overs FDS 360 \$1350. "Rock & Roll Music 008 804 994, (02)

550 3828

Cable Odds and Connectors from \$1.00 cleanout sale. Grafton's Sound Waterloo (02) 698 7777.

Cables, 12 mike leads, 5 speaker cables, Belden or better quality cable & Neutryk connectors, \$20 each. (03) 885 9485

Carpeted EV bass bins (2), \$650 or near offer. (085) 22 5250

Cassettes Players New and used from \$60.00. New Sherwood Dual cassette players \$2000.00 Grafton's Sound Waterloo (02) 698 7777

Cobra 2 x 15 subs. \$1000.00. "Rock & Roll Music 008 804 994, (02) 550 3828

Cobra MK1 Bins \$1500.00. EV1502 Bins. "Rock & Roll Music 008 804 994, (02) 550 3828

Complete Sound System 16 Channel Desk, EQ's, FX, Amps, Front of house speakers and wedges, \$10,000.00. Call Andy at Grafton's Sound Sales (02) 698 7777.

Deltalab DLJ \$250.00. "Rock & Roll Music 008 804 994, (02) 550 3828

Disco Mixer New and Ex-rental from \$200.00. Grafton's Sound Waterloo (02) 698 7777

Effects Klark Technic DN27 A Graphics \$1000.00 each. Fostex Stereo Compressor with Gate \$300.00. DBX 160X Comp. \$600.00. Yamaha D1500 \$700.00. (02) 550 3828. Jands Eightgate \$700.00. Richardson Eightgate \$700.00. Richardson Fourgate \$350.00. Effectron 1024 Delay \$250.00. BSS FDS 320 Stereo Cross \$1000.00. Simmons

Midimix \$800.00. Yamaha 1040 Crossover \$800.00 each. Sound Development 4 way Crossover \$300.00. White 4400 Eq's (Consecutive Serial Nos.) \$3000.00/pr. S'ndtracs m 32-8 dsk \$8000.00. S'tracs 32-2 \$8000.00. "Rock & Roll Music 008 804 994, (02) 550 3828

EV FM1502 Wedge \$600.00. "Rock & Roll Music 008 804 994, (02) 550 3828

EV RE 20 Mic \$700.00. "Rock & Roll Music 008 804 994, (02) 550 3828

Grafton's have a complete range of hardware and consumables for all you "Rock and Roll" needs. Grafton Sound, 6/890 Bourke St. Waterloo (02) 698 7777.

Graphic equalizer, Electro Voice \$200 EQ, \$299 or near offer (08) 332 1530



## Phil Allison

### Electronics Technician

- ★ Personal service from Sydney's most experienced tech in all makes of PA and Stage Amplification.
- ★ From Amcron to Zpe and everything in between (Even Jands!!) expertly repaired and restored to 1st class operation.
- ★ Tube Amps, desks and FX units also welcome. All types of mics, including Radio Mics a specialty.
- ★ Quick turnaround on most jobs (2 to 3 days).
- ★ Business located in Ashfield area.

**Phone (02) 799 8242**  
(6 DAYS)

# GRAFTONS

**SATURDAY  
12 MARCH**

## SALE

One Day Only - SAT 12th March  
9:30am - 4:30pm

### X RENTAL GARAGE SALE & SAUSAGE SIZZLE

Unit 6, 890 Bourke St,  
Waterloo

'94 HIRE CATALOGUE OUT  
NOW

Wholesale & Retail sales of  
Theatrical Supplies.  
Gel, Tapes, Hardware and More.

**PH. 698-7777**  
**FAX 698-9999**

Professional Lighting & Sound

## SMARTWALL VIDEOWALL

Ex Club Installation

3 x 3 configuration with 28" monitors  
plus controller and cables.

**\$25,000**

All offers considered.

**Black Express Light and Sound**  
Ph: (02) 559-4363



## P&E

### Professional Audio Electronics

**CRAIG MARSHALL**  
Electronics  
Technician/Engineer

SPECIALISING IN:

THE SERVICE & REPAIRS OF ALL TYPES OF PRO AUDIO EQUIPMENT, MIXING DESK'S, EQ'S, C-OVER'S, DIGITAL FX UNITS, SOLID STATE & VALVE AMP'S, TAPE, C.D. & DAT RECORDER'S DIGITAL AUDIO, & STUDIO ELECTRONICS.

DBX, SOUNDCRAFT, MIDAS, NEVE, SONY, BSS, AKG, KLARK-TECHNIK, YAMAHA, ALESIS, OTARI, AKAI, JANDS, CARVER, CROWLY, SHURE, PHASE-LINEAR, BEYER, MARSHALL & FENDER.

**PH: 645 1236 FX: 646 7028**  
421 GRAHAM ST, PORT MELB. 3207

### ADVANCED LIGHTING EQUIPMENT

Sydney Australia

*Specializing in metal equipment and engineering services for entertainment, exhibition and general industry.*

● design ● manufacture ● sales ● service ● hire ● installation

trussing systems-alloy & steel - lighting bars - telescopic push-up & winch-up stands - hooks & clamps - portable stage risers - customized mic. stands - custom brackets, frames & adaptors - set construction - video trolleys - TV brackets - drum kit repairs, modifications & rejuvenations - rigging accessories - transportation frames, dollies & cases - general engineering - architectural metalwork - site welding - lighting sales - installations - design and total project management.....

24 Shirlow St, Marrickville NSW 2204 Ph: (02) 557 4141 Fax: (02) 557 4135

**FOR SALE**

**JBL 12In speakers** (2) K120 \$300 each; (2) K120 reconed to 2202 \$300 each; 1 pr horns 2470 1in drivers with biradial flares \$800 pr (03) 802 5943

**JBL 2380A bi-radial flares**, 4 mths old, in new cond. with Gauss mdl HF4000 drivers, 2ins throat, new diaphragms, in sold cabinet, EC \$1200 the lot. 018 378 106 or (0059) 864 717

**JBL 4430 Studio Monitors**. Bi-radial horns & 15in speakers. Minimal use & in VGC, new cost \$12350 sell \$3950 (03) 853 5820

**JBL mini sub** x 2, 15in, 2226 driver plus Xover, carpeted \$1450 BH (052) 224 099

**Klark Teknik DN27A x 2** \$2000. \*Rock & Roll Music 008 804 994, (02) 550 3828

**Light Boxes** (3) 1Mtr. sq. black carpet console, 2 Realistic t/tables, pitch control, Arista mixer with tape deck \$800 (03) 460 2948

**Lighting desk**, Jands Event 48 plus, roadcased, 50 mtrs. data cable, 48 channel digital Demultiplexer, all immac. cond. \$12500. (054) 282219

**Loudspeakers** Australian Monitor BT350's \$2200.00 Inc. Stands. Grafton's Sound Waterloo (02)698 7777

**Loudspeakers** EV 15L and Piezo Horns \$1000.00 a pair. Call Andy at Grafton's Sound Sales (02) 698 7777.

**Microphone Boom stands**. New with clip \$60.00. Grafton's Sound (02)698 7777

**Mitec Roady** 16 channel mixer rack mountable ex-demo model \$2500.00. Grafton's Sound Waterloo (02)698 7777

**Mixer**, Allen & Heath, English console, 16-4-2, many features, incl. road case VGC \$1320 (03) 772 0121

**Mixing Desks** Yamaha 1532 \$7000.00. Yamaha 916 \$3000.00 LEM 32/4/2 6 Sends \$4600.00 (02) 550 3828. Soundcraft 800B 24/8/2 Immaculate \$14,000.00. Dynamix 24/8/2 Fully Serviced \$2000.00. Dynamix 16/8/2 New Faders fully serviced \$1600.00. Yamaha MC2404 Fully Serviced \$3500.00. Jands JM6 20 Channel \$700.00. Soundtracks 16/4/2 \$1400.00. Soundcraft 16 Channel Series 1 \$1000.00. Peavey 16/6 Foldback desk \$2000.00 in Roadcase. Dynamix 3000 24/8/2 Fully Serviced \$4000.00. \*Rock & Roll Music 008 804 994, (02) 550 3828

**Mobile Disco Equipment** includes turntable, CD players, speakers, amplifier, mixer & a few lights and chasers (079) 782 551 or (079) 721 761

**Myson** SM58 copies budget beaters. \$80.00. Grafton's Sound Waterloo (02)698 7777

**Neumann KM-83** Omni Directional Condenser Microphone. Excellent Condition. \$600. CC'S LIGHT & SOUND Ring for free catalogue 008 803 064

**New Bar Bases** \$650.00. New Packing Cases \$570.00. New 19" Equipment Sleeves from \$60.00. Grafton Lighting and Sound (02)698 7777

**Overeem** Bose copies 8 x 4" full range cabinets \$500.00 pair Grafton's Sound (02)698 7777

**PA bins** 2 off 15in woofers, 4 way system, each bin 250 watts \$800 evenings (03) 571 5117

**PA bins** 2 off 18in woofers 4 way system, grey carpet, each bin 400 watts RMS \$1090 evenings (03) 571 5117

**PA system** Yamaha EMX150 with 2 x 250w bins, plus Pro Amp power amp 950w, echo unit, all leads \$3000 AH (03) 369 1706

**Parraux** 6000c \$1400.00. \*Rock & Roll Music 008 804 994, (02) 550 3828

**Parraux** 6000c Biamp \$1600.00. \*Rock & Roll Music 008 804 994, (02) 550 3828

**Parraux** 6200 \$1400.00. \*Rock & Roll Music 008 804 994, (02) 550 3828

**Parraux** 8000c \$2000.00. \*Rock & Roll Music 008 804 994, (02) 550 3828

**Parraux** 9000 \$1800.00. \*Rock & Roll Music 008 804 994, (02) 550 3828

**Post Mardi Gras Sale!!!!** Last year we had a sale of ex-rental equipment on election day. This year, we are going to be different. We will have the sale, but not the election. Everything discounted. Grafton's Sound Sales (02) 698 7777

**PATRICK CAHILL & ASSOCIATES**

**THEATRE CRAFTS**

*Sound & Lighting for entertainment*

**Hire • Sales • Service**

**System Design & Installation**

Lighting-Dimmers-Effects-Drapes-Smoke Machines  
Colour Filters-Moving Lights-Strobes-TV Lighting

Strand • Prolite • Startec • LSC • Rosco • Kupo  
QuartzColour • Jands • Coemar-TAS • Bytecraft

Phone: (09) 227-7015

Fax: (09) 328-2787

Mobile: 018 917 235

468 Newcastle St., Perth, W.A. 6000.

**PLATYPUS PRODUCTIONS**



**Public Address Hire**  
**Lights • Trucks • Crew**  
Call Bruce or Mick  
**Ph/Fax : (07) 808 7744**  
**Mobile: 018 192 234**

**MATTHEWS AUDIO CO.**  
ELECTRICAL & ELECTRONIC  
Design • Installation • Service  
Licence No. 32064C

**BLACKTOWN & PENRITH**

- REPAIRS & DESIGN
- CONTRACTING
- INSTALLATIONS
- COMMUNITY RADIO
- SCHOOLS A SPECIALTY

*Paul Matthews* Phone: (02) 623 2860  
56 Magnolia Street  
St Marys NSW 2760 Fax: (02) 623 9999

**Hey** Good Looking, After a Good Time?

**Indulge your aural/visual fantasies with us!**

Our gorgeous staff are standing by, eager to please, including:

**Jim:** Mature, Silver-Haired, will take you to monitor heaven!

**John:** Let this cheeky operator light up your night!

**Jimmy:** This rambunctious rogue will leave you begging for more!

**Michael:** The boss and not afraid to show it! Dare you not submit to his demands?

**THE PUBLIC ADDRESS CO.**

**(02) 799 7219**

- Open till late
- Reasonable rates
- Discreet rear entrance load ins.
- All major credit cards refused

**"WE USE & RECOMMEND JBL SYSTEMS"**

**SYSTEM A:**

JBL DOUBLE 4 WAY STEREO.  
8,000 WATTS F.O.H.  
6,000 WATTS F.B. WITH 6-8 SENDS ACTIVE.  
40 CAN LIGHT SHOW. OPERATORS INCLUDED.

- ALSO TRIPLE & QUAD JBL CONCERT SYSTEMS AVAILABLE.

**Joe's P. A. Hire**  
Phone & fax (02) 564-2521

**SYSTEM B:**

RENKUS HEINZ DOUBLE 3 WAY.  
7,000 WATTS F.O.H.  
6,000 WATTS F.B. WITH 6 SENDS.  
30 CAN LIGHT SHOW.  
OPERATORS INCLUDED.

- ALSO SINGLE RENKUS HEINZ AVAILABLE.

**SYSTEM C:**

COMPOSITE SYSTEM

**Wild Gravity**

• SALES • HIRE • INSTALLATION

**10.000 WATT**

**DELTAMAX 1152**  
**IN NORTH QUEENSLAND**  
**WITH 32 CHANNELS**  
**F.O.H. AND 400B FB,**  
**AND OR 80 PAR CANS**  
**WITH 96 DIGITALLY**  
**CONTROLLED CHANNELS,**  
**CHAIN BLOCKS AND**  
**CLS TRUSSING**

PHONE NOEL ANTHONY  
**(077) 21 3540**  
OR FAX  
**(077) 21 1375**  
TOWNSVILLE

106 Boundary St. Townsville Qld. 4810

## FOR SALE

**PTM 1250MKII** Power Amplifier 625W x 625W @ 4 Ohms. Can be run into 2 Ohms. Very good condition. \$1290. CC'S LIGHT & SOUND Ring for a free catalogue 008 803 064

**Roadcases**, sleeves from \$60.00 and screws call Andy at Grafton's Sound Sales (02)698 7777.

**Sample Station Disco Mixer 4 Sec** and 8 Sec samples. Wicky Wicky only \$550.00 New. Grafton's Sound Waterloo (02) 698 7777

**Sennheiser 441** \$400.00. "Rock & Roll Music 008 804 994, (02) 550 3828

**Sennheiser ME80** Shotgun Condensers Microphones. Perfect for choirs and theatrical productions. Brand New \$450.00. Grafton's Sound (02) 698 7777

**Soundcraft 200B 16/4/2** 4 way Eq, 4 aux, 8 returns, excellent condition. Aluminium roadcase, great buy \$2999. Phone Simon (047) 59 2522 A.H. (047) 871 535

**Soundcraft spirit live 16 ch.** in case \$3000.00 Grafton's Sound Waterloo (02)698 7777.

**Soundworkshop 1600** 24 channel recording console in P.C. \$12000 **Neve** Latest model Prism with two Dynamic Modules (that's 2 mic pre's, 2 compressors, 2 noise gates) and 2 Eq. Modules P.C. \$8,800 **UREI** 537 1/3 octave graphic equaliser P.C. \$680 Phone: (07) 844 6844.

**Speaker Stands** suite EV \$100's or AM BT350's \$100.00 a pair - new-unbelievable value!!! Steel Fixed four leg base. Steel fixed upright no moving parts - Will not break - Grafton's Sound Waterloo (02)698 7777.

**Stage Box 30 way** \$150.00 Multicore cable 4 way \$8.00/MWAY \$12.00/M 16 WAY \$18.00/M 20 WAY \$22.00/M 30WAY \$35.00/M Grafton's Sound Waterloo (02)698 7777

**Superceded Models** Australian Monitor K7 \$2500.00 Grafton's Sound Waterloo (02)698 7777

**TASCAM T2640MS** High speed cassette duplicator master slave. Half price \$2000. (085) 630455

**Tascam 2 track m32** \$600.00. "Rock & Roll Music 008 804 994, (02) 550 3828

**Theatrelight 48 Control Desk.** \$2000.00. Grafton Lighting (02) 698 7777.

**Urei 1178** \$1600.00. "Rock & Roll Music 008 804 994, (02) 550 3828

**Wanted : 400W Intellabeams.** "Rock & Roll Music 008 804 994, (02) 550 3828

**Yamaha 2020 comp** \$450.00. "Rock & Roll Music 008 804 994, (02) 550 3828

**Yamaha 2031** \$700.00. "Rock & Roll Music 008 804 994, (02) 550 3828

**Yamaha EMX300** 12 Channel powered mixer 250W x 250W @ 4 Ohms. Excellent condition. \$2700. CC'S LIGHT & SOUND Ring for free catalogue 008 803 064

**Yamaha MR1242** 12 Channel mixer with 3 aux. sends and 3 way eq. with mid. sweep. Excellent condition. \$1800 CC'S LIGHT & SOUND Ring for free catalogue 008 803 064

**Yamaha SPX900** \$1000.00. "Rock & Roll Music 008 804 994, (02) 550 3828

## EMPLOYMENT

**Warehouse Manager Wanted**  
Leading production company based in the South Melbourne area, requires the services of a Warehouse Manager to keep track of a large inventory of stock and to perform a hands-on role in preparing production rigs, organising crew and generally ensuring the entire process runs smoothly. Good people and organisational skills are a must and previous experience in sound, staging and lighting production is preferred, but not essential, providing you have previous storeman experience in a service orientated environment. Salary commensurate with experience. Applications accepted in writing only. Resumes should be forwarded to The Business Manager, PO Box 5030, Garden City, Victoria, 3207.

**Electrical Engineering Assoc. Dipl.** student required part-time, casual to work in Audio/Lighting maint. repair role. Wide range exp.; know. in electr. esp. amplifi., lighting & micro processor equip. - Ben (02) 477 2126

## SALES PROFESSIONAL FOR LEADING SOUND REINFORCEMENT EQUIPMENT MANUFACTURER AND DISTRIBUTOR

A world leader in professional audio is seeking a highly motivated self starter with a proven track record in closing sales and creating lasting business relationships with clients.

Experience with professional loudspeakers, amplifiers and associated electronics with particular focus on the contracting market is necessary. In addition a knowledge of the rental and broadcasting markets and computer literacy would be advantageous.

Mark IV Audio offers a competitive salary and benefits package including a company vehicle and challenge of working for a world leader in the professional audio industry. If you can meet the above requirements and would like to join our team please forward your resume to:

**The Sales Manager**  
**Mark IV Audio (Aust.) Pty Ltd**  
P.O. Box 427, Rydalmere, N.S.W. 2116.

Quality Tri-Truss with engineering report.  
• Available locally at competitive prices  
• Completely C.L.S. compatible

# Tri-Truss

3 metre lengths

- Floor base plates
- Truss to tree adaptors
- Bolt sets
- T-piece adaptors
- Spigots
- Right angles, vertical & horizontal
- All available individually or in sets

**Current Special Rate of \$1250+tax for 3 x 3m length Tri-Truss, Spigots, Bolt sets & Truss-to-tree adaptors.**

**Collins & King Pty. Ltd.** A.C.N. 007 343 759

Factory 3, 44 Rusdale St., Knoxfield VIC 3180 For Sales Phone: (03) 764-9191

## STUDIO SOLUTIONS

THE PRO AUDIO & VIDEO SPECIALISTS



- Repairs
- Maintenance
- Sales
- Installations

Call  
**Howard Jones**

Suite 105, 511 Pacific Highway,  
CROWS NEST NSW.  
Phone (02) 906-4363 Fax (02) 439-6444



**damieng**  
**gerard**  
SOUND STUDIOS

## Professional Recording & Rehearsal

**RECORDING  
REHEARSAL  
STORAGE  
SALES**

(Inc. Miniflex™ Acoustic Mic's)

**HIRE**

(Inc. Apogee Digital Filters)

For information & bookings  
call (02) 660 8776  
Fax: (02) 692 9915  
64-80 Wattle Street  
Ultimo NSW 2007

**BIG TRUCKS**  
can cost you  
**BIG BUCKS** so....

Two years ago we introduced our small OB Van, to provide our clients with an efficient, quality environment for handling multicamera shooting and multimedia presentation, on limited budgets.

We've covered corporate functions, teleconferences, training workshops, rock concerts and cultural events. We also use the van to handle studio shoots, two-ways, multimedia presentations and feeds to big screens. Not to mention recording of entertainment & cooking programs for broadcast.

The van contains: Sony 2550 vision switcher; Soundcraft audio desk; Barco technical monitoring; 6 CCU's for our DXC CCD cameras; Talia talkback; 3 framestores; Ultimatte; Graphics computer; Up to 4 SP Beta VTR's; and a separate presentation mixer (for screen feeds).

A second van contains: Lighting and dimmers; Doorway dolly and jib; Autocue and extra audio gear. And we're fully supported by our multi-format on-line edit suite.

To keep our standards high, we use only broadcast-experienced freelance crews. And we like to plan our jobs carefully!

**Mobile Image Co.**  
Facilities for Television & Video Production  
Westleigh St, Neutral Bay, NSW, 2085  
Phone 02 953 3833.

# CENTRE STATE SOUND & LIGHTING

TOURING PRODUCTION,  
TRANSPORT, DRIVEWAY  
HIRE, RETAIL SALES

**PA:** 32ch Soundtracs,  
800W TO 18,000 WATTS  
Australian Monitor QMX,  
F600 & SLAM boxes, BT 350  
Delay System.  
**FB:** 8 Send Spirit mon. desk,  
wedges, side & drumfills.  
**LX:** Instinct 48, 16 - 80 cans,  
1000w profile spots, 2  
followspots & F/X. Trees,  
trussing, blacks and risers.

AVAILABLE DAILY,  
WEEKLY ANYWHERE



Call Allan Brown  
ORANGE NSW

063 620-587

## FERNANDEZ musicentre

# CAIRNS

NORTH QUEENSLAND

Concert P. A. Systems.  
Multi-Pin Lighting  
( up to 100 cans available)  
Professional Experienced  
Operators And Crew.  
Instrument Hire.  
Qualified  
Service Technician

Soundcraft Desks, Jands  
Amplifiers, JBL & Peavey  
Speakers, Yamaha FX'S.  
Transportation.

PLEASE PHONE:  
MARK WILLIAMS

ON (070) 518519  
OR FAX (070) 512979

## MUSIC GEAR

**Acoustic 150 watt** bass amp head, features 2 input, bright switch, power boost, travel mid & bass plus, 5 band graphic 70Hz to 2K effects loop incl. 2 model 404 speaker cabinets, 15in speaker in each, nearly new \$1500 (03) 315 9347

**Akal S1100 Sampler**, 8meg Ram & Scsi card, \$4500, with 32meg & Digital sampling card, \$6500 (03) 482 4970

**Akal X7000** sampling keyboard with 30 discs, \$500 or near offer. 0018 85 7102

**Alesis data disk** stores any kind of midi information from almost any midi device expands memory of sequencers, samplers, synth. etc. \$490 (03) 489 7069

**Alesis Quadraverb GT** effects processor, EC \$850 A.H. (03) 726 0338

**Alesis Quadraverb plus**, studio or live, good for reverb, chorus delay effects, can also sample \$695 (03) 347 9870

**Amplifier, Marshall 80 watt**, Valvestate combo, foot switch, must sell, \$750 or near offer (08) 239 0088 BH or (08) 396 3096 AH ask for Andrew

**Bass amplifier Trace Elliot AH200** Series 6 plus 8 x 10 speaker box \$1900 (08) 295 2528

**Bass amplifier, Marshall 60 watts**, with 15in speaker, excellent cond. \$600 or near offer (08) 265 3514

**Bass box, Marshall 1510**, 200 watt, 4 x 10in Celestions, mint condition \$500, also 2 unloaded bass boxes, suit 15in speakers, \$50 each (08) 263 1137

**Bass speaker cabinets** with 15in JBL K140 \$300 (03) 359 5486

**Boss effects pedals, PSM5 power supply** and master switch, with transformer, CE2 chorus, DMI analogue delay, Ibanez Super metal distortion, with hard case and patch leads, \$350 or near offer (08) 45 2521

**Digitech mdl DSP16** effect processor, 128 programs with separate EQ controls, EC \$500 (03) 735 0648

**Direct Injection Box - Frontline** Active D 1 Box, capable of running on phantom power \$90 (03) 489 7552

**Electronic Keyboard: Yamaha** YPP35, 1 Year old, touch sensitive, 8 voice recording capability \$450 or near offer. 077 715268

**Guitar Amplifier: Marshall** JCM900, 50 watt head & quad box \$1900 066 321 461

**Keyboard Kawai FS900: 100** Voices, touch sensitive, midi compatible, programmable with stand & sustain pedal \$1000 as new 071 515099

**Korg Sound Module: 03RW, VGC** \$1200 075 748475

**Marshall 50 watt combo, 70's JMP, 25 watt Celestions**, channel switch, sounds great, \$800 negotiable (08) 379 8214

**Marshall Amplif. 800 JCN Series**, 100W amp. & quadbox, split channel, less 12 mths old, as new, never had road use, can supply roadcases \$1990 lot (03) 357 3538

**Marshall JCM800 50 watt lead** series head, excellent condition \$595, Fender 12 string guitar with case, \$350. (08) 381 7956

**Marshall JCM900 quad. box, slant** front, \$700 (08) 333 0196

**Mesa Boogie Mk III 100 watt** head, excellent condition, \$1500 or near offer 018 81 8923 or (08) 43 3787

**Nady 101GT guitar link** in box \$350 BH (052)224099

**Roland KR-33: Digital piano/key-**board, plus MT100 digital sequencer & sound system \$1600 075 393247

**Zoom 9002 guitar effects** processor, 12 effects, \$300 (08) 294 6926 after 4.30p.m.

**Zoom 9030 advanced instruments** effects processor half rack size 47 effects EC \$900 (03) 419 3395

Classifieds cost \$9.60 for 10 words, thence 60c/word. Call (02) 876-3530

## Bass Player Wanted

Bass player wanted for Sydney industry 'old fart' R & B band comprised of people from Ramtek, Elecoustics, and The Audio Connection. (Danger, Ed) We want you as long as: • Playing in time and enjoying yourself is more important than ripping off Stanley Clark. • You have a bass guitar in the closet. • You have family and work commitments, but the gentle voice of Jack Bruce haunts you a t night. • Hopefully you are over 33 and want to recapture a lost chord of the past. • You somehow are connected with audio or sound in your work, but definitely want to keep your day job. • You are Ok about rehearsals which are not too serious leading to not too frequent gigs. Call Glenn now. (02) 799-6742.

**EMPLOYMENT** classified advertisements are FREE in Connections, Jobs wanted and Posn. Vacant. Send by Fax or post no later than the 25th. Fax (02) 876-5715, PO Box 439, Epping NSW 2121.

**ADELAIDE BASED PRODUCTION**

**GOLIGHT**

- JBL Modular Systems up to 16,000 Watts
- Composite Systems: R4 & Mongoose up to 4,000 Watts
- Perreaux & Australian Monitor Amps
- Active 3Way Sidefill/Drumfill FB up to 7,000 Watts
- 32 Channels FOH Top Quality
- Outboard Gear Crew, Rigging & Lights Available.

Contact: Tim Marshman  
12 Ruthven Avenue, Magill, SA 5072.  
Phone: (08) 31-2891  
Pager: 016 080 # 840 924  
Mobile: 018 080 894

# HOT ICE

## PRODUCTION SERVICES

**PROFESSIONAL SOUND REINFORCEMENT and LIGHTING SERVICE**

System A  
6,500W F.O.H 3,000W F.B. 6 SEND

System B  
3,500W F.O.H 3,000W F.B. 6 SEND

Ph: Mark Langfield  
(02) 608 1104  
015 216 985

## Electric Sunshine Lights Your Band Brighter. HERE'S PROOF

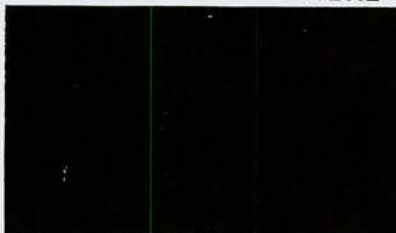

**BAND USING "BRAND X" LIGHTS**



**BAND USING ELECTRIC SUNSHINE LIGHTS**

DEMONSTRATION WITNESSED BY THE HOUSEWIVES ASSOCIATION OF N.S.W.

# MUSIC MI

## NEWS & UPDATE

### SHORT BITS

- According to Frontier Touring boss Michael Chugg, INXS came forth with a \$50,000 donation for the Bushfire Concert, held in February at Sydney Football Ground.

- DiMarzio have a new single coil pickup - the Blue Velvet DP170 and DP171 (Bridge). Hand built, says Australasian Music Supplies, call (03) 872-4488.

- The Musicians Placement Service in Sydney moved recently, the phone number is (02) 956-6281.

- FENDER say the Stratocaster has sold better than 1,500,000 units. Turning 40 in May, the thing is the most recognised guitar in the world today.

- With VRF's Melbourne Guitar Show just concluded as we print, the Australian Music Association are poised to announce a Melbourne Music Show of some type for later this year. This takes the place of a Brisbane event, favoured by some AMA members.

- DiMarzio say their new Sound Lines Guitar Cables are tough, and you can actually hear the difference. Now that's subjective! Call A.M.S. on (03) 872-4488.

- ARIA — the Australian Record Industry Association — say the total sales of CD's in Australia for 9 months January - September last year were 14,486,674 (+8% over '92) at an average wholesale cost of \$12.99. Cassettes were down 20% to 5,561,382 (at \$8.72 each) and poor old vinyl scraping the floor, 14,669 albums, down 42%. Meanwhile the pressing cost of a CD is about \$2 for a 1000 run.

### Ausmusic 'Stayin' Alive' Report - stage one ready REPORT RELEASED

The culmination of six months research into the music industry and reasons why declining opportunities are prevalent, is the Stayin' Alive project. The first phase, named 'Identify the problem' was released to an industry function in February, although the physical report was not available on the day due to compilation logistics.

Addressing the gathering were report consultant Cathy Howard, Ausmusic NSW head Marcella McAdam, and Ausmusic General Manager Sue Gillard - who said the report reveals something we've suspected all along. "In essence Rock & Roll is a black market, a grass roots market, and we're doing the best we can".



Ausmusic G.M. Sue Gillard

According to Ausmusic, an early result of the research is that the most effective form of promotion and advertising is word of mouth.

• Call Ausmusic for your report copy, a small fee applies. Syd: (02) 552-3232, or Melb: (03) 696-2422.

### SWR importer back from NAMM, ready to rev, but: Players Slow For SWR

"It'd take more than a 6.6 to keep me away from NAMM", said Kosmic Electronic Industries boss John Goldsmith, but "it was at least an interesting feeling rising at 5.00am WA time to ready for departure to LA, with the news (of the earthquake)".

SWR are the staple bass amp diet of many major acts in the USA, but tours downunder are demanding the product, says John. "The latest being Robyn Ford, using the new Interstella O/D released at NAMM".

"Oz Bass Players have been slow to catch on, perhaps re-arded by



Redhead - by SWR

the economic era".

New for SWR at NAMM are the Silverado Combo, a 100w 1x12" combo, and Henry the 4x8.

Call Kosmic for further details, (09) 242-3844.

### BUYERS GUIDE

#### SEQUENCERS

**Audio Production Midi Sequences** (03) 887 8127. **Midifiles** - GM/GS Midifiles \$16.00 Australian made, fully produced GM/GS midifiles for all modern equipment.

**Yamaha** (03) 699 2388. **QY8** Portable Music Sequencer. Portable music production system based on the original QY10, with lower price and a totally redesigned control surface inc. sequencer, tone generator and auto-accomp. capability. 8 track seq. with real time or step record. \$595

**QY20** Portable Music Sequencer. Portable music production system incorporating a sequencer, tone generator and auto-accompaniment capability. 8 track sequencer with real time or step record modes \$1095.00

**TG100** Tone Generator. Advanced Wave Memory architecture (AWM), General MIDI Level 1 compatible, 28-note polyphony with dynamic voice allocation, 192 instrument voices, 10 drum kits, comprehensive editing facilities reverb and delay \$695.00

**TG300** Tone Generator. AWM2, advanced digital filters, General MIDI Level 1 compatible, 6 MBytes waveform ROM, 32-note polyphony, 456 presets, 9 drum kits, 128 user voice presets, comp. editing facilities, 16 voice multi-timbral, programmable effects, built-in MIDI interface for Apple Mac and IBM PC. \$1495.00

**RM50** Rhythm Module. AWM2, advanced digital filters, int. waveform RAM expandable to 0.5 MByte, 16-note polyphony, 64 preset and 64 editable drum kits, 500 preset and 500 editable voices, 128 user voices, comp. editing facilities. \$1695.00

**TG500** Tone Generator. AWM2 advanced digital filters, 8 MBytes waveform ROM, waveform RAM expandable to 1 MByte, 64-note polyphony, 384 presets (incl. 252 voices, 4 drum kits and 128 per-

**Reviewed: Lexicon JAM MAN  
Roland S760 SAMPLER**

# BAND TALK : Gentle Persuasion

## Musical Description:

Acoustic/Electric Rock.

**Management:** Gary Moorhead Management (03) 387-8665 or (03) 696-2422.

**Agent:** Michael Newton, Premier.

**Sound Engineer:** Jonas B. Fader (ex Roxette, A-Ha)

**Crew:** Boaguana The Love Pirahna. (Know this guy?)

**GEAR: Guitars:** Lead-Fender Strat, Fender Twin, dig. delay, overdrive & stereo chorus effects pedals. Other- Maton 6 and 12 string through Jazz Chorus amp, Fender Telecaster, Music Man amp/

**Bass:** Fender Jazz, Ampeg SVT3 rig.

**Drums:** Pearl, Zildjian cymbals.

**Preferred Microphone:** Neumann Valve

**Fav. Music Store:** Drum City Prahan, "because they have the best gear, look after us, and are nice people".

**Fav. PA/Prod. Co:** Advanced Audio,



Gentle Persuasion Players (from left) Byron Chilcott drums, Tim McLean vocals/guitar, Chris Pierce Guitar/Vocals, Peter Haydon Bass/Trumpet

reason same as above!

**Crew:** Philip Jones & Grant Le Page.

**Gear Tips:** LOOK AFTER IT, get road cases for everything and INSURE!

Your band here—call Julius, (02) 876-2612 now.

## Buyers Guide Sequencers (cont)

formance combinations), editing facilities. \$2695.00.

**QY300** Music Production System. Workstation inc. a full-function sequencer and tone generator with DSP effects. 16-track, 10 song sequencer with 64-note polyphony (36 via MIDI) and new conductor track for auto-accompaniment and auto-harmonisation. New model - available in May 1994. \$1695.00.

**Emagic** from Electric Factory (03) 480 5988. Logic \$999.00 Object oriented midi sequencing and notation program for Mac and Atari, adv. window technology for flexibility, unlimited tracks and sequences, multiple editing options.

**Micrologic** \$499.00 Powerful entry level midi sequencing and notation software for PC, aimed at education and home users, object oriented.

**Notator SL** \$799.00 Midi sequencing and notation software for Atari ST, ST/E and Mega computers. 64 Tracks, 99 patterns, powerful integrated notation/midi event editing.

*NAMM the venue as US manufacturer turns up the heat on everyone, now Peavey do drums too!*

## Releases Staggering

Last year at a Peavey Dealers function I realised the American manufacturer were somewhat serious about expanding, having at that time just opened factory number 17 or some such number.

This year they continue to assault the M.I. (that is, Musical Instrument to you) market with an array of product releases across the board.

The drum kit I'm not so sure about, it is a new technology thing that Australis are better at describing— and I think my drummer jokes preclude me from addressing the drumming community.

**GUITAR AMPS:** More tweed covered all tube models, the Classic 100 has new 8EL84 output tubes, this is a head amp, while the Dual 2 x 12 is an all tube 120w twin with tremolo, vibrato and reverb for around A\$2300. There's more.

**BASS AMPS:** TMax is a 500w combo with either 1 x 15" or 2 x 10" speakers, while the KiloBass is fairly unique, two amps in one, one valve, the other solid state, and both 500w for 1000w total!

**EFFECTS:** TGX for guitar and BTX for bass, both in rack and floor mount, the TGX is actually a fully featured all-tube preamp with 12 x AX7's, with a digital effects unit that has 31 effect types and 256 patches. The SHOWFEX has 8 simultaneous effects from 35 effects types, can be patched any-which-way, and has balanced in and out's.

*Call the Peavey people down under: Australis in Sydney & NZ.*

### DEALERS TRECK TO MS

• Meanwhile as we print, a contingent of Australian and NZ Peavey dealers are at Peavey HQ, having won an incentive prize from the distributors, Australis.

The party were scheduled via Memphis, to enable a visit to Gracelands and some R & R before spending a working week in the new Peavey Educational Centre, were Pro Sound was on the agenda. A compulsory jam with the Peavey house band was threatened, then four days in LA on the way home. 17 souls made the trip.

# HECTIK

## Melbourne's Most Affordable Lighting Company!

We hire everything you'll ever need in lighting, from the basic smoke machine to the latest moving light technology.

TOURING SYSTEMS A SPECIALITY

AGENTS FOR LSC  EQUIPMENT

Call Tony:

Telephone: (03) 827 9036

Mobile: 018 378 047

Repairs & Installation of all Lighting Equipment, and Manufacture of COMPUTERLIGHT Patching Systems & Electronics by SJT Electronics

• THE SHARP • TOYOTA • KODAK •

# ELECTRIK

24 Wilson Street  
South Yarra 3141  
Victoria, Australia

# Review: Roland S760 SAMPLER



## Honey, I shrunk the sampler!

With all the fanfare now surrounding digital multi-track recorders the humble sampler has been relegated to second place in the newest and most exciting category and whilst the notions of sampling remain the same improvements are definitely being made. Taking a leaf from Peavey's excellent 1 rack unit high SP/SX models Roland have gone one step further squeezing both sampler and playback sections into a single unit shell.

Aesthetically the S-760 almost doesn't appear to be a Roland sampler, it's too small, what's happened to the QE-2's of the sampler world? Fear not, the rack eating models are still around, the S-760 fits into the range below the S-770. As small as it is, the S-760 still offers the vast array of functions synonymous with Rolands sampling concepts, in turn the instructions are divided into two books for basic and advanced categories.

The combination of an uncluttered front panel and the new display screen have certainly lead to improvements in the navigation area, while the back panel houses a SCSI connector, stereo/mono inputs and two pairs of stereo outputs that may also be configured as individual outputs. Though more outputs would have been nice the four provided should be enough if outputs are addressed correctly inside the patches created.

The suspiciously blank section of the rear panel, next to the SCSI port, is there in readiness for one of the more sensible optional extras we've seen lately. For the almost reasonable price of \$795 the S-760's "power sampling" option will give you digital in and out as well as allowing CRT screen and mouse connection. A very soothing thing for propellor heads, computer junkies and the visually impaired!

By using a method described as "Quick Sampling" we were able to create samples and their corresponding patches with relative

ease, more often than not just following directions from the different menus in the display. The faithfulness of reproduction was as you'd expect, what came out was what went in, and with six available sample rates the sample, or remaining, time can be used very effectively even with an unexpanded model.

After having sampled we took a wander through the edit pages of the display..... stop. Let's get this out so as to not keep hinting at the display, the black on yellow/green LCD display is by far one of the best front panel displays around. They get a lot of information into one screen without losing readability or creating unnecessary confusion thus eliminating excessive menu or page flipping, for a Roland this is a big step. Add to this the simple up/down/left/right cursor keys flanked by the increment/decrement keys with rotary value/menu (up/down) dial directly to their left and you will, as we did, realize that it is possible to now go FAST on a Roland sampler.

Anyway back to the editing, and this what it really comes down to, the S-760's editing functions are sooo comprehensive that to run through the whole thing would

almost constitute another magazine though one thing in particular stands out. Onboard two band digital EQ. Sit back and think for a moment what is possible with onboard EQ, even if only two band, and a myriad of editing functions..... get the picture, you can really pull some twisted samples especially in the "Loop" pages.

Commendations should go to Roland for the rethink of their operating system, navigation, and full tilt intergration design. To fully appreciate an S-760 one may want to look toward an expanded, optioned and CD-ROM or hard drive connected setup. Their operating system is suitably ready to handle much more than what you see on the front panel. During the short time we used this machine we could really only find one disturbing and (yet) unexplained thing, when playing back samples, factory or our own, we noticed a gating effect across the outputs that sometimes clicked as the sound closed out. What is it- it's driving us mad!?!

The Roland S-760 gets a big "well done" on most levels and for what this unit is capable of even the price isn't too offensive. Yes, well worth a look!  
RRP: \$4,495, Call ROLAND.

## Technology Explained Sequencers & Sound Modules

By Greg Simmons

Today's music and sound technologies incorporate vast amounts of digital electronics, and where there's digital electronics and music together in the same box you'll almost certainly find Midi. One of the most exciting things about Midi is its relentless evolution and propagation: it is continually re-defining old technologies and making its way into new ones.

Not only does Midi infiltrate and improve existing technologies, it also creates new ones. One of these is the sound module, the other is

the Midi sequencer. Two different pieces of technology that complement each other — one generates and plays sounds, the other records and plays back all the movements made on a keyboard or other Midi controller. As we'll see later, these two technologies are merging together. But first, let's take an individual look at each of them. (For readers unfamiliar with the world of Midi, it is worthwhile reading the box items 'A Quick Intro To Midi' and 'The  
(continues over)

## Buyers Guide Sequencers (cont)

**KORG** from Music Link Australia (03) 429 9299.

**/ 3 Interactive Workstation** \$4995.00 Advanced song-writing facilities with unique Backing Sequence mode. Interactive performance and arrangement. Incl. disk drive, SMF, high quality GM sounds, plus a 16-track sequencer.

**/ 2 Interactive Workstation** \$5995.00 As for / 3, with 76-note keyboard, and extra 2mB of PCM with Bosendorfer piano sample.

**01/W Pro "X"** \$8995 16 -Track sequencer with Music Workstation facilities, 88-note fully weighted piano-style keyboard, disk drive, SMF, pro features, 10mB of PCM samples.

**01/Wfd Music Workstation** \$4995.00 16-Track seq, disk drive, SMF facilities, professional sequencing features, Waveshaping synthesis, large LCD screen, twin multi-effects and more.

**X3 Music Workstation** \$3595.00 16-Track sequencer with SMF, full GM soundset, multi-effects, many user-friendly sequencing features, IBM/Atari compatible disk drive.

**Passport Designs** from Mainly Multitrac (03) 558 1155.  
**TRAX 2.0** - 64 Track MIDI Sequencer for Mac. Personal MIDI Recording System. 64 Track MIDI Sequencer, 16 MIDI Channels, on screen instrument field with mixer, with real-time recordable faders for volume. \$159.00

**TRAX 3.0** - 64 Track MIDI Sequencer for Windows PC, Personal MIDI Recording System. 64 Track MIDI Sequencer, 16 MIDI Channels, on screen instrument field with mixer with assignable faders, real-time recordable faders for volume and controller data. Quantize, Pitch Bend etc. \$265.00

**Master Tracks Pro** - 64 Track MIDI/SMPTE Sequencer for Mac and Windows, Personal MIDI Recording System with SMPTE facility. 64 Track MIDI Sequencer, 16 MIDI Channels, on screen instrument field with mixer with assignable faders, real-time recordable faders for volume and controller data. \$425.00

**MusicTime** - Desktop Composing and Notation for Mac & Windows PC. Desktop Composing and Notation Package with 6 staves and four voices per staff, full MIDI and step entry facility. \$459.00

**Encore** - Desktop Composing and Notation for Mac and Windows. Desktop Composing and Notation Package with 64 staves and eight voices per staff, full MIDI and step entry facility. Entry and Lyrics and other text elements, insertion of Guitar Chord Fret graphics which are transposable. \$1095.00

Meaning of Multi-Timbral', below right, before going any further.)

### SOUND MODULES

The typical Midi instrument has two components, known as the 'voices' and the 'controller'. Traditionally, a voice is a sound generating circuit capable of playing a single note at a time. It's common to find at least 16 voice circuits in a Midi instrument, allowing chords and complex polyphonic phrases to be played.

The controller is the device used to tell the voices which notes to play. The most typical controller is, of course, the keyboard. Other controllers include drum pads, Midi guitars and breath controllers.

Midi allows the voices of many different instruments to be played from a single controller. This means a musician can have numerous instruments connected together, and play them all from a single keyboard. The keyboards and controllers on the other instruments are never used. Some time back in the history of music

technology, a smart manufacturer had the idea of taking the voices from their most popular instruments and putting them into boxes without keyboards. Thus was born the sound module, saving studio space and manufacturing costs.

### Defining a sound module

The simple definition of a sound module is a Midi instrument without a built-in controller, such as a synth without a keyboard. A sound module can be rack mounting, free standing, or a card inserted into a PC, and requires Midi to operate. Some sound modules can also be used as Midi interfaces for personal computers.

A sound module is usually either a synthesiser or a device containing a number of PCM sounds which it replays. They are typically programmable machines that allow existing sounds to be edited and new sounds to be created using the internal circuitry. Note that you cannot record sounds from the outside world — that's the job of a sampler, and samplers are not sound modules.

Most sound modules are multi-timbral devices, meaning they can

play many different sounds at once (see 'The Meaning of Multi-Timbral'). A single sound module can be used to play an entire performance — drums, bass, keyboards, and so on — all controlled by Midi and heard via the audio outputs of the sound module. Not bad, eh?

### General Midi

One of Midi's great promises was the ability for musicians to exchange songs and musical ideas in the form of Midi song files (a Midi song file contains all the information necessary to play an entire song). A musician in Australia could save a Midi song file onto a floppy disk and send it to a musician in New Zealand, who could then play the song through their own Midi system and change it as desired. This is the musical equivalent of a writer sending a story to a magazine by putting it onto a floppy disk. The editor of the magazine is able to read the story on their word processor and edit it as required.

A word processor uses a standard set of characters (e.g. the alphabet), and the story on the  
*(continued over page)*

# BUYERS GUIDE

## SOUND MODULES

**Sansamp - Tech 21** from National Music Supplies 008 773 438

**GT2 PEDAL** \$449.00 SansAmp GT2 is a fast, easy and economical way to obtain pro quality tube amp sounds for recording and live applications.

**Classic Pedal** \$549.00 SansAmp Classic is a revolutionary tube amplifier emulator designed and engineered for recording direct and performing live.

**Bass C.I.** \$395.00 SansAmp Bass D.I. delivers quality tube amp sounds through user trimmable internal controls and XLR output.

**PSA-1** \$1500.00 SansAmp PSA-1, fully analog Tube Amplifier Emulator in a digitally programmable rackmount unit, 98 Virtual Tube Amp sounds.

**TRI-O.D.** (Avail. July) \$499.00. A Triple Channel Overdrive Stomp Box preset with three individually trimmable, classic tube amplifier emulations.

**Kawai** (Aust.) (02) 663 0571

**XS-1** \$399.00 128 Waveforms 4 Parts & Drums. 64 Single and 32 user patches. 16 Multipatch/ up to 4 singles layers, split etc. (Not G.M.)

**G-Mega LX** - XC3 \$699.00 160 Sounds (128 G.M.), & 32 Extra 7 drum kits, IBM, MAC, NEC interface with midi in and out, 28 note polyphony 16 part multi timbral external control.

**G-Mega** \$1199.00 32 Note Polyphony, addresses 32 midi channels, 32 parts, (G.M.) bank, special bank and user bank all fully programmable and editable. Mac interface.

**Q55** \$799.00 An easy to use direct to disc 16 track real time sequencer that reads and writes in Q55 or S.M.F. format. Records 16 tracks at once.

**Q80** \$1049.00 A sophisticated 32 track/32 midi-channel real time/step time extensive editing functions and data storage (Sysex), 26,000 notes.

**Q80EX** \$1499.00 Update of popular Q80 - Reads and writes S.M.F.'s and swaps between formats internally. 52,000 note capacity - can edit 3rd party S.M.F. discs.

**Q80 Upgrade Kit** \$549.00 A board replacement to bring the Q80 up to the Q80EX specifications. Installation at extra cost.

**Ensoniq**, from The Electric Factory (03) 480 5988

**SQ-R** \$1699.00. 32 Voice polyphonic, 8 part multi timbral, "smart

## VOCE: B3 IN A BOX

Another really handy new thing from NAMM is the VOCE micro B Hammond B3 simulator. The Hammond B3 Organ was the lump used by Deep Purple and numerous Aussie bands of the 1970's, like Bakery, Pirana and Sebastian Hardie. Great analogue sweeping sounds from a Leslie rotating speaker cabinet. Huge, heavy, but

unique of sound.

Now you get the sound in a half rack space MIDI module. A nonsense 32 note polyphonic synth that even has simulated upper and lower rotor that speeds up and slows down!

*Retails for \$1195, distributed by Kosmic Electronic Industries, call (09) 242-2344*

## AKAI MPC 3000

Akai say this is the world's greatest sampling drum machine, as well as the best professional sequencer for those who want an alternative to complex computer sequencers. The MPC 3000 will sell here for a hefty \$6500, which is OK for a solid live sequencer.

It has a 99 track sequencer, with 16 bit stereo sampling, 16 meg maximum RAM, dynamic filtering, digital sampling, 64 MIDI channel output, SCSI

and more. Previewed at NAMM, due later this year.

*Danny Dunn at Australis is the AKAI expert- (02) 938-3466.*



### The Meaning of Multi-Timbral

'Multi-timbral' refers to a Midi instrument's ability to play a number of different sounds at once. Most Midi instruments contain at least 16 voices, meaning they can play 16 notes simultaneously, or that they have '16 note polyphony'. Not all musical parts require 16 note polyphony, therefore some voices won't be necessary.

A bass guitar part may only require four note polyphony, so it will only need to use four voices. In a multi-timbral Midi instrument, the other 12 voices can be assigned to other sounds and used to play other musical parts, each part arriving on a different Midi channel. This allows a single Midi instrument to play all the parts of a song.

For example, a sound module with 24 voices might have eight voices assigned to drums and controlled via Midi channel 10. Four voices may be assigned to a bass sound controlled via Midi channel one, six voices may be assigned to a string sound controlled via Midi channel two, and so on until all the voices have been used.

# Review!

## Lexicon JAM MAN

No one actually suggested we review this product, it's just that we saw this one sitting in a rack at a local music store and wondered out loud "Anyone know what a Jam Man is?". The end result was the comment "You're the reviewers, you tell us!".

Most products have their model name inscribed on the front panel followed by sub-text announcing that the unit is a "delay effect" etc, this Lexicon unit, simply says "Jam Man"! The left side of the panel has three rotary controls Input, Mix and Output thus leaving the impression that it may be an effect unit. These are followed by some illuminated symbols combined with a two digit display either side of which is a 'Function' and a 'Reset/Bypass' button. Remaining is a single 'Tempo' LED,

a button labelled 'Tap' and two sixteen position controls; one for accessing the many modes and the other simply known as 'Select'. So...."anyone know what a Jam Man is?".

Aside from being pretty good fun, the Jam Man could seriously be the long awaited answer to a prickly problem. MIDI TEMPO MAP CREATION!! This device, as you play, can sample and loop audio according to a couple of footswitch entries and then output a pre-determined number of quarter note pulses to a MIDI device.

Let us start with the basic unit and get back to the ultimate example above as we progress. At first we set the unit to ECHO and, armed with the factory supplied two-way footswitch, we could

play guitar and by tapping the right-side switch twice "in-time" the Jam Man automatically delivered a delay of that tempo. In this simple mode the "Select" dial allows 16 choices of feedback, the left footswitch acts as bypass and the "Function" button on the panel lets you create delays that are 1/2, 1/3, or 1/4 the length of the time between foot actions. An obvious use is that you can tap your foot every bar as you slow down a song and the delay times will come with you! This in itself should interest many musicians.

Going up a level comes the units "sampler". This is basically a constant pitch, trigger play device and as such exists to support the next two levels of operation. You can, though, use the unit as a one shot sampler and it will play backwards: you can even change direction during the playback and this was, we admit, fun for creating audio "freak outs".

(continues over)

### Buyers Guide Sequencers (cont)

transmit" facility to control midi systems from splits and layers. Built-in FX, 80 performance resets.

**ASR10 Rack \$5595.00** 16 Bit stereo sampler, expandable to 16 meg, 31 voice polyphonic, 24 bit FX, fresample, sample or play external sounds thru FX, 8 part multi timbral, 8 outputs, SCS1 port standard.

**Alesis**, from The Electric Factory (03) 480 5988

**S4 Quadrasynth Rack \$2199**, 64 Note Polyphonic, 16 part multi timbral, 16 meg Waveform ROM, 128 factory resets, 128 user presets, QS Parallel matrix effects.

**Turtle Beach Systems** from Mainly Multitrac (03) 558 1155

**MultiSound Classic** - Hi Res Multimedia Sound Card for PC \$1345.00, 16-Bit CD Quality with Wavetable Synth and 44.1kHz 16Bit stereo recording capabilities. Card features; the famous EMU Proteus 1/SR sound Engine with 4 Meg of ROM based sampled sounds and MIDI In/Out/Thru.

**MultiSound Monterey** - Hi Res. Multimedia Sound Card for PC \$1145.00, As MultiSound Classic,

Don't even think about it! Connections **REVIEWS** are handled by *Bruce Waite & Dave Macken*, of Blind Lemon Pie. They **alone** decide what they will review, (and how) and are paid by Connections. It's got **NOTHING** to do with advertising in the magazine! Credibility rules.



PS10-F

You were shaken by the 'Earthquake', now get ready for the after shock.

**Cerwin-Vega!** announce one of their most important developments in professional speakers in forty years.

# ProStax

The new ProStax Series represents an entirely new generation of professional loudspeakers in terms of application.

ProStax MI and Install Series cabinets are compact and modular. All models share matching curved front profiles and each cabinet side has an inward angle of 15°. This provides for convenient multiple-cabinet coupling or handy cabinet stacking with ProStax's interlocking corners. All cabinets are made of 3/4" plywood covered with rugged Tolex™ vinyl with recessed moulded handles.

- MI Series available with pole mounting or stacking on subs.
- Installation/Concert Series available complete with flying points.

From the 10" 2xway system to the 18" folded horn cabinet - **ProStax** is for the professional.



PS-10

PS-12

PS-15



Exclusively Distributed Throughout Australia By: ASHTON ADMOR Pty. Ltd.  
34 Hargreaves Street, PO Box 305, Belmont, Western Australian 6104.  
Ph: (09) 478 3800 Fax: (09) 479 1941

Write in Reader Service number: 125

Finally a  
**RELIABLE™**  
 source of  
**HARDWARE**

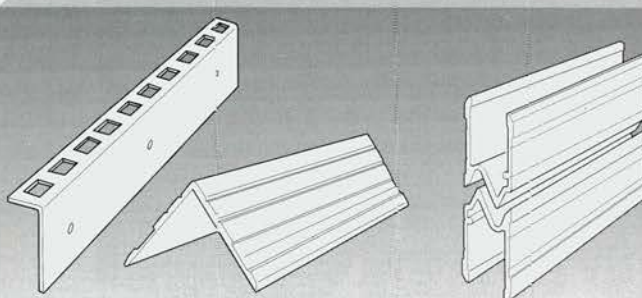
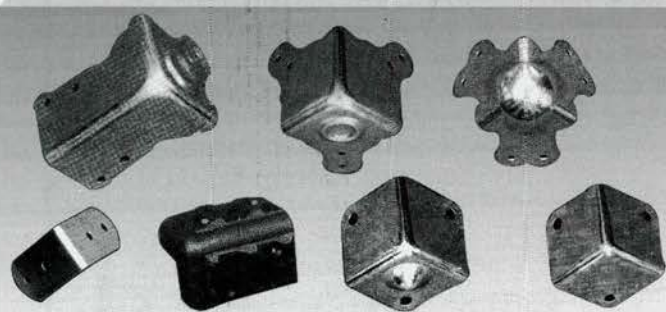
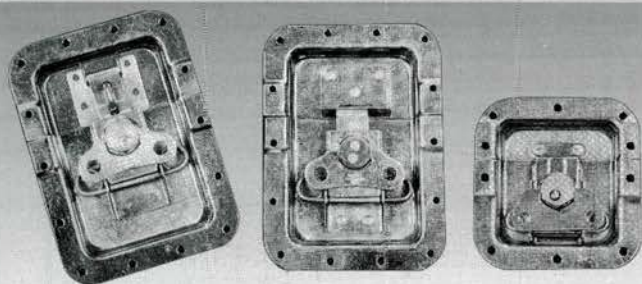

Please Ring (02) 516 3622 For a Brochure

ACN 001 187 837

**JANDS ELECTRONICS PTY LTD**

578 Princes Hwy., St. Peters, NSW 2044.  
 Phone: (02) 516 3622, Fax: (02) 517 1045



Write in Reader Service number: 114

**LEXICON JAM MAN** (Continued)

So we've made echo and we've made and played a sample this far. This takes care of two of the "Mode" dial positions and now the other fourteen are equally divided between the "Punch In Loop" and the "Phrased Loop" modes. The first loop mode lets you create a loop defined in length again by the footswitch timing. Until exhausting the internal memory you can overdub or insert over the original loop as many times as you wish. In this mode the left footswitch clears and re-arms the process. The Jam Man has an onboard memory of eight seconds at a fixed sampling rate, this can be upgraded by the user to thirty two seconds. The purchase of a second footswitch also allows control of "Select" and "Function" from the hands-free domain.

Finally, in this "Punch In Loop" mode your choice of the seven options determines the number of quarter notes sent to MIDI per loop. Subsequently you can leave

the unit set to "Replace" and play a song through it live while a sequencer creates a beat by beat map even if you only hit the footswitch up to every six bars. This occurs from bar one after you reach the end of your initial loop. Phrased Loop Mode is an alternative where you can create a loop and while hearing it repeat you can gear up for the following passage which can either replace this or add/after it.

In all it is a little hard to describe these higher levels of looping successfully on paper but we'd earnestly suggest that you investigate for yourselves. This Lexicon unit is quite unique and it certainly should find it's way into many of those situations where live musicians need to be the "sequence timing master" easily and without wanting to be burdened with boring "tempo track" mathematics. RRP \$1385.00 •

From Studio Connections, call (03) 723-4300

**SEQUENCERS & SOUND MODULES**

(Continued)

floppy disk simply tells the word processor where to put each letter on the page. With a word processor, the letter 'a' will always be the letter 'a', no matter what word processor it's read from — assuming we're using the same alphabet!

Midi song files are similar, in that they tell the Midi equipment what notes to play and when to play them. But unlike a word processor with its standard set of characters based on the alphabet, the original Midi specification didn't allow for any standard set of sounds — there was no sonic equivalent to the alphabet for Midi.

Going back to the earlier example, if the musician in New Zealand did not have the same sounds as the musician in Australia, they would not hear the same version of the original song. All the notes and timing would remain the same, but the actual sounds would be different. The bass drum part could end up being played with a trumpet sound!

This is like sending a word processor file written in English to someone in Greece — the basic structure would be the same, but the information would be meaningless because the document is

displayed with the characters of a different alphabet.

A solution to this problem was announced about three years ago, and is called the General Midi Specification. General Midi specifies what sound sources should be stored in what program numbers (memory locations), and forms a common alphabet for exchanging Midi song files. Each manufacturer is free to use whatever sounds they like, and store them in whatever program number they like. But when the sound module is put into General Midi mode, all the appropriate sounds must be found in the appropriate program numbers, in accordance with the General Midi Specification. This is done by a process known as 'tone mapping', which is beyond the scope of this story but is familiar to ex-

**PERTH M.U.  
 TECH FOCUS**

A Technology Focus Group is to be established by the Perth Musicians Union, to monitor technology as it affects the industry.

They would like interesting material, contact Peter Woodward, (09) 227-8172, fax (09) 227-9016.

Central Musical Instruments open QLD office, preview new NAMM offerings

## DOD, CMI, QLD

Just a year or so after taking on DOD/DIGITECH, C.M.I. have won a "Best New Distributor" award from the manufacturer. This capped a rather good trip to NAMM for Drago Trojkovic and NSW rep Billy Mawer.

CMI have opened a Queensland office staffed by John Raggett, who can be reached on (075) 799-992 or (018) 177-653. John came to CMI from James Music.

**NEW:** DOD have a cable tester, the DP-210 at \$110, an active DI Box (\$145), and Digital delay pedal with 4 seconds of sampling on the

way. DIGITECH have a new guitar signal processor, the GSP-2101, which combines a tube pre-amp with many processing features from the TSR-24.

Then there is the DHP-33 Digital Harmony Processor, retail estimated to be \$1699 and boasting intelligent harmony algorithms, delay to 1.5 seconds, pitch correction and 256 presets.

CMI also say they will have ROCKTRON International guitar endorser, Michael Angelo here soon for clinics. Contact CMI on (03) 315-2244.

SEQUENCERS & SOUND MODULES (Continued)

perienced Midi users.

The bottom line is that a Midi song file created in accordance with the General Midi specifications will sound almost the same on any Midi system that adheres to the General Midi Specification. This has opened up the market for mass production and sales of Midi song files, and some manufacturers are eagerly moving into it. A musician can buy a Midi song file, play it through their sound module, and hear it the way it was meant to sound. They can also change it in any way they want.

The General Midi Specification has 16 recommended set groupings for different types of sounds, covering the range of Midi program numbers from one to 128, e.g. program number one should contain the sound of an acoustic grand piano, while program number 128 should contain the sound of a gunshot.

Note that Roland have their own superset of the General Midi specification, known as 'GS Format',

### Buyers Guide Sequencers (cont)

but with own synthesiser. Synth has 4 Meg of ROM based samples, MIDI In/Out/Thru, a Real-Time effects processor for MIDI, and 'Sample Store' technology for playback of your own sound samples over MIDI (software included).

**MultiSound Tahiti** - Hi Res. Digital Audio Recording System for PC \$785.00, Digital Audio Capture Card. All MultiSound Classic features, less the synth. Synth can be added if req.

**RIO** - Pro. MIDI Synth Module for the PC \$645.00, Wavetable Synth Card with Sample Playback. RIO Synth has 4 Meg of ROM based samples, MIDI In/Out/Thru, Real-Time effects processor for MIDI, and 'Sample Store' technology for playback of your own sound samples over MIDI.

**MAUI** - Wavetable Synthesiser Upgrade for the IBM PC \$445.00, Wavetable Synth Card with Sample Playback. The MAUI Synth is a stand alone card, w/2 Meg of comp. ROM based samples, MIDI In/Out/Thru, 'Sample Store' technology for playback of your own samples over MIDI.

# Band Talk

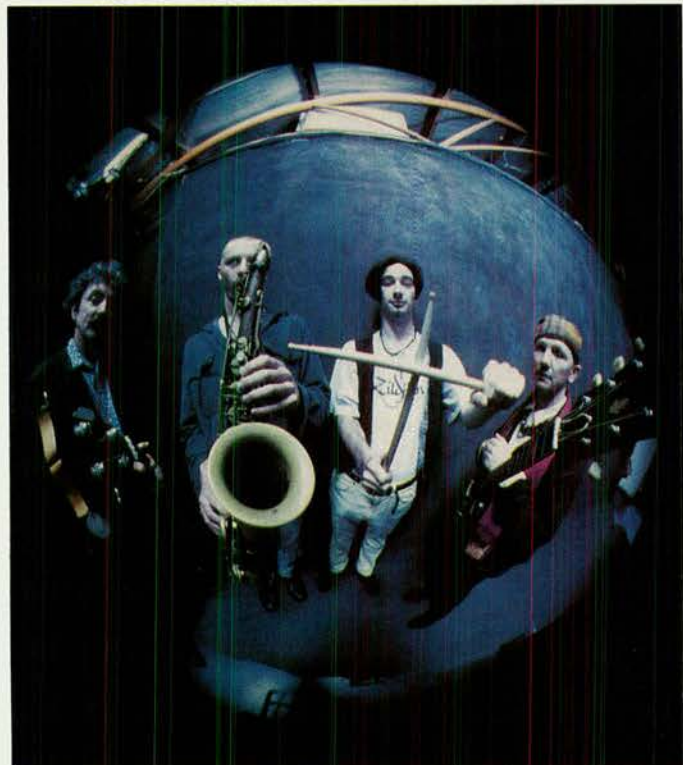

Steve Tallis And The Zombi Party can thank Steve Tallis himself for success to date .... "Persistence and a belief in what I'm doing".

**WORST GIG:** Yamchep Inn, 1983, spat on and abused for four hours.

**BEST GIG:** Bob Dylan support at the Entertainment Centre.

**TOURED SO FAR TO:** Paris, London, Germany and New York.

**PLANS:** Negotiating an Eastern States tour now,

looking forward to new audiences, SA, NSW & QLD.

**FAVOURITE Music Store**—Theo's, in Stirling Street Perth, because there is: "no bullshit, no sales hype".

**Fav. Production Co:** Audex, "the best in understanding a professional musician's needs - and best crew".

**Travel Agent:** Express Travel, Northbridge, WA.

**Players:** Steve Tallis *Vocal/Guitar*, Evan Jenkins *Drums*, Colin Atkins *Bass*, Carl Mackey *sax*.

## FEELING IS BELIEVING™



Foley  
Bassist for Arrested Development  
Live at Lollapalooza 1993

Using a  
Basic 350, Henry 8x8, Goliath II

Distributed in Australia  
By Kosmic Sound  
7/44 Hutton Street  
Osborne Park

Call for your nearest dealer  
Phone: (09) 242 3844  
Fax: (09) 444 1144



**SWR ENGINEERING INC.**  
The Finest Bass Systems In The World

Write in Reader Service number: 144

# The Ultimate Power Tool.



**Introducing CYBERLIGHT from Lightwave Research,  
The most powerful, most versatile, lighting tool available.**

If your lighting application demands the ultimate in Intelligent lighting, Lightwave Research has the Power Tool for the job. Cyberlight has been designed from the ground up as the most complete and powerful Intelligent lighting system available. Cyberlight has color mixing, fixed colors and upward, downward, and centered color correction for a rainbow of color possibilities. Rotating and fixed gobos with gobo mixing, lightning-fast shuttering, remote focus, variable frost and zoom provide a limitless variety of stunning looks. This power tool is also the most *Intelligent* light available, with a high speed

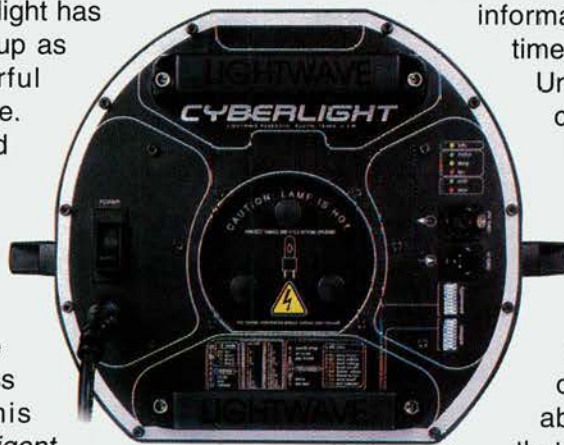

*Cyberlight is designed for the lighting professional with a rugged, roadworthy design, circuit breaker protection and easy access for service and carrying handles*

bidirectional data exchange that performs self diagnostics and transmits a wealth of operating information including elapsed operating time, lamp voltage, and lamp current. Under the control of our Status Cue console, Cyberlight is unsurpassed in its ability to deliver power and subtly quickly and efficiently. This allows you to concentrate on the creativity of your project, utilizing the myriad of live control options available. Not only is Cyberlight the utmost expression of lighting technology, but is affordable as well, and designed to stay that way.



**Engineered  
and  
Manufactured  
in the USA**

**GUVT**

82 Arthur Street  
Fortitude Valley QLD 4006  
Phone (07) 358-5022  
Fax (07) 358-4969  
Toll Free C08 773-187

**"The  
Science of  
Lighting"**

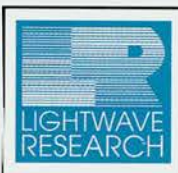

**GREATER UNION VILLAGE TECHNOLOGY**

WRITE IN READER SERVICE NUMBER 110

which significantly expands the scope of General Midi and has been adopted by many of the major Midi hardware and software companies. GS Format sound sources include all the standard General Midi features, plus additional parameters such as reverb and chorus effects.

### SEQUENCERS

Midi sequencers are the most inappropriately named items in the history of music technology. The term 'sequencer' dates back to the early days of analogue synthesizers, long before Midi existed. A sequencer, in the truest sense of the word, was a unit that made a synth play a repeating sequence of (typically) 8 to 16 notes, over and over again. But a Midi sequencer is a far cry from the analogue sequencer which it took its name from, and should really be called a 'Midi recorder'. Unlike the robotic 'step by step' feel of the analogue sequencer, a Midi sequencer is capable of capturing extremely small timing variations in the performance, and offers outstanding editing capabilities.

The majority of Midi sequencers use a tape recorder metaphor, with an on-screen representation of the

Midi information as a series of tracks, and controls that include stop, play, record, rewind, fast forward, etc. One of the most important things to understand about Midi sequencers is that they do not actually record any sounds. Instead, they record the information that tells the Midi instruments which sounds to play. Sounds can be edited and changed at any time by simply choosing another program on the Midi instrument, or by changing to a totally different instrument.

### Synchronisation

Midi sequencers become very powerful tools when synchronised to a multitrack tape recorder via SMPTE time code. It's possible to keep all the Midi sound sources under control of the sequencer, so they are never recorded onto multitrack tape. The only sounds that need to be recorded onto tape are those that are not Midi controlled, such as vocals and guitars. This minimises the amount of tape hiss (in an analogue system) and the total number of tape tracks required for the recording. Types of sequencer

There are three types of sequencer available. 'On-board' sequencers are those included as part of a Midi instrument, and are relatively lim-

ited. 'Dedicated sequencers' are stand-alone boxes designed for the sole purpose of recording, editing and replaying Midi information. These sequencers have all but been replaced by the 'software sequencers', which are actually computer programs requiring nothing more than a personal computer and a Midi interface. It's easy for the manufacture to add new features to a software sequencer, since all the controls and features exist as images on a computer screen — there's no hardware modifications required.

While software based sequencers are flexible and widespread, many Midi users would argue that you can't beat a well-designed dedicated sequencer for ease of operation and use. Although these machines all but died out a few years ago, they are making a comeback in a slightly different form, as described below.

### MERGING TECHNOLOGIES

Earlier in this story it was said that sound modules and sequencers are merging together. Yamaha's new devices are a good example of this merging. Described as 'Intelligent Assistants for Performance and Composition', these products incorporate a dedicated sequencer, a sound module, a drum machine, and numerous intelligent software capabilities to assist musicians in music performance and composition. No doubt other manufacturers have, or soon will have, similar equipment on offer. •

### A Quick Intro To Midi

*Midi is just another serial communications system, like RS232 or DMX512. A keyboard uses Midi to communicate with other digital musical instruments, telling them what sounds to use, what notes to play, when to play them, how loud to play them, and so on. One of the most important things to understand about Midi is that it does not contain any audio information — don't plug a Midi lead into a monitoring system and expect to hear music!*

*The Midi protocol has four different operating modes, each suited to a different application — from a simple two keyboard set-up to a complex system using a Midi sequencer and dozens of Midi devices. It also supports up to 16 different channels over a single lead, allowing all the devices in a Midi system to be connected in a simple 'daisy-chain' wiring configuration. Each device can be assigned to its own Midi channel and will only respond to information sent on that channel. •*

## HSR 700W AND HSR 400W

MOVING WITH PERFECT CONNECTIONS

OSRAM metal halide lamps with  
outer jacket protection

Lamp wattage	700W	400W
Luminous flux	58000lm	33000lm
Colour temperature	5600K	5600K
Average life	1000h	650h
Base	G 22	GX 9.5

INTELLIGENT LAMPS FOR INTELLIGENT LIGHTS

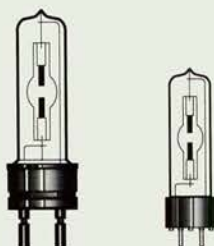

**OSRAM**  
TECHNOLOGY BROUGHT TO LIGHT

For further information or your nearest dealer call  
Wotan Lamps on 02 - 481 8399.

Write in Reader Service number: 157

### Buyers Guide Sequencers (cont)

**Audio Advantage** - PCMCIA Sound Device for the IBM PC \$345.00, Digital Audio Capture Card w/ MIDI interface for NoteBook style computer. Credit card sized sound card for use with NoteBook computers. Samples rates to 44.1 kHz 12-bit Mono & Dual Port MIDI Interface.

**WAVE** for Windows - Stereo Digital Audio Recording and Editing Software for the IBM PC \$245.00 Digital Audio Recording and Editing software for Windows PC. Full Stereo Audio editor for use with Multimedia comp. Sound Cards.

**Innovative Quality Software. SAW** Software Audio Workshop (4 Track Digital Audio recording and editing) for PC \$995.00. Recording and Editing software, full featured Multitrack Recorder Editor, with op's like Simult. Record and Play, Live Automated Non-Destructive Mixing, Realtime preview of DSP functions, Vari Pitch in tenths of a semitone, Non-Destructive Region & Play Sequence List Editing, SMPTE Sync & Generate capability.

**Korg**: Music Link (03) 429 9299  
**Audio Gallery AG-101** \$899.00, Comp. multi-media music package for Windows.GM sound module, MIDI interface, seq. and notation software, SMF play software and more. 32-Voice polyphonic, 16-way multi-timbral.

**Audio Gallery AG-102** \$899.00, Multi-media music package for Mac, with GM sound module, computer connections and MIDI interface, sequencing and sound editing software and more.

**05r/W** \$1499.00 Half-rack module with high-quality GM soundset. 236 Programs + 100 Combinations. 6 megabytes of PCM samples, 2 separate multi-effects (47 effects each), 32 voice polyphony, optional direct PC connect/MIDI interface.

**X3r Music Workstation** \$2999.00 2U rack-mount, with 336 Programs, 200 Copmbinations, GM compatible, 16-track battery-backed sequencer, disk drive, SMF facilities, data filer, 32 voice polyphony, 16-way multi-timbral, expandable with PCM ROM cards, two independant multi-effects units, switch/ alternate tunings, etc.

**Wavestation SR** \$2999.0, 1U rack-mount version of Korg's famous Wavestation, developed by ex-Sequential Circuits R & D team. 550 Performances on-board. Waveforms inc. acoustic instrum hundreds of synth samples -Prophet, Oberheim, Moog, PPG, etc. Incl. unique Wave Seq. and Advanced Vector Synthesis.

**NEXT MONTH:  
Backline AMPS!**

# WAREHOUSE NITECLUB *Profile*

Warehouse Niteclub in South Yarra, an affluent and cosmopolitan Melbourne suburb, is not a new venue but has recently upgraded its fitout and is now physically four times larger than its predecessor and caters to one of Melbourne's biggest club audiences.

The main room offers a large open dancefloor, which is underlit by mini-strobes and colour boxes. Overhead we find the Technofear Laser, Roboscans and hundreds of Pinspots. The main room also holds three Bars and a Mezzanine level for better viewing.

The Piano Bar offers a quite escape, with comfortable and private booths, where you can actually have a conversation, two cocktail bars and an intimate dance floor with an additional DJ delivering the soothing tones of Acid Jazz and Low Beat Dance music.

The Warehouse trades from Wednesday to Sunday inclusive and you can access it from both Daly or Clarendon Streets, South Yarra. Phone (03)826-8373.

**Owner:** The Love Machine Pty Ltd

**Venue Manager:** Nick Correale

**Venue Booker:** Martha Tsamis

**Lighting Design:** Lightamation

**Lighting Operator:** Aki

**Audio Design:** Sven Langebeck of Warehouse Sound

**Audio Operator:** Acting DJ's

**Video Screen Bank:** Peter Kemp of Coemar de Sisti Aust.

**Laser Design:** Mark Marshall of Technofear

**Laser Operator:** Dean Holland of Technofear

**Decor & Interior Design:** Tibor Hubay

**Entertainment:** DJ's; Live Bands;

**Floor shows:** Laser & Video Shows

**Typical Door Charge:** \$6 - \$10

**Theme Nights:**

Thursdays - Fluid, Progressive;

Fridays - Effect ,Funk;

Sundays - Marmalade ,Retro

## AUDIO

3 x Technics SL1200 Turntables

1 x Denon DN2000F CD Player

1 x Yamaha Cassette Deck

1 x Citronics Mixer

1 x Rane Mixer

8 x JBL Mid Bins and Horns in the Main Room plus 4 of each in the

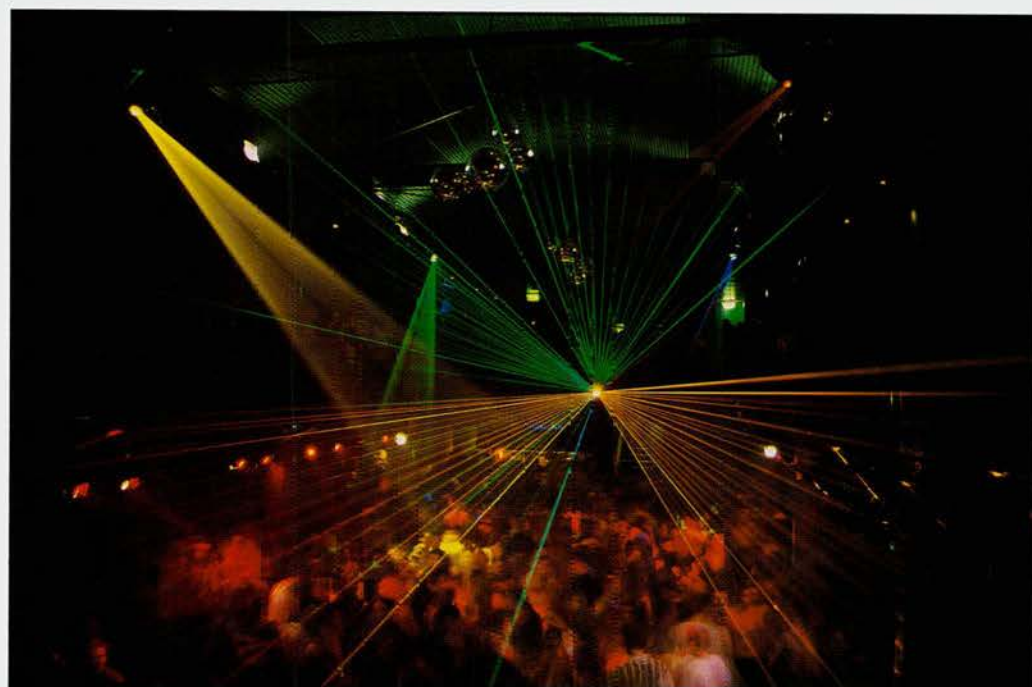

*Lasers feature at Warehouse*

## Piano Bar

4 x JBL 18" Bass Bins in the main room and 2 in the Piano Bar

Yamaha Amps, Crossovers & Compressor Limiters in the Main Room plus various other outboard equipment in the Piano Bar also available as technical backup for the main room.

## LIGHTING

### Main Room:

200 x Pinspots

4 x Roboscans

8 x Strobes

4 x Audience Blinders

16 x UV Tubes

Super Dancefloor:

72 x Programmable Strobes

183 x Programmable various coloured Light Boxes

6 x Various Chasing Neons

### Piano Bar:

4 x Roboscans

4 x Strobes

## LASERS

1 x Spectra Physics 168 mixed gas white light laser fitted with Technofear brand optics

1 x Technofear full colour 3D laser projector providing 16.7 million colours

1 x 30mtrs fibre optic

20 x assorted diffraction and outboard mirrors

1 x 10mtr by 10mtr translucent screen.

**DI-PRO**  
PROFESSIONAL MIXING CONSOLE

By **LEM**

- ◆ 16 sound sources
- ◆ 3 band Equaliser
- ◆ A/B Crossfade
- ◆ 3 Master Outputs
- ◆ Address a Sampler or effect from any channel

Available from  
**NOISEBOX ENTERTAINMENT SYSTEMS**  
(02) 890-1709

WRITE IN 147 ON SERVICE CARD

*Get Your Hands On This DJ Mixer*

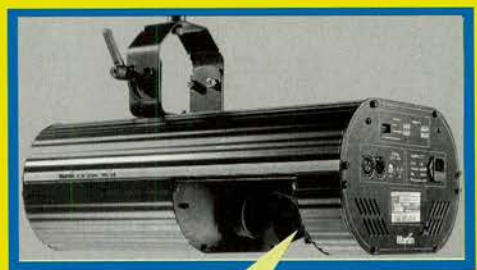

**DREW MUIRHEAD  
CORPORATION**

# QUALITY WITHOUT COMPROMISE

for HIRE of the world's latest lasers, intelligent lighting, disco effects and sound there is only one choice!



## AUSTRALIA'S HOME OF:

- Aquarius MK II Laser Systems
- Goldenscan "3" 1200 Touring Version
- Roboscan Pro 218 MkII plus 2032 & 2308 Controllers
- Emulators
- Theatrelight Desks
- Scan Command
- Robo Colours

- Gem ZR Series Smoke Machines
- Tiger NRG Rotating Gobo Effects
- Disco Effects - Clay Paky, Martin.
- SL 1200 Turntables
- Disco Mixers - Numark, Melos, Gemini.
- JBL 1400 Systems/Jands SR3000 Amps
- Rigging
- Par Cans



**Australia's most competitive HIRE rates available now!!!  
Ring Drew Muirhead for a quote today.**

dmc Lighting & Sound, 513A Elizabeth St, Surry Hills NSW 2010. Ph: (02) 319 7177 Fax: (02) 310 2685

**OPEN YOUR MIND WITH AUSTRALIA'S LARGEST INTELLIGENT LIGHTING COMPANY**

## ADVERTISERS INDEX

AIBA (MGA Bates)	33
Amber Technology	50, 60
AMID	52
Anything Audio	40
AR Audio	63
ARX	12
Ashton Admor	79
Audio & Recording Aust.	11
Aust. Audio Supplies	61
Australian Monitor	67
Australis Music Group	64
AWA	32
Bytecraft	58
CMC	17
Concert Lighting Systems	54
Coemar De Sisti Aust.	87
dmc	85
East Coast Audio	13, 51
Grafton Sound & Lighting	59
GUVT (Highend Systems)	82
Hectik Elektrik	77
Jands	2, 19, 27, 49, 80
Kosmic Sound & Lighting	81
Lightmoves Technology	25
Lots of Watts	57
Magna Systems	66
Mark IV Audio Aust.	4
Multicom	35, 39
Multicontact	15
Noisebox Entertainment	84
Paradise Recordings	42
Penn Fabrication Aust.	20
Prod. Audio Services	14
Rockard Paint	69
Rosco/CCCT	10
School of Audio Engineering	9
Selecon NZ	55
Showcraft	31
Show Technology	22, 23, 30, 88
Sontec Victoria / Bose	65
Southbank Trading	31
Studio Supplies	48
Syntec International	3
Tascam / AVD	37
Universal Lighting & Audio	6
Wotan Lamps	83
Yamaha Aust.	21

**READER SERVICE CARD:**  
You can obtain information on Products and Services in this magazine where a reader Service Number is indicated. Just fill out the **FREEPOST** Reader Service Card elsewhere in the magazine, and send it to us. Post FREE!

## WE NEED CAR TRASHING YARNS!

Bruce & Julius plan a yarn about trashing cars and trucks. Send or call with yours now!  
Fax (02) 876-5715  
or mail to PO Box 439, Epping  
NSW 2121 Australia.

# THE PA PAGE

## CHECKING USED SPEAKERS ....

Extreme care needs to be taken when buying secondhand speakers. The most important thing to do is LISTEN to them!

Start by removing the front grille and carefully inspect all speaker cones for any sign of "watermark" (where they have been wet) or tears and rips. Check that the dustcover (the dome in the middle) is in place and has not been pushed in by some dopy finger. Check the foam cone support around the outer edge for cracking or tearing. Most larger speakers can be "refoamed" for a minimal charge- but remember to "beat the price down" if you find a foam surround damaged. Be extra wary of Bose "Series One" 802's (made around 1980). These used a foam surround that weakens with time, and will eventually need refoaming at considerable cost, since there's eight drivers per box.

On larger speakers (greater than 8 inch), with all fingers evenly placed around the cone, gently push the cone in slightly and out again and listen for any scraping sounds, which are a definite sign of problems. Use your nose (yes, all senses are required in this business!) to sniff around the centre of the cone, as well as inside any horns. Smells of burning paper or plastic are danger signs.

Now connect the speaker up to an appropriately powered amplifier. Start first by playing very soft music through the speaker and put your ear up very close to each driver in turn, listening carefully for scraping sounds or "snuffled" distortion sounds. Jiggle the plugs at the back and check for loose connections. Finally, wind up the level and check the system at normal sound levels. The best music to use is something with a strong and clean bass beat and hi-hat, and little else. Heavy metal will not help you evaluate the quality of a second hand P.A. speaker.

After purchase, it is good advice to remove the drivers from their box once you get them "home" and check for loose connections, which can be easily fixed with a soldering iron. Check also that the connectors are fully compatible with the system you use (consider the various methods in use for wiring 3 pin XLR plugs) and if not, then rewire them. Check also for possible damaged crossover components, such as capacitors or coils which have been "Hot". This is usually a sign that at some time in the past, the unit has been connected to an amplifier that had no protection and went 'DC' during a show...

Paul Matthews, Matthews Audio Co.

## CHOOSING MICROPHONES ...

A beginner's mic collection or "kit" normally starts with 12 mics and 2 D.I.s or "Direct Input" boxes.

Often your system will be judged purely on how much "punch" it has—so you will need a good kick drum mic. Industry standard in recent years has been the Beyer M88, there are plenty of other types that will do the job nicely. The AKG D12 was the standard for nearly 30 years, other alternatives are a Sennheiser 421 or the Electrovoice RE20.

You may get away with cheap instruments and tom mics, but you can rarely do this with vocal mics. Skimp on the former if it improves the later. The Shure SM58 is the most widely used and preferred in this range and with price drops in recent years, it has never been more affordable. A few years back, I used Electrovoice PL80s with, I thought, good results, although they were subject to market resistance. Even though they were more expensive, singers would walk in, look at them and groan "Couldn't you afford 58s?"

When buying mics second hand, always insist on a demonstration. This needn't involve setting up a PA in some guy's lounge room. Most cassette decks have microphone inputs. By taking along your own XLR to jack lead you can easily compare the mic you're buying to one of your own that you know works as it should. Simply plug the mic in, set the cassette deck to record/pause mode and slowly wind up the record level. Even if his hi-fi isn't set up all you need is a pair of headphones. Don't annoy the guy with extensive A/B testing. All mics are slightly different.

If the mic you are buying is faulty, it will be obvious straight away, usually with severely diminished bass response. Often this means the mic has been dropped and the diaphragm is jammed. This generally means a new cartridge, which may cost more to have installed than the mic is worth.

Sometimes, however, diminished bass can be remedied by carefully exposing the diaphragm and very carefully removing any tiny metal splinters which may be pinning it down. To do this you will need non-magnetic tweezers; plastic or brass. Steel tweezers will clunk onto the magnet under the diaphragm, causing even more, perhaps irreparable, damage. While we're on the subject, at the end of each gig, ALWAYS take your mics from their stands directly into your mics case. Many people will lay them in a pile on the stage till the mics case is brought out and this is where they can pick up steel splinters that may be lodged in the carpet. This is also a valid reason for getting annoyed when singers place your mics on the stage instead of the stand.

Michael Orland, The Public Address Company.

## NEXT MONTH: Buyers Guides

**PRO AUDIO:** EQ's, Crossovers, Limiters, Signal Processors.

**LIGHTING:** Rigging, Trussing, Flying Gear

**MUSIC:** Backline Amplifiers

**Deadline 15th March**

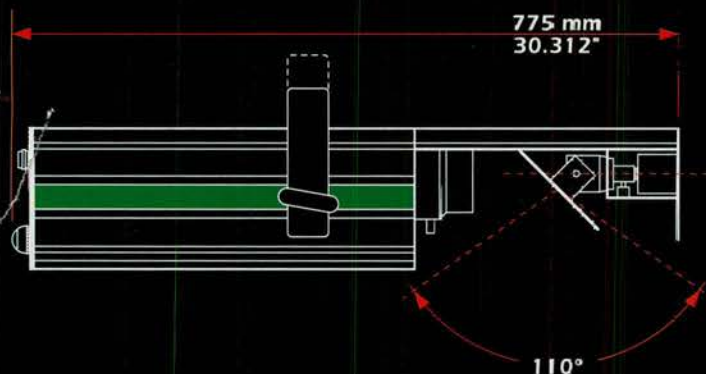

# micro scan 2

## 575 MSR



- 10 colours internal colour changer (9 dichroics + white)
- rotocolour effect (colours in continuous rotation) at 3 speeds (slow, medium, high)
- rotogobo effect (gobos in continuous rotation) at 3 speeds
- 10 gobos (5 interchangeable)
- adjustable strobing effect
- black-out
- programmable chase effect
- beam movement on X and Y axis\* achieved by micro-stepper motors
- DMX 512 or special input via 3 pin cannon (6 channels)
- 0/+10V dc input via 8 pin (6 channels)
- dip-switches for address number projector
- self-test and signal reception indicator incorporated
- digital signal for lamp on/off function including disable option
- can be operated in any position
- forced ventilation
- protection range IP20
- high quality optical condenser, formed by 1 high reflection spherical mirror, one parabolic lens and one plano-convex lens
- objective: 1 fixed plano-convex lens and 1 high definition focousable lens
- beam angle: 9°
- typical throw distance: 4-21 mt
- weight: 11,6 Kg/25,5 Lbs
- external ballast
- ballast weight: 8,6 Kg/ 18,8 Lbs (230V) / 15,8 Kg/ 34,7 Lbs (115V)
- GX 9,5 ceramic lamp holder
- long life Philips 575 MSR lamp: 750 h;
- power requirement 4,2 A at 230 V - 8,4 A at 115 V
- cable in compliance with the safety norms IEC 331, IEC 332 3C, CEI 20 35 2 core 1,5Ø + earth
- mains 115/230 V ± 10% 50/60 Hz (on application)

## macro-power in a micro-package

code 4231 micro scan 2 575 MSR (230 V)

code 4231/1 micro scan 2 575 MSR (115 V)

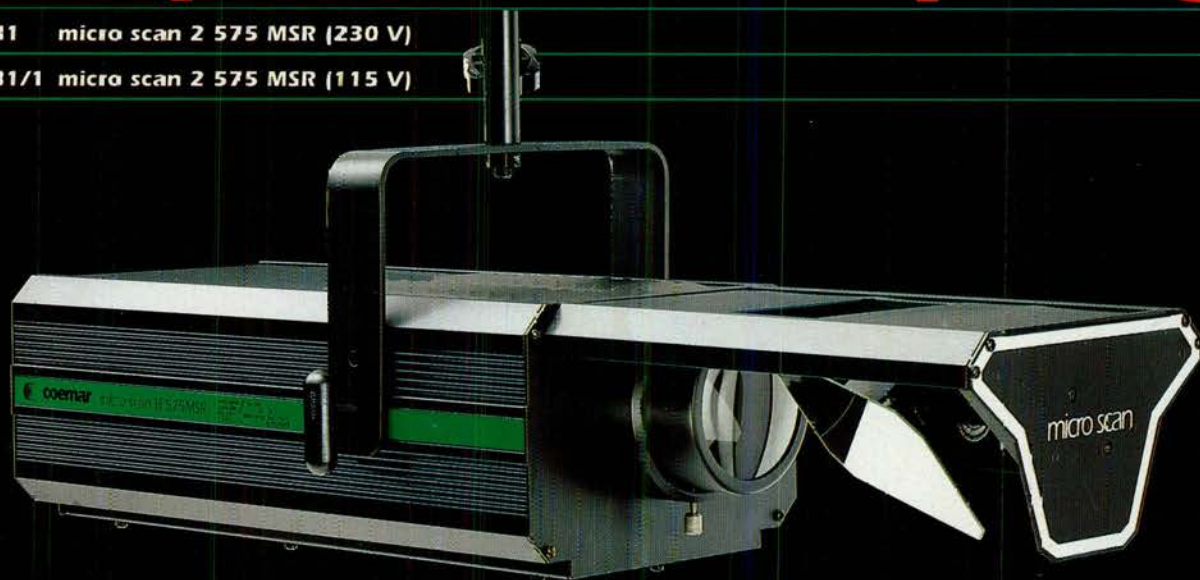

Coemar DeSisti Australia Pty Ltd  
 36a Clements Ave  
 Bundoora 3083 VIC  
 Ph (03) 467-8666  
 Fax (03) 467-8667



# coemar

# SHADOW: Follow...the future.

Most new products are developed from old ones. SHADOW followspots are not. The SHADOW range is a revolutionary new concept in followspots, incorporating the very latest technology to satisfy the needs of the most demanding users.

**SHADOW brings you:** • perfected traditional followspot performance • a wider range of features • improved precision and speed • automatic functioning • simplified operation • limited possibility of operator error.

And, of course, SHADOW followspots are powerful, robust, reliable and easy to transport.

- Available in **Short Throw** or **Long Throw** • Electronically controlled functions • Osram HMI 1200 discharge lamp • Exceptional light output • Twin condenser optical system with special anti-reflection lenses • Wide angle lens (standard for LT version, optional for ST version) • 0 to 100 % linear mechanical dimmer • Variable speed iris • Focus control (manual)
- Adjustable frequency strobe, 1 to 7 flashes/second
- 8 standard colours with colour wheel and ultra-pure dichroic filters • 2 conversion filters for further 16 derived colours
- 3200 K, 5600 K and 6000 K colour temperature adjustment • Bi-colour beams and variable speed colour wheel rotation • Rainbow effect
- Built-in power supply and power factor correction • Lamp hour meter • DMX 512, RS 232 (PMX) and Analog control inputs.



**DMX Followspot!**

All functions of **SHADOW** followspots can be **remotely controlled** from any desk or locally from their built-in **control panel** which can be mounted behind or alongside the unit. More than one SHADOW unit can be controlled simultaneously with individual or parallel addressing.

*Distributor for Australia:*

**SHOW TECHNOLOGY AUSTRALIA PTY LTD**  
13 - 15 Bridge Street - Rydalmere NSW 2116

Phone (02) 898 1111 - Free Call (1-800) 64 6666 - Fax (02) 898 1222

*Head Office:*

**CLAY PAKY SPA** - Via Giovanni Pascoli, 1  
24066 PEDRENGO (Bergamo) Italy

Tel. 39 - (0) 35.663965 - Fax 39 - (0) 35.665976



PROFESSIONAL SHOW LIGHTING

Write in Reader Service number: 153