

Connections

MARCH 2000 A\$5.00

ENTECH
2000

LATE FINAL EXTRA

AT THE SHOW

BIG HIRE & PRODUCTION DIRECTORY
JACKSON BRINGS i4 PA HERE FOR STREISAND
\$10,000 FOR 24 TRACK HDR? HERE!
LX DESKS UNDER 12 GRAND
PAGES OF NEW AUDIO FROM NAMM
IN THE TV STUDIO WITH HI-5
ON THE ROAD WITH BIG DAY OUT
LAST MONTH'S SESSIONS: 50 STUDIOS

Pro Audio, Lighting & Staging monthly

• New Zealand \$6.50 • Malaysia 36r
• Thai 2500bt • Singapore \$10
• Hong Kong \$45 • Philippine 240ps
• Elsewhere US\$7

ISSN 1320-5595



Print Post approved: PP255003/007511
Published and printed in Australia

**You Love Her
For Her Live
Performance.**

Marie Wilson

Marie Wilson with her Beta 58A microphone.



**She Loves
Shure
Beta Microphones
For The Same
Reason.**



SHURE®

Distributed in Australia by:
JANDS Electronics Pty Ltd
40 Kent Road Mascot NSW 2020
Phone: (02) 9582 0909
Fax: (02) 9582 0999

UNRIVALED PERFORMANCE!

Unrivaled Product Selection.

No other professional speaker series offers you as many choices. With 18 unique speaker designs, there's an SR-X System that's just right for your musical and personal style.

Unrivaled Reliability.

With the highest sensitivity and lowest power compression in their class, all SR-X Series speakers play louder longer.

Unrivaled Build Quality.

Their 13-ply baltic birch cabinets, virtually indestructible DuraFlex™ finish and tongue and groove construction are just a few of the reasons your SR-X system will gracefully shrug off the effects of life on the road.

Unrivaled Testing Ensures You of Unrivaled Satisfaction.

No other comparable system is tested like an SR-X. While most manufacturers test their speakers for only a few minutes, each SR-X design is tested for 100 hours at rated power output. This subjects SR-X to more strain and stress than they would typically experience in years of actual use! It's a JBL commitment that assures you unparalleled confidence and satisfaction.

Unrivaled JBL Technical Superiority.

Pure Titanium Diaphragm Compression Drivers in all two-way and three-way models assures you of superior power handling and reliability. **VGC™ Vented Gap Cooling** means transducers that control heat build-up. The result: increased power handling and decreased power compression. **Dual Mode Crossovers** provide total system flexibility. Switch from full-range to bi-amplified operation smoothly and effortlessly. **Optimized Aperture™ Horns** feature driver exit and throat flare that integrate seamlessly. As a result, SR-X Series speakers minimize throat distortion and provide smooth frequency response, even at the highest SPLs.



Add it all up, and you'll know why 9 out of 10 speaker systems travelling with today's top touring artists feature:
JBL's Concert Proven Components



H A Harman International Company



Meyer Sound



Bands, Blues, Boardrooms, Concerts, Conversion
Centres, Hotels, Hip Hop, Jazz, Malls, Music
Presentations, Production Companies, Quartets
Roll, Soloists, Theatres, Trios, and



Self Powered Ultra Series
Affordable performance

ns, Clubs, Dances, Discos, Duos, Function
, Night Clubs, Opera, Orchestras, Parties,
, Quintets, R&B, Rave, Restaurants, Rock &
anywhere else quality audio is required.

Meyer Sound Australia Pty Ltd

<http://meyersound.com.au>
australia@meyersound.com

Toll Free from Australia

1 800 4 MEYER

Toll Free from New Zealand

0 800 3 MEYER

projection // communications // events // I.T. // integration // techniques

PRESENTTECH

Australia A\$6.00 • NZ \$8.00 inc. GST • Singapore S\$10 • Malaysia 60 R • Elsewhere US\$10

Feb - April 2000



The Perfect Projector!
4 DV camcorders tested
Inside an MBA Presentations class

OUT NOW!
Call 1-800-635-514
for a subscription

**MAKING A
CORPORATE VIDEO**

ISSN 1442-7311



04



9 771442 731005
Print post approved: PP255003/04574

ENTECH

Sydney Showground & Exhibition
Complex, Homebush Bay
SUN 5, MON 6, TUE 7 MARCH

The Biggest AV Tradeshow

CONTENTS

The Entertainment & Presentation Technology monthly. Number 74, March 2000



Sony's 'Son of Oxford' - 40 grand! Page 20



MDM killer. Enter the HDR. Page 38



LX Desks under 12 grand. We profile them! Page 54

Streisand brings home Bruce Jackson	9
DSP changes name, attracts expansion funds, moves to LA	10
BigPond cable modem charges go crazy - 3500% rise 'not an error!'	10
Crown, EAW sold off	11
NAMM - the first new audio trade show of the new decade. Report:	11
Denon debut new flagship DJ CD deck	14
Shure intro new in ear monitoring system	15
Yamaha introduce new 16 track, 24 bit digital audio workstation	16
Allen & Heath introduce flagship live sound console	18
Son Of Oxford: Sony show dazzling new digital console	20
Long audio days at Hi-5	24
Saturated Fry: Duncan in search of the fast food holy grail	26
Letters	28
Bad Acoustics: how Barbra Streisand's crew are set to beat atrocious Football Stadium acoustics	30
Matho's audio theory - speaker cables - the final word	34
Studio special: how the MDM revolution has now ended. Enter the HDR!	38
Tascam debut MX-2424	41
BASF Tracking Guide	41
Mackie HDR and Tascam MX 2424 - side by side	44
Hire & Production Directory: giant, huge, very useful!	47
Gadget Grab Bag:	68
How to do it! Tom Misner's studio guide	70
How to do it! Duncan Fry's live sound guide	73
LIVE	
Staging The Allan Border Medal an inaugural event for Australian Cricket	p73
Australia Day 2000 loading up a barge on Darling Harbour	p76
Utopia Now a 12 hour show in Hong Kong	p78
The Big Day Out a production manager recovers	p80
Foo Fighters taking it easy	p85
LIGHTING	
Red Hot Chili Peppers small but innovative	p92
Lighting Control Desks under \$12,000 what is available today?	p94
Graphics Projection in a Digital Age Get it right	p104
Circular Quay Railway Station Lit Up a marketing solution	p106
Living The High Life dance lighting designer Allan Parkinson in profile	p111

SUBSCRIBE NOW- save \$\$\$ and get your copy FASTER!

Connections

Connections Publishing Pty Ltd Established in 1992 (ACN 058443182)

PHONE: 1-800-635-514 free (in Australia) or +61 2 9876-3530, OR FAX: +61 2 9876-5715, or post: FreePost 9, PO BOX 439, EPPING NSW 2121 Australia.

I'm a **new subscriber!** Make sure you send the magazine ON TIME EVERY MONTH - OR ELSE!

This is a **gift subscription!** Send it **WITH A CARD** saying it is from ME! My name is: _____

My phone: _____

Subscriber's name _____

Organisation _____

Street _____

Suburb _____ City _____

Postcode/ZIP _____ State _____

Country _____ Phone _____

Chq/draft/m.order A\$ Bankcard Visa

Mastercard Amer.Express Diners

Card No: _____

Expiry Date: _____

Cardholders Name: _____

Signature: *X* _____

UNLIKE other publishers, we DO NOT sell your details to other marketers! They remain CONFIDENTIAL.

Save up to 25%

AUSTRALIA (inc GST)

12 mths for \$48.00

24 mths for \$79.00

AIR MAIL

A\$80, N.Z., 1 year

A\$140, N.Z., 2 years

A\$80 ASIA, 1 year

A\$140 ASIA, 2 years

A\$115 USA, 1 year

A\$199 USA, 2 years

A\$125 EURO, 1 yr

A\$240 EURO, 2 yrs

Subscribers save 10% on all book purchases from us!



Separate Yourself.

With the new Roland V-Mixing System, your producers will stand out from the crowd, thanks to the world's first affordable separate console/processor design and up to 94 channels of digital mixing with 16 stereo (32 mono) channels of effects.

This revolutionary system lets you connect the motorised-fader console up to 200 metres from the rack-mounted processor/audio I/O box using two standard AES/EBU cables—eliminating the need for expensive, cumbersome audio snakes between the stage and mixing console or the studio and control room.

The V-Mixing System also gives you up to 88 XLR inputs or 48 channels of ADAT®/Tascam® communication, 94 DSP blocks, 5.1 Surround mixing, full automation and ever COSM Speaker Modeling capabilities.

Stop by Roland Er.tech Stand# 016 to check out the professional V-Mixing System, the compact and affordable V-Mixing Stations, the VSR-880 Digital Studio Recorder, the new DS-90 24-bit Digital Reference Monitors and much more.



Roland®

Roland Australia, 38 Campbell Avenue, Dee Why West, NSW 2099
 Phone: (02) 9982 8266 Fax: (02) 9981 1875 Roland website: www.rolandus.com

The new DS-90 24-bit Digital Reference Monitors' superb flat-frequency response, amazing sound quality and compatibility with COSM Speaker Modeling make them the perfect nearfield monitors for your digital or analog studio.



Connections

ENTERTAINMENT TECHNOLOGY ~ MARCH 2000

Welcome to Show Days!

It's no accident that this issue is released on Sunday March 5th - at ENTECH in Sydney. We've added circulation so we can give this copy - free - to anyone at The Show.

This month's magazine went in the mail on Friday March 3rd, to arrive as ENTECH ends. It goes on sale on Wednesday March 8, the day after ENTECH.

So we haven't overburdened it with ENTECH preview material, this mainly appeared in the February issue, along with the Show Guide.

There's a few last minute news items and fixups herein, but mainly this issue is business as usual, with news from around the region.

We've got over 24,000 readers, based on an average issue getting through 2 pairs of hands. So we'll only see some of you at ENTECH, while the rest of you get about your average week's work.

The other thing to say about this, the fifth ENTECH, is that it has grown a new sub-industry, with the addition of 35 exhibitors from the Presentations and Audio Visual industry. These stands are all located at the end of the main aisle - and some of the displays are eye boggling, judging from the plans we've seen.

Connections also has grown a magazine around the Presentations industry - and we will be giving PRESENTECH away free at the show.

If you didn't get to ENTECH, there's always 2002, when the show once again returns to Sydney.

Read about it next month.



STREISAND HERE FOR BIGGEST SHOWS

Sydney Olympics audio director Bruce Jackson returns to face acoustical challenge

The man chosen with the responsibility as Audio Director for the Sydney 2000 Olympic Games, Bruce Jackson, is set to return home early for another milestone event, the first Australian Barbra Streisand concerts in Sydney and Melbourne.

Bruce Jackson, an Emmy award winning sound designer for Barbra Streisand is looking forward to "the homecoming" and the four Australian concerts, possibly the last of Ms Streisand's illustrious career.

The Australian born Los Angeles based sound engineer has worked closely with Barbra Streisand in the 90s, Bruce Springsreen in the 80s and Elvis Presley in the 70s.

Streisand has described

Jackson as the best sound engineer in the world. He has been purely responsible for pioneering the high quality stadium sound for the Streisand and Springsteen stadium tours.

Show acoustics a challenge

• See page 30

Jackson said, "Before, people used to go in there, and throw up a bunch of speakers. We took a lot of extra time and did very sophisticated delay systems."

Jackson's long-standing experience with stadiums around the world saw him appointed as Audio Director for Sydney 2000

Olympics Opening and Closing ceremonies.

The sound engineer's journey to success is an amazing story.

At only 18 years old, Jackson and Channel Nine's current technical planner Phil Story founded Jands Production Company in Sydney in 1968. Jands stands for J for Jackson and S for Story meaning J and S.

Jackson's next company, Apogee Electronics developed UV22, a process to make CDs sound better, by adding silent information that carries all the fine detail. Apogee pioneered digital audio and created filters, which made digital sound warmer.

At 22 the young Australian reached one of the pinnacles of

(continues on page 30)

DSP attracts venture capital to fund expansion, changes name

Sydney Audio Post manufacturer moves HQ to LA, hires new CEO, flags increased competition

Digital Studio Processing Pty Ltd is now DSP Media, having successfully closed a venture capital deal and relocated its HQ to Los Angeles.

The capital deal is with Momentum Ventures Limited, and will fund future growth and expansion.

DSP was originally founded in 1991 and produces a range of integrated audio post-production systems that are designed for speed of operation with a combination of dedicated controls and touch screen interfaces.

Based in Sydney, Australia, the company has over 150 systems installed worldwide to clients whose work ranges from Radio, TV trailers and commercials, to long form TV and Film projects.

Ron Finkel, partner of Momentum Investment Group based in Melbourne, Australia, commented, "We have a large venture capital fund which is targeted at high tech Australian companies that wish to expand their operations

on a global basis. We spent a lot of time looking at DSP and were very impressed by the dedication and skill of the staff. We also talked with many of their clients and, without exception, they were all very positive



Andrew Wild, new CEO

Internet and Digital Television, DSP represents an exciting investment for us in this rapidly moving market".

DSP founder and head of Prod-

uct development, Joe Narai, was very pleased with the deal.



about DSP's products and service. At a time when television and film production is expanding at a rapid rate, fuelled by the

"DSP is at the stage where we have developed and delivered an exciting product range and have a wide client base - but we lacked the funds to expand our operations and sales efforts internationally. Our first priorities will be to set up a base in Los Angeles and develop new networking technologies to allow us to move into the

Internet age. These funds and Momentum Investment Group's business expertise will allow us to achieve those goals and more".

The firm has also appointed industry veteran Andrew Wild as Chief Executive Officer.

He started his career at the BBC in London. After 5 years at Virgin's (now EMI) Townhouse studios as Chief Technical Engineer, Andrew moved to SSL in 1983 as director of UK and International sales and moved to Los Angeles as VP

West Coast Operations in 1984.

In 1991 he joined Euphonix as VP Sales and Marketing, leaving the company shortly after it went public in 1996.

www.dspmedia.com



3500% increase 'not an error'

Telstra BigPond overcharge Cable Modem user, without recourse

The Telstra Big Pond cable modem at Connections HQ is online non-stop, and checks for emails every minute or so. Our daily usage for the past year averaged 6 megabytes. But in November we were charged for 22,203 megabytes - 740mb per day.

With normal usage averaging \$200 per month, our cable modem bill hit \$7,773.37, with another shock to come in December. That account was for \$2,383, and examination of the usage reports that Telstra supplied (for \$10 each) showed a six week burst of mega-usage.

Suddenly in mid December, our usage mysteriously returned

to normal, and remains so.

It would be extremely hard for anyone to continually download up to 1,500 megabytes a day (more than the capacity of 2 CD's) - especially in the early hours of the morning when most of this traffic was allegedly occurring through our modem.

Telstra spent six weeks investigating, then offered us a \$30 credit with no further dialogue.

We have asked Telstra a series of questions, and told them we would write about this matter in these pages.

They have not responded at presstime.

Feedback: julius@compub.com.au

~ Klaus Engelhard ~

Klaus Engelhard, the Managing Director of Osram Australia Pty Ltd, passed away last month at the ridiculously early age of 59.

Cancer interrupts too many lives.

After 33 years with Osram and its predecessors, Klaus would have accrued a terrific superannuation nest egg - and then he sadly was unable to enjoy it.

Klaus is survived by his wife Elaine, and 3 daughters.



Crown sells to Harman

Leading amplifier manufacturer Crown International, Inc. has reached agreement in principle with Harman International Industries, Inc. for the sale of substantially all of Crown's assets. Harman plans to continue the operations of Crown as an independent business unit under the direction of its current management team at its existing locations in Elkhart with the existing workforce.

"The opportunity to join forces with Harman is an extraordinary one," Richard A. Newberry, Crown CEO told Connections. "The synergies available to us as a combined company are significant."

Crown employs approximately 700 people in Elkhart, Indiana. Annual sales are approximately US\$70 million. The proposed purchase is expected to close as you read this.

Harman own JBL, Soundcraft, DOD, DigiTech, Lexicon and a host of other audio manufacturers. They had sought for some time to add a major amplifier brand to their collection.

1st 2000 audio show reveals little

By John Grimshaw

The Winter NAMM trade show held last month in LA was the first time this decade that all of the pro-audio manufacturers have been together in one place.

Of the new products that were presented at NAMM, there were some notable advances but no really new technological developments.

Try these.....

□ **HDR kills MDM:** Mackie and Tascam debut the \$10k 24 track recorder. Goodbye Ada!

□ **Cheaper desks:** Everyone has a low(er) cost digital mixer, and Sony have downsized the Oxford into a 40 grand marvel!

□ **But no digital wireless:** At least, not the compressed multichannel device we need to get multichannels on one radio mic frequency!

□ **And no revolutions!** Loudspeakers still need cones

and magnets. Drrr!

The massive floor space of the entire west room was filled to capacity with all of the well-known international brands (and a few unknowns that are very likely to stay that way).

Colour, movement, lots of people and very ordinary coffee was the order of the day for the punters, as they compared the various products they were interested in.

One good thing about a pro-audio exhibition: you'll be guaranteed that you will be able to hear the presentations!



Fostex's sexy VM88 mixer



MACKIE SIGNS AGREEMENT TO BUY ALL EAW SHARES

Mackie Designs Inc. and Eastern Acoustic Works Inc. (EAW) have announced that they have signed a non-binding letter of intent by which Mackie will purchase all shares of EAW.

Both sides point out that the arrangement will prove highly beneficial to each entity, while at the same time, both companies will continue to focus their primary energies on their respective core markets.

"I can't stress enough that this move is a win-win for both sides. There will be a cross-pollination of our best technologies, and at the same time we both remain devoted to serving our primary markets," states EAW President Kenneth Berger, pictured above right with Greg Mackie.

It is stated that the majority of each company's operations will remain separate, including product distribution.



'LOTS' new showroom

LOTS OF WATTS HAVE OPENED WHAT MAY BE Sydney's most impressive Professional Equipment Outlet at their Rydalmere complex.

The firm seem to grow an extra building each time we visit, and have now purchased another premises - their third - down the street which handles fabrications and repairs.

Pro Audio and Lighting sales are now in a large and air conditioned space in a former tyre warehouse. Considerable money and brain power has been spent on renovations - the result is a purpose designed space where equipment can be appraised and demonstrated. The hire pickup counter has moved around to the new space, leaving the existing hire warehouse clear for semi movements.

Our picture shows happy/tired LOTS management in the showroom on opening night.

**Visit: 1 Mary Parade, Rydalmere, NSW.
Call: +51 2 9638-0302.**

• L>R: CEO Greg Kean, Production Manager Phil Lewis, Administration Manager Merilyn Croft, and Installations Manager Carey Leghorn.

Connections

Connections Publishing Pty Ltd. (ACN 058443182). A private Australian company, est 1992.

All Mail to:

P.O. Box 439, Epping, NSW 2121 Australia
(deliveries ONLY to 16 Willoughby street)

Phone: +61 2 9876-3530

Fax: +61 2 9876-5715

E-Mail: mail@conpub.com.au

Large files: images@conpub.com.au

Web site: www.conpub.com.au

ADVERTISING: Deadline 15th of each month

Call 1-800-635-514 or +61 2 9876-3530

Director: Caroline Fitzmaurice-Grafton caroline@conpub.com.au

EDITORIAL: Deadline 15th of each month

Publisher & Editor: Julius Grafton

Email: julius@conpub.com.au

Assistant Editors

Catriona Forcer Email: catriona@conpub.com.au

John Grimshaw Email: john@conpub.com.au

Profile journalist: Madeleine Murray

Editorial Alliance: Total Production Magazine (UK)

Regular Contributors:

ADELAIDE: John Matheson **BRISBANE:** Sid Kidman

HOBART: Andy Ciddor **MELBOURNE:** Mandy Jones, Duncan Fry

EUROPE: Zenon Schoepe, Mark Cunningham,
Jacqueline Molloy (London)

USA: Buck Freeman (Detroit), Gary Kayye (NC)

SINGAPORE: Nazir Keshvani **HONG KONG:** Sandy Goh

CREDITS:

Production Manager, Art, Layout: Sharon Miceli sharon@conpub.com.au

Business Development, Marketing: Nicole Morris nic@conpub.com.au

Money: Jenny Royal **Admin, Astronaut:** Sarah Grafton-Ford

Web: Andy Ciddor **Printing:** Superfine, Syd. (4th year) *Ta Gaz!*

Reprographics: Omicron, Sydney (7th year) *Call Ari for film!*

Platform: G3 Mac 400Mhz words very fast (after problems fixed)

Newsagents Distribution: NDD, Sydney. (8th year)

DEADLINES:

Monthly except January, deadline 15th of the month prior.

SUBSCRIPTIONS:

Free call: 1-800 635-514 or fax +61-2-9876-5715 from O/S

AUST: \$48, (12 months) or \$79

(2 years). NZ: A\$80, Asia A\$80, USA A\$115, Europe/UK A\$125.

Pay half price for this magazine

(Aust. only) Buy 5 or more copies to one address each month - for resale or for staff or for customers. Pay only \$2.50 each invoiced quarterly. Call Nicole 1-800-635-514

Legal: All contents © Connections Publishing Pty Ltd, 1999. Nothing herein to be reproduced in any way or transmitted by any means without the express written consent of the Publisher. No Warranty is extended in respect to any information herein. Opinions expressed in Connections are not necessarily those of the Publisher. Materials herein reproduced in good faith. Corrections made wherever material errors occur. It is a condition of purchase that the Publisher does not assume liability or responsibility for loss or damage that may result from any inaccuracy or omission in this publication. Opinions expressed herein are not necessarily the publishers.

100% produced in Australia, air expressed to the entire South East Asian region.

WRITE FOR CONNECTIONS! We WELCOME well written articles and stories for consideration. Send hard copy, preferably WITH a PC or Mac word processing RTF file and NORMAL file together. RTF means Rich Text File, also known as 'Interchange format'. Most word processors will SAVE a file (in the 'Save To...' field) as an RTF file. Colour Photograph prints preferred. Have them printed at 5" x 7" or larger if possible. Digital images- you CAN email us a high resolution 300dpi JPEG image as an attached file, but not a TIFF image. It takes too long to download. Send stamped self addressed envelope if return desired. No responsibility for loss accepted. Call the editor if info required.

ETHICS: We operate under the journalists code of ethics, as detailed by the Australian Media Entertainment and Arts Alliance. Respect for truth and the public's right to information are over-riding principles for all at this publication. In pursuance of this principle we have always committed ourselves to these ethical and professional standards:

1. We shall report and interpret the news with scrupulous honesty by striving to disclose all essential facts and by not suppressing relevant, available facts or by distorting by wrong or improper emphasis;
2. We shall not place unnecessary emphasis on gender, race, sexual preference, religious belief, marital status or physical or mental disability;
3. In all circumstances we shall respect all confidences received in the course of their calling;
4. We shall not allow personal interests to influence us in our professional duties;
5. We shall not allow our professional duties to be influenced by any consideration, gift or advantage offered and, where appropriate, shall disclose any such offer;
6. We shall not allow advertising or commercial considerations to influence us in our professional duties;
7. We shall use fair and honest means to obtain news and documents;
8. We shall identify ourselves before obtaining any interview for publication;
9. We shall respect private grief and personal privacy and shall resist the compulsion to intrude;
10. We shall do our utmost to correct any published information found to be harmfully inaccurate.

- CLARIFICATION -

RCF ART 300A REVIEW, CONNECTIONS FEBRUARY

Connections regrets the inclusion of an ambiguous statement at the conclusion to this part of the comparison article last month. It was our intention to show that the price difference between the RCF product and the Mackie product wasn't an issue. The effect of the sentence may perhaps give rise to the suggestion that one or the other product is more saleable. This is regretted and unintended.

We have chosen to re-run the review segment in full (below) so you can see what this clarification is all about. *Disregard the Conclusion.*

Completing our lineup, the RCF ART 300A comes from the same plant where the speaker part of the Mackie is made. Mackie now own RCF in Italy, but that's where the similarity ends - because the RCF and the Mackie product are completely different, and even have their own distributors. The ART 300A has no front LED, but the back panel is quite comprehensive, with unique setting switches for 'music', or 'voice' - and mic/line. We elected to test it with the switches out.

What they said:

Al: To me it sounded like a passive box, and that's no criticism - there is no distinguishing crossover effect. It's pleasant, it feels like value for money. Worth buying!

John: Orchestral basses not prominent, bass chords less relevant, top of string bass lumpy. I'd have trouble picking 4 (dB Technologies) and this on a dark night.

Adam T: Bass is reasonably tight, low mids well controlled, good definition - not harsh, not offensive.

Tim: No real lows, what there is quite defined.

David: Reasonable detail, it'd be between this and 8 (Mackie) as the best 'all rounder'.

Glenn: Fairly pleasant, low mid thickness that is evident on some parts of voice, flute OK, doesn't have box forwardness and lack of control. Low freq's OK, but perhaps a bit big. Sounds most balanced with pink noise.

Adam I: OK box, high frequency detail a little lacking, seems to be powered nicely.

Conclusion:

Priced at \$2,495, this box would appear to do battle with its Mackie cousin for the hearts and minds of sound people everywhere. The price difference is probably equalised in a volatile marketplace, the only reason you might pay a little more for the RCF is if Mackie are out of stock of their box!



- CORRECTION -

Queenscliffe Music Festival

Queenscliffe is NOT a small town in Queensland, contrary to what the lead line in our article last month states. We can confirm that it is, in fact, located in coastal Victoria. *We are goose-people!*

Adam Iuston



Adam Iuston (left) is - **Adam Iuston**. Accept no substitute! We've managed to mangle his name *two months running*, first in an article he wrote about The Hobbit (Dec-Jan), and then when we did the fabulous speaker comparison last month. *Bad editing.*

Apologies to Adam.

MIDAS HERITAGE 3000

Oops! In the mixing console 'over \$10,000' category, the Midas Heritage 3000 is listed in the ENTECH Awards Book as selling at \$350,000 - whereas the actual price is \$175,000. Connections apologise for the error.

WINNER:

Australian Audio Supplies free trip to ENTECH competition is drawn by Connections' Sarah Ford and AAS's marketing guru, Tony Waine. The winner is **John Power**, from Power Audio Visual in Melbourne.



MAJOR TRADE EVENTS

- ENTECH 2000, March 5th - 7th, 2000. Sydney Exhibition Complex at the Olympics, Homebush Bay. Fax + 61 2 9876-5715. web: www.conpub.com.au
- MusikMesse, March 15-19th 2000, Frankfurt. www.messefrankfurt.com
- SIB, Mar 26 - 29th, 2000. Rimini, Italy. Ph +39 541 71 711. www.fierarimini.it
- NAB, April 8-13th, 2000, Vegas, USA. www.nab.com
- NSCA, April 27 - May 1, 2000. Las Vegas. Ph +1 904 273-2760 www.nasca.org
- PLASA Shanghai, June 7-9. +44 171 370-8231. www.lghtandsound-shanghai.com
- InfoComm International, June 15-17. Anaheim, LA. www.icia.org
- Sounc 2000, June 17 - 19. Auckland. +64 9 373-2572.
- WORLD LIGHTING FAIR, June 22-24. Tokyo. www.wlf.co.jp
- AES 109th Convention, Sept. 22 - 25. L.A. www.aes.org
- SMPTE 2001, July 10-13. Sydney. Ph + 61 2 9939-4445. www.smpte.org

Births

□ Last month **Isabelle Claire McCubbery** finally arrived - a WEEK late - weighing 8lbs, 12ozs (3.97kgs) and seemingly in perfect health. To Marie-Claire and John McCubbery (Music Link).

□ Marshall and Elia (Damien Gerard Studios) welcome their new baby boy- **Miguel Alexander Cullen-Green**.

□ Sydney born, LA based sound guru Bruce Jackson and wife Terri have had a baby girl, **Brianna Sidney Jackson**.

People Moves

□ Connections stringer (and part of the Ciddor lighting dynasty) **Andy Ciddor** has relocated from Perth to Hobart - 'for romantic reasons that are none of your business'. His new contact details are +61 3 6229-1662, email: acidor@kilowatt.com.au

□ **Brad Wright** has left AVSOUND Productions and is now freelance. Contact +61 2 9230-2588, brad@dot.net.au

□ **Lindsay Nelson** has left the Sydney Convention and Exhibition Centre, Darling Harbour, for New Zealand. Contact +64 3 351-5414.

Moves

□ **Multi-Image Lighting** are now at: Suite 3, Olympic Circuit, SOUTHPORT QLD 4215. Phone: +61 7 5528 1253. Fax: +61 7 5528 1256.

□ **Paradise Music Factory** have moved to: Factory 1, Ern Harley Drive, BURLEIGH HEADS QLD 4220. Phone and fax numbers remain the same (+61 7 5575 1990 and fax +61 7 5575 2740).

□ **A Brighter Image** have also shifted, to Unit 6, 16 Ada Ave, Brookvale, NSW 2100. Call +61 2 9938-6866, fax +61 2 9938-6899.

□ **Active Audio** are now at: 66 Abbotsford Rd, BOWEN HILLS, Qld 4006. Call +61 7 3257-7367, fax +61 7 3257-7368.

Venue

□ The **Brolga Riverside Theatre and Convention Centre** opens in Maryborough QLD in July. Contact Chris Olin (Tech Services) on +61 7 4123-8842.

Dealers wanted

UK based company, **Navigator Systems Ltd.** will be at ENTECH demonstrating their best selling rental management software, HireTrack Eclipse.

While in Australia, one of the company directors, David Rose will be investigating the possibility of finding suitable dealers to sell the product in Australia, New Zealand and South-East Asia.

For more information visit website: www.navigator.co.uk

NYE with Trip

Left without a gig after Michael Jackson cancelled his NYE show in Sydney, production guru Trip Khalaf spent new years eve on a large estancia way up river in Paraguay.

"I have a case of good champagne, enough drugs to keep me and the entire village awake and snarling for a week, a big bottle of Viagra, and these two gorgeous Lithuanian hookers I met last year" he wrote in Total Production magazine. Trip Around The World is a CLEARLY a column-with-a-difference!

Khalaf also laments the state of the American music industry thus: "Gangsta Rap has been replaced with this strange EuroTechnoWhiteGuysWhoCan'tFindOneWithADrumLoopDanceStuff heartthrob heaven, boy meets girl stuff. Why can't we make things a bit more interesting and arm these kids? Have them fight it out with large calibre hanc guns and nerve gas..."

Columnists are a tame bunch by comparison with Trip Khalaf!

Alesis MasterLink ML-9600 Now Shipping



MasterLink ML-9600 - the new mixdown and mastering unit from Alesis - is now shipping to dealers around the globe.

MasterLink integrates hard disk recording, digital signal processing, and compact disc creation/playback in a stand-alone system at an affordable price.

MasterLink's high-resolution audio capabilities and built-in editing provide a distinct advantage over less advanced mixdown tools such as DAT, cassette, and standard CD recorders.

It allows studios, musicians and mastering facilities to store, deliver and play stereo 24-bit, 96kHz audio as well as conventional 16-bit, 44.1kHz Red Book CDs on standard recordable compact discs.

"Now that MasterLink is available, Alesis is the only manufacturer to answer the demand for a complete and affordable mastering solution by consolidating 2-track hard disk recording, digital signal processing, and high-resolution CD creation

into one comprehensive unit," says Don Hannah, of Alesis.

"MasterLink will be the key component in any studio that wants to maintain high-resolution audio through the 2-track mixdown process."

Each MasterLink unit will ship with a blank BASF CD-R Master provided by EMTEC Pro Media. MasterLink features a 4.3 GB internal hard drive with editing, digital signal processing and mastering functions, a 4X write speed CD-R drive, and 24-bit, 96kHz A/D and D/A converters.



EV N/DYM UHF WIRELESS MIC

EV's new N/DYM Series UHF Wireless Microphone System, breaks new ground by offering frequency agility features found on more expensive wireless microphone systems. *ClearScan* technology allows the systems to operate on one of 10 user-selected frequencies, and automates system setup by finding the clearest operating channel in any RF environment.

Operation in the UHF frequency band is further enhanced by the Secure-Phase diversity system for clear and drop-out free audio. In addition, the receiver has an adjustable squelch level while the belt-pack and handheld transmitters include adjustable Tx gain controls.

- From Au\$1099
- Call +61 2 96483455 or visit the Web: www.electrovoice.com.

DENON LAUNCHES FLAGSHIP DN-2600F DUAL CD PLAYER FOR DJs

Denon announces the launch of its top-of-the-line dual CD player for the professional DJ market. Offering many of the most popular features found on Denon's DN-2500F and DN-2000F Mark 3 dual CD players, the DN-2600F is also equipped with what they call numerous revolutionary features.

The DN-2600F incorporates two Hot Starts per drive - perfect for instantaneously changing a track or Cue point at the touch of a button. The same Hot Start buttons can also be used to control the machine's new 'Stutter' mode, which plays momentary audio as the buttons are pressed down and then returns to the original point when they are released.

An exciting new 'Effector' mode enables DJs to bring a whole new level of expression to their performances by offering fully customisable frequency filter, reverb and flanger effects. The latter two of these effects may be synced to the music's beats per minute count via the Tap/BPM button, producing reverb decays and flange sweeps that coordinate perfectly with the tempo of the playback material.

A sample of up to 16 seconds may be written with the DN-2600F and played back at any time, even when the source CD has been removed. This sample can be played or looped in either forward or reverse direction.



GEAR TO MOVE?

IF YOU'VE GOT GEAR TO MOVE,
CALL STAGE & SCREEN ON (02) 9383-4544

STAGE & SCREEN
TRAVEL & FREIGHT SERVICES PTY LTD



SHURE UNVEILS PSM 400 PERSONAL MONITOR SYSTEMS

Shure have shown its PSM 400 Personal Monitor System and the P4M Personal Monitor Mixer at NAMM 2000. Shure's PSM 400 and P4M are two ground-breaking and affordable products that make it possible for working musicians to gain control of what they hear on stage by creating personal, in-ear monitor mixes.

The PSM 400 provides an alternative to traditional floor wedge monitoring and shares the hallmarks of Shure's family of high quality, professional PSM systems used by touring artists worldwide.

The new system, like its predecessors, offers: a personal mix, free of unwanted stage sounds; individual volume and balance controls; a freedom of movement that releases performers from standing in only one spot on stage; and an ease of portability far greater than bulky floor wedge monitors.

When used properly, the system can aid performers in hearing conservation. These many benefits are further enhanced by the P4M mixer, which brings complete control of the in-ear mix right to the stage.

"Personal monitors have been so incredibly successful that you rarely spot a touring performer going onstage without being plugged into earphones," said Steve Johnson, Vice President of Marketing for Shure Incorporated. "As the market leader, we knew it was time to create a more affordable version for the working musician."

The PSM 400 and the P4M Mixer are offered both as personal performance packs and as individual components.

EAW Develops Subwoofer to Accompany KF700 Series

EAW has introduced a new subwoofer designed specifically to work with flown arrays of EAW KF700 Series concert loudspeakers.

Called the SB750, the new subwoofer shares the exact same footprint (trapezoidal cabinet shape) as both the KF750 three-way loudspeaker as well as the KF755 downfill loudspeaker.

Sharing the same flying hardware as these models, the SB750 can be flown quickly with any KF700 array.

The SB750 includes dual 18-inch woofers, housed within an optimally vented and tuned Baltic birch plywood cabinet with EAW's road-tough black polyurethane finish. Total weight of the cabinet is only 200lbs.

Rear panel connectors are dual Neutrik Speakon NL4's.

The SB750 offers a frequency response of 30Hz - 150Hz at +3dB, and 25Hz at -10dB. Axial sensitivity, is 99dB (1W/1m), with sound pressure levels of 138dB peak and 132dB long-term (@ 1m)

• More from www.eaw.com

Panasonic

A ray of bright light

Panasonic's PT-L797PE/P Multimedia LCD Projector outputs a brilliant 2200 ANSI Lumens of bright light - an increase in brightness that greatly improves colour reproduction and means more impact for your presentations. But the PT-L797PE/P is more than just bright. In true Panasonic tradition, it also offers a host of versatile, convenient functions:

- Ultra-Bright 2200 ANSI Lumens
- Brite Optic(TM) Dual Lamp System
- True XGA (1024x768), Max SXGA (1280x1024) Resolution
- Intelligent Image Resizing for VGA/SVGA/SXGA/Mac Displays
- 10-Bit Digital Gamma Correction and 3D Comb Filter
- Lightweight/Durable Cabinet
- Stackable for Double Brightness - up to 4400 ANSI Lumens

For more information call 13 2600

Focus on a Panasonic Multimedia LCD Projector

Tiny Good's Rigging Note

No.2: Rated Equipment

Rated equipment is any item that is tested and guaranteed by a manufacturer, and is marked so it is easily identifiable as to the manufacturer and part or reference number.

Industrial gear such as spansets, steel wire rope slings galvanized shackles etc, all have a rating stamped on them specifying either WLL or SWL and the weight, usually in tons. So if a shackle has SWL 3.2T stamped on it, it has a safe working load of 3.2 Tons. If a spanset has WLL 2T stamped on it, it has a Working Load Limit of 2 tons.

Safe Working Load and Working Load Limit mean the same thing.

If any item has NO MARKINGS at all then it is not a rated item, DO NOT USE IT!

Climbing and yachting gear is a little more complicated. Firstly, most of this type of equipment is not stamped with a SWL or WLL. The manufacturers do one of two things, one it stamp the item with a GBL (Guaranteed Breaking Load) or two, and they stamp the item with a part reference number.

If an item has a manufacturer's name, and a reference number or GBL stamped on it, it can still be considered a rated item. For example a yachting equipment manufacturer called Ronstan marks their items with "Ronstan", and a number beginning with "RF". e.g. "RF 618" is a fairly standard "D" shackle and by looking in the reference book, or ringing Ronstan direct, or any Ronstan outlet you can find out the GBL (which for this example is 3600 Kg.).

Be Careful- yachting and climbing gear is rated in GBL not SWL so before deciding on the item you need, you have to apply the safety factors, as discussed in Notes 1 on SWL (*Connections Dec/Jan*).

For example, if we wanted to suspend a person using a RF 618 Ronstan shackle, our Safe Working Load would be 320 Kg.

KILLER NEWTONS- yes I know I spelt it wrong. A lot of climbing equipment manufacturers stamp their equipment in KN or kilo-Newtons. 100 kg. = 1 KN

This is a simplified explanation.

A kilo Newton is in fact a force which is a calculation of Mass x Acceleration due to gravity, but that's for engineers and tertiary physics students.

So back to the topic. A carabiner stamped 20 KN has a GBL of 2000 Kg. So a safe working load of 200 Kg will carry a person.

Disclaimer

The information contained in this note is the opinion of Tiny Good based on industrial training as a rigger, and job experience. No liability is accepted for use or misuse of this information. This material remains the property of Showtech Australia P/L and may not be reproduced without written consent.



YAMAHA'S 16 track, 24 bit AW4416

Yamaha's new AW4416 records up to 16 tracks of true 24-bit digital audio and includes motorised faders with automation/snapshot capability, advanced sampling, DSP features, and much more.

Scheduled for a June rollout, the AW4416 offers multiple storage options—including an internal hard drive and CD recorder, as well as a SCSI interface for data backup to an external drive.

As a digital mixer, the AW4416 contains full 32-bit DSP capabilities (similar to that of the Yamaha 02R). 44 fully-automated audio inputs (16 of which are from the internal hard drive), 17 motorised faders, four fader and mute groups, eight bus and eight aux sends plus stereo, and stereo cue busses. All 44 inputs—including eight analog and 16 digital inputs via optional interface cards—contain digital attenuators, 4-band full parametric EQ, and direct out assignment.

The rear panel contains eight 24-bit mic/line inputs, two of which are XLR with +48V phantom power and inserts, plus a high impedance input that will accept a guitar or other instrument, directly. Memory areas include scene, channel, EQ, dynamics and effects.

An inclusive 16-track recording system, complete with sampling, editing and mastering capabilities, retains true 24-bit, 48 kHz resolution without compression of any type. Two 32-bit on-board effects (including Yamaha's reverb) may be routed to any bus

or input channel directly, or re-routed during recording to create layered effects.

For the first time, Yamaha engineers from different divisions have collaborated to bring together technology from both Professional Audio and Electronic Music.

This is evident in the internal sampler, which accepts samples from a CD or internally recorded tracks, and allows extensive

editing/looping capabilities. The user can trigger any of these samples from the two banks of eight available pads.

Two rear-mounted card slots allow any or all of the 16 tracks, inputs and assigned busses to be output in digital form for further processing or for transfer to external digital devices. These slots will also support future products from Yamaha and third party developers. A FLASH ROM operating system enables software upgrades to be loaded from CD or the Internet.

The AW4416 offers an optional CD-RW drive, which enables users to burn audio CDs (after mastering on the hard drive), load and/or backup data. This drive is installed in a front-mounted port for easy accessibility.

Aimed at project studios, musicians and song writers, as well as those involved in pre-production and editing, the AW4416 is expected to sell from about A\$5,500 when it arrives in Winter.

• See it at ENTECH, or visit www.yamaha.com/proaudio

SEE IT. HEAR IT. BELIEVE IT.

SEE US AT ENTECH
STAND U3



BUY IT...

...from the company that's been creating new technologies in professional audio since 1927.

Check out our latest advances in professional audio:

- **N/DYM® VOB™** (Vocal Optimized Bass) microphones virtually eliminate distortion and "muddiness" in the lower vocal frequencies.
- **N/DYM® ClearScan™** wireless systems offer a revolutionary automatic channel selection feature.
- **Eliminator®** and **Force®** sound systems boast matching speakers and power amps that offer incredible value.
- **SX-Series™** speakers 3 new models including the **SX-80** designed to meet the needs of musicians and contractors seeking a compact, high performance system.

Whatever the application – clubs, churches, studios, or stadiums, EV sets the standard for innovation, performance, versatility, and value. Believe it TODAY by putting EV to work for you.

EV EVERYWHERE™

www.eviaudio.com.au

EV AUDIO
A Division of Tricon Communications Inc.

Head Office: Tel 61 2 9648 3455
Victorian Office: Tel 61 3 9810 4511

ALLEN & HEATH ML5000 CONSOLE

Allen & Heath's new flagship live console has arrived. The ML5000 is a VCA-equipped 16 aux, 8 audio group mixer with 8 mute groups, matrix and enhanced LCR and IEM facilities.

Furthering Allen & Heath's 'dual functionality' concept, the ML5000 has a uniquely flexible group/aux structure allowing engineers to quickly configure

the mixer for FOH, monitor and combined roles. In FOH mode, there are 8 audio groups, 8 VCA groups, 16 auxes, 8-way matrix and left, right and centre outputs. In dedicated monitor mode, the console offers 16 aux mixes, left and right outputs, all with faders, inserts, talkback and metering, while the centre output becomes an engineer's wedge.

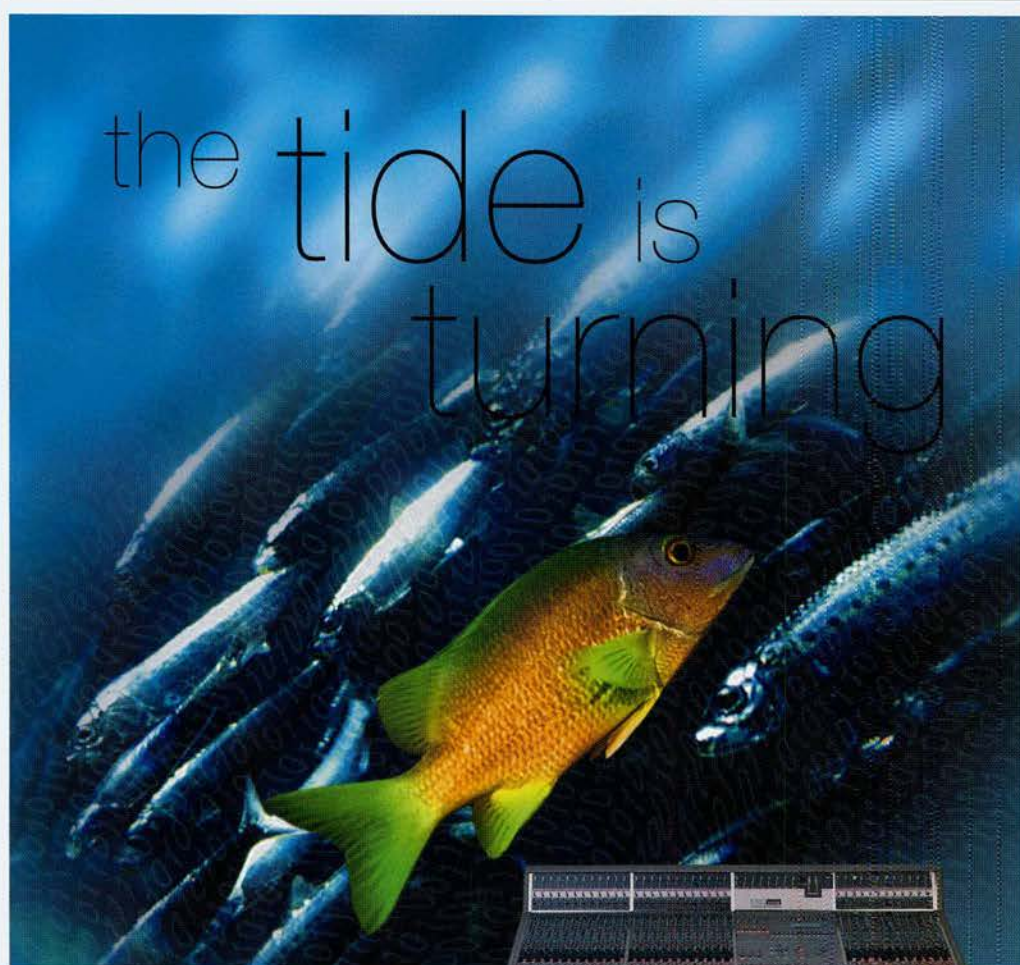

In an ocean of digital consoles the latest competitor is analogue.

The ASP8024 boasts exceptional sonic performance, with an arsenal of features normally found on far more costly consoles.

Just what you would expect from Audient Analogue Signal Processing technology.

ASP 8024

HIGH RESOLUTION MIXING CONSOLE

audient

Corporate Audio Services A/CN 088 463 629
188 Plenty Road Preston Victoria 3072
Ph. 03 9474 1067 Fax. 03 9474 1070
URL www.corporateaudio.com.au
Email rowlands@corporateaudio.com.au

Digi goes Rocket

Digidesign and Rocket Network have announced plans for a strategic alliance, to work together to develop technologies and services that enable Pro Tools users to collaborate using Digi internet studios.

Digidesign have also launched Windows 98 support with Pro Tools 5.0.1, the first upgrade to its Pro Tools 5 software. Among the key updates to Pro Tools 5.0.1 is the support of Windows 98 by the Pro Tools-LE powered systems Digi 001 and Digi Toolbox XP.

Digi also announces the release of Dolby Surround Tools 2.0. Developed in response to the growing demand for surround sound with everything from TV shows to video games, Dolby Surround Tools TDM plug-ins for Digidesign Pro Tools workstations are now available. These plug-ins provide Pro Tools users with Dolby Surround encoding and Dolby Pro Logic decoding without the need for separate hardware, making it more efficient for them to create software for systems equipped for Dolby Surround playback.

CM Automation's MotorMix, the low-cost control surface alternative for Pro Tools and other digital audio systems, MotorMix is a compact mixing and control surface for Digidesign's new home studio - Digi 001.

Finally, Digidesign reports more than 1 350 ProControl units have been shipped to date. ProControl provides high-quality hands-on control for mixing, editing, and processing.

WAVEFRONT LONGTHROW™ OUT IN FRONT AT ANY DISTANCE

Awesome power from compact enclosures, with no need for delays. Flexible configuration, includes compatibility with award-winning W8C.

True longthrow reinforced sound from innovative, high efficiency horn loading and vertical line array format pioneered by Martin Audio.

Intelligible sound proven in performance at prestigious outdoor festivals.

W8CM dedicated longthrow low-mid enclosure with two vertically aligned horns powered by 12" drive units.

Column of W8CM low-mids throws 120Hz-750Hz information beyond 200m for exceptional clarity in the farthest stadium seats.

Robust enclosures designed for ease of handling, set up, stacking and secure flying.

Inventory of Longthrow and Wavefront W8C systems equips touring sound companies with the superior muscle to tackle any scale of venue.

Vertically coupled elements deliver exceptional efficiency by narrowing vertical coverage and increasing main axis output.

W8CT dedicated longthrow high-mid / HF enclosure overcomes air absorption over distance outdoors.

Amazing HF energy from 6 x 1" ext HF drivers optimised for 3.5kHz upwards - outperforming all competitors.

Maximum throw from 3 x high-mids in line array covering 750Hz-3.5kHz. Sophisticated design features 6.5" driver loaded by toroidal phase plug and constant coverage horn moulding.

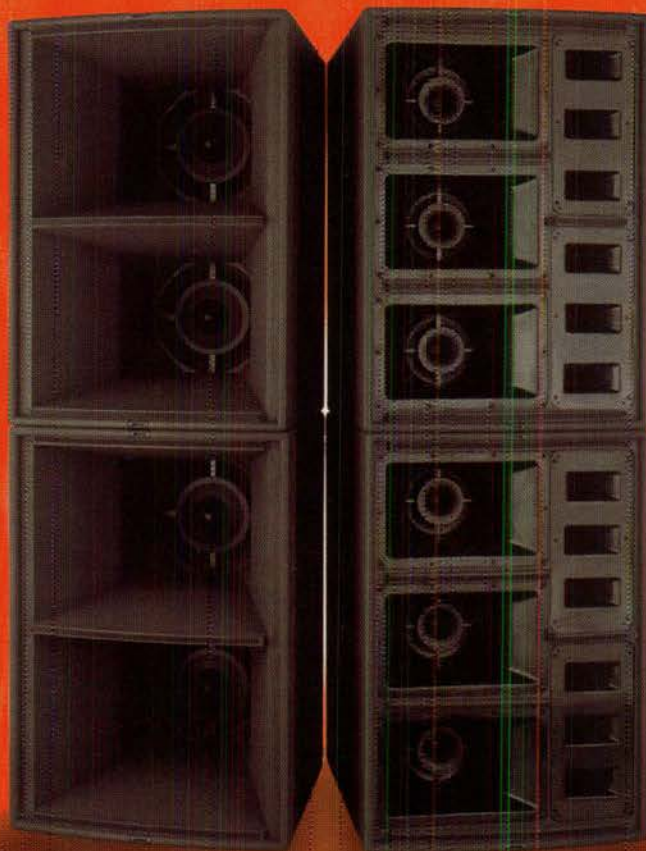

HF ATTENUATION OVER DISTANCE

Air Absorption vs Frequency
20°C and 50% relative humidity

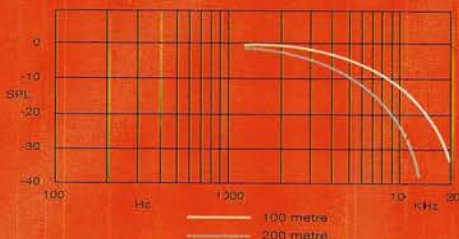

Wavefront
Longthrow™



TECHNICAL AUDIO GROUP

558 Darling Street, Balmain NSW 2041
Ph: (02) 9810 5300 Fax: (02) 9810 5355
Web: www.tag.au.com E-mail: info@tag.au.com

Sony's DMX-R100

'Son of Oxford' a hot new 40 grand Digital Audio Mixer is previewed at NAMM. John Grimshaw reports....

Sony have developed a full featured little brother to the Sony Oxford OXF-R3 that fills a wide market gap between smaller consoles and the large production consoles used for digital mixing.

The desk is capable of controlling up to 48 channels of audio at 44.1 or 48kHz, or 24 channels of 88.2/96kHz audio. It has automated faders, touch screen display control, transport control, and full 5.1 surround capability and an intuitive channel system. The whole product seems to be designed to take the difficulty out of controlling the technology. Controls

The console's features and operation are extremely easy to understand. One of these features it takes from its big brother is the 100mm faders. These automated faders have a 10bit (1024 step) resolution rather than the 8bit (256 step) typical to most of the smaller consoles.

This gives each step of the fade a 0.1dB resolution – enough for very smooth and exact control. Each fader is also a touch sensitive control. When the user is listening to the post mix and makes an adjustment to the levels, for as long as the user has his or her finger on the control, that new level is being instantly updated onto the mix without having to stop the mix enter or leave a control recording mode.

When the finger is removed from the control, the fader fades back to the levels previously recorded over a preset time. Unfortunately, Sony is yet to develop a feature that allows for a modified level to be applied to the remainder of the entire mix. So either you have to listen to the entire mix with your finger on that control (a bit of a cumbersome option if you are post-mixing a movie) or perhaps a fake finger from a joke shop and a bit of gaff might help?



When I posed this question to one of the Sony representatives at NAMM, they indicated that this problem may be addressed in future software updates.

The picture at right also displays the controls for

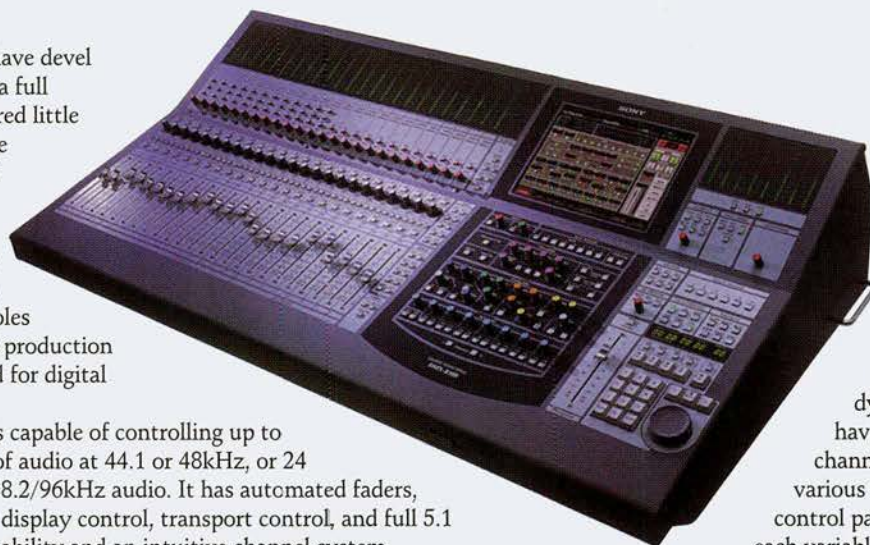

any channel simply requires the pushing of one button, once. By pressing the "Access" button on the channel interface, instantly all of the settings for that channel are transferred to the control panel and can be adjusted.

These adjustments are reflected on the onscreen display, which gives the user an accurate representation of the effect being placed on the channel. The speed and simplicity of this system is obvious, and it will probably not be long until this type of implementation is picked up by other vendors. This is because the user does not have to stop and think "Now what are my assignable pots doing at the moment" when all he or she wants to do is a minor change to the EQ.

The 5.1 surround implementation on this mixer is very well designed. Each channel can be "panned" to any location in the room either by directly using the touch screen as in the above picture, or via a mouse control. This panning can also be done in real time as the mix is being played, thus making it very

toggling between the 48 possible inputs, as well as the Master outputs. For each selection, the faders instantly move to their respective positions as set for that particular point in the time code. For the Master outputs, the 24 faders control the eight main MTR outputs, eight aux sends and eight aux returns.

Another very interesting feature is the way each channel's EQ, Aux assignment, bussing and dynamics is controlled. Rather than have three assignable knobs on each channel and these able to page through the various functions, the R100 has a single control panel that has a fixed function pot for each variable control. To access the settings of

each channel simply requires the pushing of one button, once. By pressing the "Access" button on the channel interface, instantly all of the settings for that channel are transferred to the control panel and can be adjusted.

These adjustments are reflected on the onscreen display, which gives the user an accurate representation of the effect being placed on the channel. The speed and simplicity of this system is obvious, and it will probably not be long until this type



Introducing

Digi 001™

at \$1995

Powered by



The complete audio/MIDI hardware and software package from the leader in digital audio.



+



+



=



One Solution. One Company.™

Pro Tools™ LE 5.0 Software

- 24 Tracks of 24-bit Audio
- MIDI Sequencing
- Fully Automated Digital Mixing
- Powerful Audio & MIDI Editing
- Real-Time AudioSuite™ (RTAS) Processing
- with Free DigiRack™ Plug-In Effects

Single PCI Card

24-bit I/O Box

- 8 Channels Analog I/O
- 2 Channels Mic Pre-Amps
- 2 Channels S/PDIF
- 8 Channels ADAT Optical I/O
- Monitor & Headphone Outputs
- QuickPunch Footswitch
- MIDI I/O

Available Now



* Windows availability expected early 2000.

For more information, contact us
at 03 5428 7780
or www.digi001.com

Real-Time AudioSuite (RTAS) Plug-Ins available from Digidesign and our Third Party Development Partners

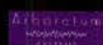

Upgradeable to our award-winning Pro Tools™ 24 family of products



digidesign®

A division of **Avid**

©8/99. Digi 001, Dig-Rack, Real-Time AudioSuite, Pro Tools, and Pro Tools LE are trademarks or registered trademarks of Avid Technology, Inc. or its subsidiaries or divisions. All trademarks are the property of their respective holders. All features and specifications subject to change without notice.



easy for sound to be easily placed in and moved around the room. Coupled with the six channel control room outputs for direct, real time monitoring of the result, this desk is specifically designed to make surround mixing fast and intuitive.

Inputs and Outputs (I/O)

The first 12 of the 24 analogue inputs are individually switchable between an "A" or "B" source. The "A" source inputs are fed by 12 XLRs at microphone level, each with selectable phantom power.

The "B" source inputs are line level TRS jacks. These first 12 channels also have "Insert" jacks for external signal processing. The remaining 12 channel inputs are line level "Coaxial XLR/ 1/4 TRS" connectors, and there are eight aux returns (4 analogue, 4 digital). The onboard outputs include a stereo program out, six control room monitor outs, eight aux sends and a stereo studio monitor out.



All of the analogue I/O's use 24bit, 128x oversampling converters. There is also a range of optional 24 channel I/O cards for tape returns that are available to suit the requirements of the user. These include analogue, AES/EBU, ADAT, and T/DIF.

There are a few transport control interface options available on the desk as standard. These include MIDI MTC time code, Word Sync, SMTPE/EBU Time Code and Sony 9pin remote.

Other connections include PS/2 Mouse and Keyboard sockets, foot switch, PC Port, USB and a serial 9pin connector.

There is also a 15pin video connector which replicates the SVGA touch-screen (so you too can do what seems to be the norm at trade shows, and plug in that spare plasma screen that always seems to be lying around).

Specifications

Perhaps one of the most disarming aspects of this desk is its size. For all of its features, the desk itself is not all that different in size to a standard 24 channel desk, its footprint being 1135mm x 690mm.

However, at 55kgs, I would not suggest you try to lug one around too often.

There are no internal fans, so the desk itself is purely silent. The R100 is expected to be available between March and May this year, and the price will be in the vicinity of US \$20,000, or about 40 grand in Australia.

Lots of BARGAINS

Things are changing at Lots Of Watts.

We have now opened our new showroom and to celebrate we are having a 12 HOUR SALE on TUESDAY MARCH 14th from 9:00am to 9:00pm.

Our showroom now features

- LARGER range of stock
- HANDS ON displays
- AIR conditioning
- MORE parking
- NEW ADDRESS: 2 Bridge Street Rydalmere - directly behind our old building in Mary Parade

2 Bridge Street, Rydalmere NSW 2116
 Phone +61 2 9638-0302, fax 9638-0331
 sales@lotsofwatts.com.au
 hire@lotsofwatts.com.au
 www.lotsofwatts.citysearch.com.au

The company everyone else uses

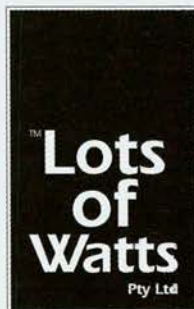

No longer do you have to lose the fight to difficult acoustical environments...

Installed in the Manhattan City Centre Theatre, New York

Now There's a Choice!

Don't settle for speakers that are large and unsightly to get the directional control you require. Apogee's new family of Linear Array Loudspeakers deliver the sound where you need it: to the audience. ALA speakers let you focus the sonic energy with astounding accuracy and precision, keeping it off walls, ceilings and other surfaces that cause destructive reflections.

Off-axis rejection is equally impressive, allowing sensitive podium and lavalier mics to achieve levels that were previously unheard of. The result is greater articulation, clarity and intelligibility than ever before.

A wide range of vertical dispersion patterns can be created quickly and easily, thanks to our flexible rigging system. And only Apogee provides a choice of models to meet any requirement. The ALA-3 (pictured above) comprises dual 10" cone drivers and dual 1" throat horns, and is ideal for theatres, ballrooms, houses of worship and similar venues.

The ALA-5 is equipped with dual 15" cones and higher power HF drivers, for larger venues ranging from theatres to sports arenas. And finally there's the ALA-9, a three way, tri-amped system suitable for the biggest concert venues, indoors or out. Apogee Linear Array Loudspeakers give you the means to win the war against problem venues. Just think of what they'll do in the easy ones!

Call, fax or write today to learn more about this advanced technology or to arrange for a demonstration.



ALA-3

Suited for theatres, hotel ballrooms, houses of worship and more.



ALA-5

Ideal for concerts, musical theatre, industrials, theme-parks, and performing arts centres.

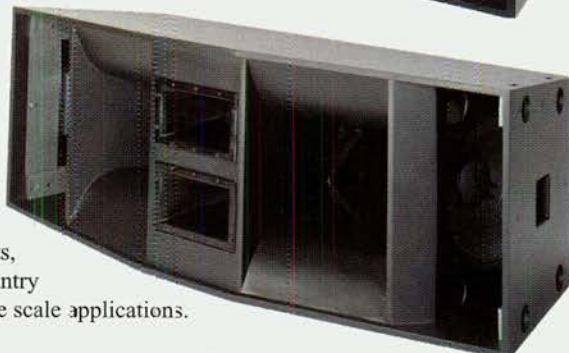

ALA-9

Designed for rock concerts, sporting events, outdoor pageantry and other large scale applications.



Distributed in Australia and New Zealand by:
CMI Professional Products Group.
Phone: 61 3 9315 2244 Fax: 61 3 9315 2115

APOGEE
SOUND INC.



Long Audio Days at High Five

Nine crew make fast and effective TV

By Julius Grafton

Audio director Steven Korres is on Take 5, run 3, when the floor manager exhorts the audience to say: "Thank you Steve!". One hundred five year olds have no idea what an audio director is, nor do they care. They are there for the wholesome fivesome, who positively ooze charisma and niceness. The fountain of youth is overflowing here.

Nine are making five episodes in two and a half days, the first two days are brutally long ones for the audio crew - starting at 0600 and ending after dinner. The cast rehearse for two days beforehand, then cut the show with live singing and dialogue.

Day three is a little more sedate - Song Of The Week - and today it's 'Animals Inside Me'.

The 'Five cut the vocals at Trackdown first, the audio crew roll the CD on a Tascam CD 601 CD cart, and the 'Five mime while they do all the visual stuff. It's cute as hell, and the audience of especially invited five year olds all sing and make moves too,

having been processed first by a choreographer next door.

There are a lot of takes to be ... taken, and multiple versions of each. The 'Five wear DPA 4065 headset mic's, which are live at the end of the song where they say, 'Hi, I'm - and we're Hi Five!' The audio crew say the DPA's are great, and quite omni directional - which makes them less good with foldback, 'cause they are more prone to feedback.

These, and some effects mic's, are all that need to be captured by the audio team, which comprises Steve and assistant Luke Armstrong. They are in front of Nine's classic SSL SL 6000E console, watching proceedings on monitors since a cyc covers the windows.

From the desk a four channel mix, comprising effects, vocals, music left and music right, goes direct on tieline to Digital Beta. dialogue between 2 or 3 people then straight to a live song with 2

(continued on page 63)

for those about to rock

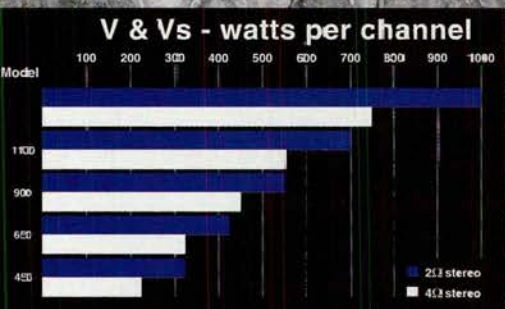

Crest Audio presents the V & VS Series
Amplifiers designed to deliver all your music - always.
Earth-shaking bass and effortless mids & highs come from generous
power reserves. Fail-safe protection & road-tested reliability
keep you in business, night after night, year after year.
All created by the maker of the world's
leading concert sound amplifiers.
About to rock?
Power up at your local
Crest Audio dealer.



EXCLUSIVE AUSTRALIAN DISTRIBUTOR: PRODUCTION AUDIO SERVICES
 6-8 Elizabeth Street, Richmond, VIC 3121 • Ph: (03) 9415 1585 • Fax: (03) 9415 1595
 Web site: www.productionaudio.com.au • Crest Audio Web Site: <http://www.crestaudio.com>



If music be the food of love let's hop in for our chop

By Duncan Fry



I'm a bit of a connoisseur of fast food. So much so that the doctor calls me Saturated Fats, which is a little unfair since I haven't been near a pool hall in years.

I suppose it's a legacy of days and nights on the road, eating on the run in all sorts of places, because when you're out on the road, food is survival. A way of stoking the body's fires to keep going for another 20 hour working day, so it needs to be fast, hot and good.

Usually it's any two of those three!

It's an added bonus if it can be available at a petrol station roadhouse so that the hamburgers, chips, drinks etc. can be surreptitiously added to the band's petrol bill.

"Geez the old truck must be running a bit rough guys - we seemed to have used an extra hundred bucks of juice - look, here are the receipts!"

There is also an unspoken bond between you and the person who sells it to you, and that is - once you've eaten the food, that's the last you expect to see of it. Life being what it is, though, it doesn't always happen that way, which is one reason why the major fast food chains do so well. If you pull into Pigsknuckle, West WoopWoop and there's a choice between getting something from the totally unknown local greasy spoon or Hungry Mac's, then Hungry Mac's wins every time. It might a little bland and predictable, not exciting thought provoking cuisine, but least you'll have someone with deep pockets to sue if your stomach explodes like an outtake from Alien!

I've just come back from doing the NAMM show in Los Angeles, and so have had the opportunity to sample the mother lode of road food, US style.

As everyone who's experienced it will agree, Southern California has a very special smell at sundown. It's the heady aroma of hot lard, gently wafting its way from thousands of fast food palaces to

your olfactory senses. Like the siren's song of the ancient seafarers, the hamburger faithful are inexorably drawn by this irresistible fragrance, night after night, to end up chomping on some giant slab of minced cow and a bushel of fried potatoes.

Considering how much fast food I've sampled over the years, the bad experiences have been few and far between. A steak ordered rare that left me doubled up in agony all night, and put me off rare steak for about five years from a beachside diner in Venice, California; a late afternoon (a bad food time, having usually been kept warm since lunch) burger that had me doing the Tijuana two-step; and that was about it. I should have known my run of luck had to end sometime.

Anyway, I had a couple of days spare after the show, which I'd planned to use cruising around the wrecking yards of Southern California looking for elusive Plymouth parts to get the Roadrunner up and running. I had a lead on a tailshaft, from Tony's Truck Wrecking in El Monte. It's a bit of a drive, and I hadn't eaten since breakfast and it was now 3 o'clock, so as I drove through downtown El Monte I saw a sign for Bobby's Original Burgers.

Never tried one of them, I thought, and drove into the parking lot and walked up to the counter. I ordered a cheeseburger.

"You want the works on that?" the lady drawled.

"What exactly is the works?" I asked.

"It's onionsketchuppepperpicklesmustardextracheesechilliand barbecuesauce," she rattled off at breakneck speed.

"Er... OK," I said, having not really heard properly, "And give me some chilli fries as well." Might as well go for broke, I thought.

"Oh yes, and a Doctor Pepper".

Well, whatever else the meal was, it was certainly good value -

> please turn the page

**Need to buy
or update
your AV
equipment?**

- Maybe you just want to check out what new equipment is available.
- You may just want to sell some old equipment.
- Are you just looking for the right job in the AV industry?

WELCOME TO...

audiovisualshop.com

...THE NEW WAY TO BUY OR SELL YOUR AUDIO VISUAL EQUIPMENT

- We're open 24 hours a day, 7 days a week
- We have a huge product range that keeps getting bigger
- We deliver to your door and offer superior after sales service

and the best news is ...our low prices on

Public Address and Sound Reinforcement Systems - Stage and Effects Lighting
- Conference and AV Equipment - CCTV Systems

Come and visit us @ www.audiovisualshop.com

- You can also contact us - Telephone: (02) 9554-5310 - Facsimile: (02) 9150 6226

YAMAHA MIXERS DID YOU KNOW?

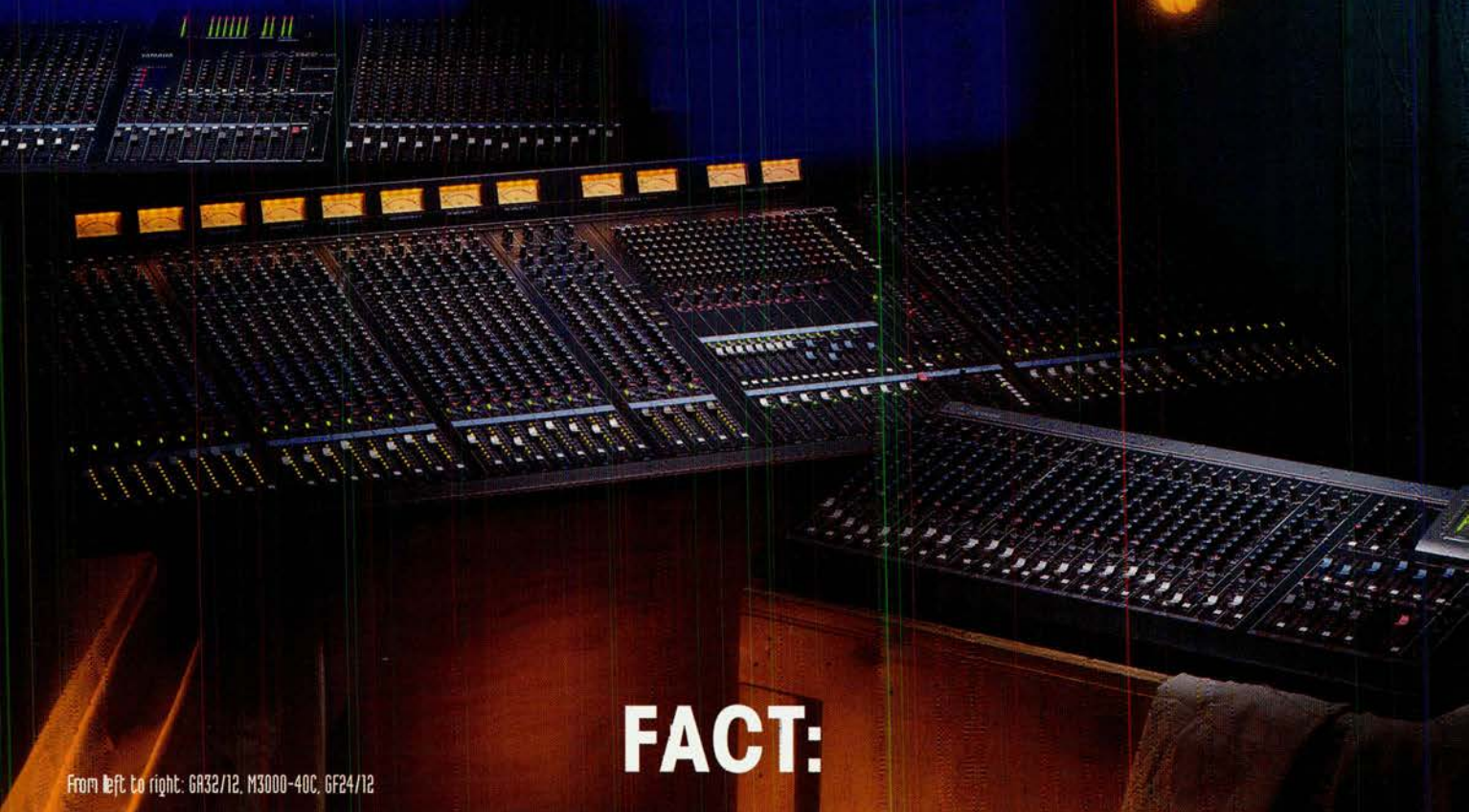

FACT:

From left to right: GR32/12, M3000-40C, GF24/12

Yamaha consoles are specified by more hours than others. And with good reason. Refined and developed over the years, Yamaha has achieved an enviable reputation for dependable quality. From power supplies to potentiometers, every component has been rigorously tested and retested by Yamaha engineers. Their passion verges on obsession. And now, with the introduction of three new consoles Yamaha reliability is reaching brand new audiences. The prices you'll find are hard to believe. The quality you already know about.

M3000 Series - from \$26,995 RRP

- Available in 24 or 40 mono input channel versions, both with an additional 4 stereo channels
- Mono inputs with XLR-type microphone/line connectors • Phantom power individually switchable on all mono inputs • Stereo channels have both "A" inputs (1/4" jacks) and "B" inputs (RCA pin jacks) • Group/Aux Diversity System for a wide range of signal-routing requirements allows the console to be used as FOH or monitor mixer... or both! • Midi Mute Groups with 8 hard assign switches and 128 scene memories with MIDI-control capability • Input channels can be individually assigned to any of 8 VCA groups • 20x8 submix matrix provides eight independent mixes of the signals on the 16 mix busses, the stereo buss, and matrix sub inputs • Outstanding RF noise rejection eliminates unwanted interference and assures a clean clear signal • Insert send/return patch points are included on all mono channels, stereo channels, as well as mix, aux and stereo busses • All mono channels feature switchable high-pass filters, sweepable from 20Hz to 400Hz • Mono channels have a flexible 4-band equalizer, with sweepable frequencies in all 4-bands and switchable bandwidth for the HI MID and LO MID bands • Fixed-frequency 4-band equalization with switchable HI MID and LO MID bandwidth on stereo channels • EQ bypass switches are provided on all channels • Dual (redundant) power supplies may be used with no switching unit required.

GF Series - from \$1895 RRP

- Available in 12, 16 or 24 input channel versions • Mono input channels feature both XLR and TRS type connectors • Phantom power and insert jacks available on all mono inputs • Stereo inputs are switchable between "A" input jacks and "B" input FCA type pin jacks • Three band EQ with switchable midrange on mono inputs plus HFF • 6 Aux Sends: aux 1 and 2 are fixed "pre" and auxes 3/4 and 5/5 are "pre" or "post" selectable • Input channels assignable to any or all of the four busses and/or stereo outputs • Two stereo aux returns with independent return level control feeding the 4 groups, aux 1-4 and stereo busses

GA Series - from \$5295 RRP

- Available in 20 or 28 mono input channels versions • Both consoles have 2 stereo input channels in addition to mono inputs • Mono inputs have both XLR type microphone connectors and balance/unbalanced TRS phone jacks • Phantom power switchable in groups of 4 for all mono inputs • Twelve Mix Busses: ten mix/aux busses plus (dual) stereo busses • GA Diversity features allows the console to be used as a FOH or monitor mixer • Two matrix sub-mixes from the M1 through M4 mix busses and the stereo buss • Four stereo aux returns with independent level controls • Record Out/Tape in feature • Compressive monitoring via control-room monitor and headphone outputs with independent level controls • Peak-reading level meters provide accurate visual monitoring of the signal appearing at the ten mix busses, the stereo buss, and the PFL and AFL busses

For More information contact Yamaha Music Australia

PO Box 268, South Melbourne Vic 3205 Toll Free 1800 805 413 Fax: (3 9693 2332

Web Sites www.yamaha.co.uk

www.yamaha.com/proaudio www.audio-technica.com



ACN C04 259 527

total cost \$4.35, including tax. The steaming trayful appeared in about 30 seconds, and I sat down at an outside table in the sunshine, surrounded by assorted pensioners gummily sucking on cups of chilli. You can always tell if a place is good value if pensioners eat there, I reasoned.

I ploughed my way through as much as I could, but have to confess that even with the help of my 2 litre cup of Dr Pepper, about half the burger and the last few chilli fries were beyond me. Burping happily, I got back into the car ready to haggle with Tony.

About half an hour later, I was driving back down the 605 freeway, tailshaft on board, when all of a sudden I started to feel rather hot and sweaty. The road started to gently wave up and down and spin sideways, and I felt distinctly unpleasant stomach rumblings getting stronger and stronger.

Yikes! I wrenched the wheel and aimed the car into the emergency lane, hit the hazard flashers and leaped out of the car, just in time to revisit Bobby's burger and fries and drink as they hurtled past my tonsils and into the bushes. Talk about Agent Orange - this stuff ripped through the foliage like liquid flamethrower!

The landscape gradually stopped swaying and I leaned back against the car with the feeling that something was definitely better out than in.

It would have been about one minute from the time I stopped to when the Freeway Emergency Service tow truck pulled up in front of me. A free service that patrols the freeways all day and night, helping people who have usually broken down, not thrown up, but it was good to know that someone was out there.

I walked up to the truck cab and opened the passenger door.

"I'm OK," I said to the driver, Jerry, a very helpful guy of probably Mexican descent, but whose skin paled visibly as he caught the full paint-stripping force of my breath!

"I just had a burger at Bobby's", I explained, then to avoid the risk of him losing his lunch in the bushes too, I gave him a sign language explanation of where Bobby's burger had ended up. He laughed. "Bobby's Burgers? Hell, you gotta be crazy to eat those things. I wouldn't eat there if you paid me!"

Now he tells me.

• *When he's not depositing toxic waste by the side of California freeways, Dunk is a director of ARX, and runs dunkworld.com. Have any food stories to share? Email him: dunk@dunkworld.com*

Letters

Speakers

Congratulations on putting the Powered speaker article together, read well. The shipping carton that we shipped the SPL12 was not the usual packing method, they are normally shipped in pairs on a shipping pallets encased in foam and cardboard. The pallet is export standard designed for air freighting or stacking in shipping containers.

**Colin Park, Managing Director
ARX Systems Pty Ltd, Melb.**

Good article, but what about maximum power handling and specifications?

- R. Robb, email.

• *Like we said in the article, we aimed to do something the average buyer couldn't, appraise the actual sound of the boxes. -Ed*

I haven't heard of any of the 'golden eared experts' you quoted in your speaker story. Why not get some of the great sound men from off the road?

- BonesT, email.

• *Sound MEN? What are they?*

I loved some of the descriptions of sound in that story! eg: 'fizzy', 'shouty', etc.

- Monique Ferris, email.

Fry on the internet

While I agree with most of your article, (*Feb*), especially the point about banner ads on site simply leading people away from that site, there are a few significant things that you missed.

All web browsers now have a "turn graphics off" function (usually in the options, or preferences section), which will markedly increase the speed with which web pages download. "Opera", a web browser, even has a button in the main window which toggles the downloading of images.

You mentioned printing white text on a black page, and said you had a blank page pass through the printer. Most version 4 (or higher) browsers have a "force text to print black" option.

To get rid of banner ads, I use "JunkBuster". Works with any browser (or rather, regardless of web browser), and gets around 98% of banner ads.

You mention a local vendor's website, where they admit that a form function has never worked. This is a pet hate of mine, too! That "good enough", or, "she'll be right" attitude of Australians is extremely annoying.

BTW, I thoroughly enjoy your monthly column in Connections!

- Garion Hall, email.

Come see & hear cost effective alternatives



CHIAYO

The Wireless Microphone Company



Listen™



JTS

PRO AKUSTIKA

imp



Come and see us at Entech (stand No. BB9) and we'll show you our complete new range of exciting audio products that continue to offer you the best cost effective alternatives. Collect your free brochure that showcases our extensive range.

N | S | C | A |

National Systems Corporation of Australia Pty Ltd

Ph: (03) 9434 1888

Fax: (03) 9434 1866

Interstate: 1800 441 440

Email: nsca@ozemail.com.au

MediaMatrix®



*The World's Most
Powerful Audio
Tool*

NET Generation

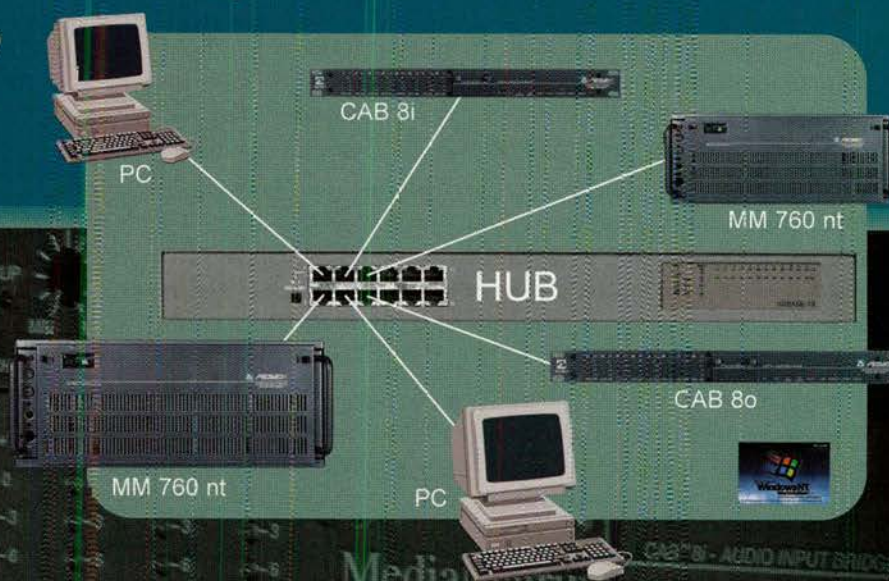

- ▶ *More worldwide installations than any other DSP system*
- ▶ *Leading the industry in the number of audio channels available on a network*
- ▶ *More processing power than any other digital audio system*
- ▶ *Interoperable digital audio via CobraNet™ and AES/EBU*
- ▶ *True routing of audio via Ethernet*
- ▶ *The industry's most extensive digital device library with the ability to create your own devices*
- ▶ *A true, fully programmable system*
- ▶ *The most advanced control facilities:*
 - ▶ *Serial- for connection to AMX, Crestron, Alcorn McBride or any other serial control system*
 - ▶ *TCP/IP- RAMM (Remote Access MediaMatrix) allows multiple users to control one or more MediaMatrix with a "personal" control screen*
 - ▶ *Write your own application programs with Visual Basic or Visual C++ utilizing COM or ActiveX technologies.*
- ▶ *Amplifier control via Peavey AmpWare™*

AUDIO TELEX

COMMUNICATIONS

www.audiotelex.com.au

Need a brochure or further information?
e-mail us at marketing@audiotelex.com.au

NSW: Tel: (02) 9647 1411 Fax: (02) 9648 3698
VIC: Tel: (03) 9890 7477 Fax: (03) 9890 7977
QLD: Tel: (07) 3852 1312 Fax: (07) 3252 1237
WA: Tel: (08) 9228 4222 Fax: (08) 9228 4233
TAS: Tel: (03) 6226 6373 Fax: (03) 6278 1063
SA: Tel: (08) 8352 4444 Fax: (08) 8352 4488
NZ: Tel: (09) 415 9426 Fax: (09) 415 9864



PEAVEY

ARCHITECTURAL ACOUSTICS

VISIT US ON THE WEB <http://aa.peavey.com>

Barbra Streisand show set to challenge poor venue acoustics in Sydney

45 trucks for interstate run, 25 sea containers ship gear including new i4 PA from USA. Julius Grafton reports:

Timeless is priceless, as tickets selling for up to \$1,527 are snapped up for Barbra Streisand's Australian outdoor concerts this month. Just four shows will be staged, two in Sydney and two in Melbourne - and they are the first outdoor shows for the star since the start of her career, not counting a private party in Beverley Hills last year.

When shows run into venue related acoustical problems (like those at *The Staples Centre in L.A. recently, see clipping below*) these days, the Barbra legend is trotted out. "She can afford anything" they say, "the sound budget is unlimited", and: "her people modify venues until the acoustics are fixed". Critics and punters are increasingly aware of bad sound that is venue related, and venues are quietly fixing problems to avoid cancellations.

Reflections and echoes can render a song unintelligible, and the poor result from concerts at the Sydney Football Stadium have seen this venue bypassed for live music in recent years. Until now.

"We looked at a few venues" says Streisand's LA based sound engineer and designer Bruce Jackson. "Marty Erlichman (Streisand's manager) thought the Football Stadium had the best ambience - whereas Stadium Australia was too big. But we've got a lot of kills".

Kills are production black spots, where sightlines or acoustics are inadequate, and in Sydney at least, a lot of seats are not on sale. They may be seats behind the mix position, or terminally affected by nasty echoes.

Sonic issues arise when venues are built without regard for secondary usage like concerts. Traditional venues like the Football Stadium are full of bare concrete and have glass walls facing the playing area. The shape of a venue often can't be compromised at the design stage, but the finishes can.

"The Colonial Stadium in Melbourne is much better" says Mr. Jackson, "it's world class. But once again it's optimised for house sound, and the glass on the VIP boxes is tilted down towards the ground- good for the in-house PA, but bad for touring PA, which shoots up from the playing ground. The steel in the roof is acoustically treated, and the venue is buying drapes".

Paul Drennan books Colonial Stadium, and he is crucially aware that to attract non sporting events they need to be pro-active. "We have ordered about 9 kilometres of curtains" he reported. "We got Bruce Jackson through here even before we had a contract for Ms. Streisand. We were aware of his reputation and wanted his input".

It's in Sydney where the problems lie, and they are considerable. Mr. Jackson faces a major challenge living up to the mounting pressure to pull a good sound, something that he has been planning for some time. "All outdoor shows are a compromise" he states. "We'll do as good a job as any, and try and get as many things on our side as possible".

EXTENSIVE MEASURES

Central to the efforts to make music intelligible at Sydney Football Stadium for this show was a site survey and test. Acoustics guru David McGrath, one of the founders of Lake Technology, ran over some algorithms at the venues, to show Mr. Jackson where the problems could be minimised.

From his calculations, the stage position was determined. "In Melbourne it looks weird where we have the stage" says Mr. Jackson. But this is central to reducing the problem of reflections, echoes and reverbs.

Then troublesome surfaces, like bare concrete walls and glass windows, were examined. In many cases they will be dressed with a mixture of black cotton or wool drapes. "It's a huge hybrid job", says Staging Rentals' Meri Took. "We spent 3 days at the stadium figuring out how to do it, then we'll have a 5 man team doing 1 week's pre-production. We'll send 2 semi loads of drapes onto site". Then the roof of the stage, supplied by Frank Greer of World Stages International, will be insulated with a felt material, an enormously tricky task.

Echoes and slapback can be greatly reduced by accurate dispersion of sound, something which the latest generation of PA speaker cabinets work towards doing. Throwing a lot of sound where it isn't needed isn't just waste, it usually goes return to sender, a

JACKSON, from page 9

his career when he became Elvis' right hand sound man. As a licensed pilot, Jackson would fly his own single engine plane when he was touring with Elvis and Springsteen.

Elvis even requested Jackson to install the stereo in Elvis' private plane.

Jackson, who still wears the tiger ring Elvis gave him, would fly down to Memphis with all the gear and set tip at Elvis' house, and wait for him to come in to rehearse.

Jackson has come along way in the entertainment industry. All "ears" will be on his craftsmanship when Barbra Streisand performs in Sydney, on March 8 & 10 at the Sydney football Stadium and in Melbourne on March 15 & 17 at the Colonial Stadium Docklands.

SOUND & FURY

The new Staples Center, which has hosted six pop headliners, has left many fans grumbling about its sound. Here's a look at the obstacles to clear sound reproduction at the sports arena and the steps the venue has taken to try to solve the problems:

PROBLEMS	SOLUTIONS
<p>Built-in obstacles to sound reproduction</p> <ul style="list-style-type: none"> ■ Arena was designed primarily for sports, not as an acoustically correct concert hall. ■ Touring acts travel with sound systems that vary in power, quality. ■ Glass divides of 160 luxury suites can reflect sound. ■ Interior has exposed concrete and metal. ■ New venue presents challenges to sound engineers regardless of experience. 	<p>New, existing sound absorption devices</p> <ul style="list-style-type: none"> ■ Horizontal acoustical banners reduce reverberation time and decibel levels. ■ Corrugated, perforated aluminum conceals sound-absorbing insulation. ■ Insulation "clouds" absorb sound above 300-level seats. ■ Seat cushions absorb sound. ■ Sound-dampening material covers face of concrete layers separating suite levels.

Without dampening devices, sound would reflect and reverberate.

Sound-absorption materials lessen reflection and reverberation.

KEY
 Additional and future dampening devices

■ Side seats receive reflected sound: best sound heard directly in front of stage.

Staples Center (330,000 sq. ft.)
 Photos: (330,000 sq. ft.)

■ Staples Center is three times the size of Great Western Forum. Sound reverberates longer in the larger venue.

■ Insulated floor covers ice hockey skating surface.

■ Fabric is draped over hockey boards.

■ Metal railings may replace glass partitions in handicapped seating areas.

■ Acoustical treatments prevent sound from reflecting off concrete surfaces on 100- and 200-levels.

Graphics by PAUL CARRO / Los Angeles Times



**CELEBRATES
25 YEARS
of Design
Development
and Manufacture
of Professional
Sound Products**

With the Release of the
ELEMENT[®] CCCP
Dance Club System
The Highly Versatile
SHOW STACK[®]
Loudspeaker System

M-4000B *Series 2*
4000 WATT MOSFET
PROFESSIONAL POWER AMPLIFIER

SEE US AT
ENTECH
2000
ON STAND
U35

second or so after first created.

The very newest PA designs offer high Q - tight dispersion - boxes and flexible array designs to better aim sound at an audience, instead of a back wall.

i4 PA

For Barbra Streisand's show, the choice of PA couldn't be newer. It's the first time a Clair Brothers i4 system has been used in the Southern hemisphere. Like the V-Dosc and EAW KF 860, this is a line array, where a continual vertical line of components are uninterrupted, and the whole vertical stack acts as one source.

Clair won't say what's inside, just like they didn't talk about the S4 when it first appeared in Australia in 1974. Ironically, Bruce Jackson introduced Clair Brothers to Australia, prior to local operations being taken on by Artist Concert Tours - and later by Jands.

The i4 system is shipped direct to Australia for these concerts, and there is unconfirmed talk of it remaining in Australia afterwards, under the custodianship of Jands - who could sorely use a 'new technology' PA cabinet.

There are three types of cabinet in an i4 array, all apparently externally the same. All three have a rectangular dispersion pattern 90 degrees wide. The difference is in the vertical dispersion, one box does just 2.5 degrees, one 5 and one 10 degrees. This is sensational stuff, because it crucially reduces the inter-cabinet interference that arises when one box covers another's area, particularly in the high frequencies. This is called 'lobing'. "It's where when 2 high frequency drivers reproduce the same fre-



Jackson family shot: Bruce and Terri plus left to right: Aja, Alex and Lindsay.

quency" says Connections' Duncan Fry. "It's like a 'blob' of increased efficiency, at either side of a peak of decreased efficiency".

Bruce Jackson is enthusiastic about the i4, which he has used on only one previous occasion - Barbra's New Year's Eve concert at the MGM hotel in Las Vegas. "It's clean and precise" he says. For this show, four columns of i4 will be flown, in left - right - left - right stereo assignment. Mr. Jackson first started this stereo imaging practice with Elvis.

"The first in the round show was in the Silver dome with Elvis (90,000 seats) where the stage was in the center and Elvis was on top like a wedding cake (with the band on the layer above the

How often do you need improved acoustics on a temporary basis?

SONEX PORTABLE ACOUSTIC MODULES

Portable and demountable modules for temporary absorption wherever and whenever you need it.

- Location Sound Work
- Outside broadcast and/or interview situations
- Home audio, theatre or recording
 - School or college part time music rooms
 - Travelling theatre
- Temporary or part time telemarketing rooms

FOR ALL YOUR SONEX REQUIREMENTS:

Acoustic Answers
Phone 61 2 4736 7723
Fax 61 2 4736 6250

ANNOUNCING PROTOCOL

THE PROPER FOLLOWING OF A SYSTEM



INTERLINK
SYSTEM SOLUTIONS

(02) 9638 0777

7 BRIDGE STREET
RYDALMERE 2116

1 800 638 777

FAX: (02) 9638 0749

speakers and Elvis all alone on the top tier. Here I designed the stage and the sound system. This was alternating L-R-L-R. This in the round configuration predated Yes and Neil Diamond”.

These included the first shows fully ‘in the round’, where a circle of Clair Brothers S4 boxes would be assigned a left-right-left-right stereo image all round. It is for image and dimension, he says. “If you are hard in front of a left cabinet, you get some right as well”.

Bruce Jackson continued his circular L-R-L-R PA configuration for all of Bruce Springsteen’s tours, from Darkness in ’78 to Tunnel of love in 88.

“We did this both indoors and often outdoors where we could....such as the 5 shows at the 80,000 capacity LA Coliseum. The alternating L-R-L gives an unexpected dimension to the music.

The four columns of 20 i4 boxes will be the main PA, and carefully focussed on the audience. Behind the mix position, in a ring about 200’ out from the stage are towers with ‘After Burners’, a Bruce term for customised ultra high frequency drivers. These are time delayed from the main stage PA, and designed to introduce a little of the ‘sizzle’ that is lost over distance.

Then at the 300 foot radius, Bruce has specified delay poles (1” thick!) with Clair Brothers R4 boxes (half an S4) and supplementary high frequency horns.

If anyone can deliver a commercially viable sound mix to paid seats in an extremely difficult venue, Bruce Jackson can. •



Orchestra rehearsals at Raleigh Studios in Manhattan Beach - note they are on a taped out stage. The tables on top are occupied by the music copyists. There were as many as 20 copyists working day and night preparing and changing and changing the arrangements. They would do them in several keys just in case. Barbara would have the high end arrangers come in and let them know to change their hard won arrangements.



Celestion’s new CXi sound reinforcement systems are packed full of

innovative new technologies

like our award-winning

NoBell™ resonance-inhibiting

horn

flares,

advanced CDX1

compression drivers

and ultra-linear, low

distortion bass

drivers.

All of which equips

them rather well for

packing clubs full of

people.



CELESTION

FILL YOUR CLUB WITH CXi SOUND

Distributed by GUET SVL Distribution 87 Mars Road, Lane Cove 2066 Ph: (02) 9418 6029 Fax: (02) 9418 9801

Email: mardelle_collins@guet.com.au

GREATER UNION ENTERTAINMENT

Audio Cables and Pseudo-Science or: cables remystified

Part 3 - Cable Myths. By John Matheson

In the final chapter of this trilogy on cable pseudo-science, I'll wrap up the discussions started in Parts 1 and 2, and throw in a few bits and pieces I've overlooked.

I've claimed that the physics of cables are well understood at a pure science level, if not at the practitioner level. I'll reinforce that claim by saying that a Nobel Prize awaits the discoverer of any new physical laws that explain any audible phenomena in cables that can't be accurately and completely described by the current set of laws!

The Direction For High End Cables

Be very sceptical of anyone or any company who claims to have a different understanding of cable physics or a new or patent design. The chances are they just want your money, nothing more!

Believe it or not, there is one such company who claims to make directional cables, which can be yours for around a mere thousand dollars per meter. To fully understand the fallacy of their claims, we must first appreciate that a sound event never has an absolute value, it is merely oscillations in air pressure around a nominal value. In other words, no sound or piece of music ever ends leaving the air pressure in a room at a higher or lower level than when it began.

It's another way of saying that sound is not a permanent thing. Whatever excursions of sound pressure occur in the positive direction, they are *always* matched by enough sound pressure excursions in the negative direction to counterbalance exactly. Life on planet earth would probably not be possible if this were not true!

At to this the general law of conservation of energy as espoused in Kirchoff's Current Law, which says that the amount of charge

(ie electrons) flowing into a node is *always* equal to the amount of charge flowing out of the node. In other words current can only flow in a *closed* system, or alternatively, charge cannot be created or destroyed.

So what's this got to do with audio cables? It means that for each positive current excursion in one wire, there is an exactly equal and opposite current excursion in the other wire. And it means that for each electron that flows down one wire, that the same electron, or one just like it, must flow backwards again in the *SAME* wire. This is not looking like a good argument for finding directional properties in cables!

But wait, the company who claims the directional property says that the cable conductor is not inherently directional, but becomes directional in the manufacturing process. The process in question is the one when they print arrows on the cable sheath!

If you accidentally connect one of their cables "the wrong way round, no *permanent* damage will be done to the *sound*", they assure their brethren in their FAQ (frequently asked questions). Just connect them the "right" way around and eventually the sound will be repaired. Thank goodness for that! By the way, they make their cables from the same copper as everyone else!

The Truth About The Silver Lining

Another means that cable manufacturers engage to extract money from unsuspecting consumers is the use of silver plated copper conductors. Copper is a pretty good conductor, but as we all know silver is better, 1.06 times better in fact. That's only a 6% improvement!

Rest assured, the manufacturer has only used enough silver to put a silver lining on the copper. That lining is probably only a

entertainment product services
"a whole new world of entertainment products"

UNIVERSAL™
PROFESSIONAL LIGHTING
(Russia) • Intelligent and FX Lighting

sonlite
PROFESSIONAL LIGHTING
(France) • Lighting Software for Intelligent Lighting

OMNITRONIC
(Germany) • Turntables • Mixers • CD Players • Headphones • Accessories

ESFX
(Asia) • Lighting FX • Pinspots • Par Cans • Mirror Balls • Stands • Lamps

catweazle
(Germany) • Catweazle Laser Products

PATRIOT
(Australia) • Sub Cabinets • Mid/High Cabinets • Monitors

ESFX
ENTERTAINMENT PRODUCT SERVICES

12 Bridge Street, Rydalmere NSW 2116 Phone: (02) 9898 0501 Fax: (02) 9898 3366 Mobile: 0407 005 653 Email: disndat@one.net.au

EAW'S **AVALON** INVADES DANCE NATION



AVALON

For the first time ever, a major audio manufacturer has mustered its full engineering resources to create a line of loudspeaker systems designed specifically for high energy dance clubs.

Based on design criteria developed by dance culture participants, the Avalon Series takes a fresh look at the balance of subsystems within a multi-way loudspeaker system. All of EAW's renowned engineering advances - purpose-designed drivers, custom passive filtering, advanced horn design, even VA⁴ technology - are brought to bear in this unique range of systems created just for dancers.

To find out more, call us or visit our web site (www.eaw.com).

The Laws of Physics | The Art of Listening

EAW
 EASTERN ACOUSTIC WORKS

One Main Street, Whitinsville, MA 01588 **tel:** 800 992 5011 / 508 234 5158 **fax:** 508 234 8251 **web:** www.eaw.com
 AUSTRALIAN DISTRIBUTOR: Production Audio Services Pty Ltd, 6-8 Elizabeth St., Richmond, VIC 3121 **tel:** (03) 9415 1585 **fax:** (03) 9415 1595
 EUROPE: EAW International Ltd., **tel:** +44 1494 539090 **fax:** +44 1494 539091

EAW is the worldwide technological and market leader in the design and manufacture of high-performance, professional loudspeaker systems.

couple of molecules thick. In fact, by one such cable manufacturer's own specifications, there is no difference in the resistance of their silver-plated and solid copper cables to three decimal places!

It's hard to see (or hear) the claims of "stunningly open and articulate cable capable of revealing the subtlest dynamics of music" made for silver plated cables. You'd get a greater benefit by chopping 6% off your existing cables than even solid silver cables for that matter, because of the reduced distributed capacitance and inductance.

Many Strands To The Argument

A lot of cable manufacturers emphasise the number of strands in their cables, usually with some vague claims about skin effect. The trouble is that even if skin effect was significant, which in most real life audio applications it is not, the number of strands is irrelevant to the degree of skin effect incurred.

Skin effect is the phenomena whereby at high frequencies only the electrons near the surface of the conductor actually carry current. It does lead to a rise in the resistance of wire as frequency rises, by an amount dependent on the total conductor diameter.

This is true even if the strands are individually insulated. Because the energy in an electric current is actually contained in the electromagnetic field surrounding the conductor, the conductor itself only acts as a guide for the external electromagnetic waves.

Let's consider a practical example. For 10 metres of 2.5 square mm copper loudspeaker cable, the return resistance at DC is 0.15 ohms. At 20kHz where the "skin depth" of copper is approximate 0.4 mm, the resistance will rise to approximately 0.20 ohms.

At 20Hz the insertion loss of the cable for a nominal 8-ohm loudspeaker load will be 0.16dB, at 20kHz it will be 0.21dB, or 0.04dB worse. Now even the golden eared amongst us would have trouble hearing a 0.04dB difference! Even for 100 metres and the difference is still only 0.45dB.

For line level interconnects, where the terminating resistance is likely to be many tens of thousands of ohms, you can forget about skin effect. If there is a tangible benefit in having a large number of conductor strands, it is in the ease of handling. That is of course quite a valid reason for the use of small strands.

A Rose By Any Other Name

Is still a rose! If you see lovely illustrations in a cable manufacturer's catalogue of the magnetic fields around *their* cable compared

to the magnetic fields around *the other* cable, which otherwise looks the same, bear in mind that only the conductor geometry has any bearing on the external magnetic (or electric) fields. Not conductor material, not insulation material and not any special mantras the manufacture repeats in their marketing glossy!

The dielectric properties of the insulation do have a small effect on the lossiness of the cable at very high frequencies. Air (as in pineapple-cored coax or foamed plastic insulation), Teflon and Polyethylene are better than PVC, but you'd be hard pressed to even measure a difference in most audio frequency circuits in professional audio applications. Certainly in very long transmission lines, it could become important.

OK Matho – Stop, Stop! We've Had Enough Just Tell Us What's A Good Cable!

Well, as I started out saying in Part One- An audio cable must interconnect two pieces of audio equipment in a system without introducing any signal degradation of its own, or allowing external influences to degrade the signal. It must be reliable, flexible and able to withstand all sorts of abuse without its signal properties being affected.

Depending on your specific application, the ideal blend of different properties will vary.

Both Belden and Canare have excellent catalogues, which include an overview of the technical parameters involved in cable construction and application. (Net savvy readers can find on-line versions of them at <http://www.belden.com> and <http://canare.com> respectively.)

There are many other good cable manufacturers, including the Australian company Hartland (<http://www.Hartland.com.au>). A sign of a good company is that it doesn't make outlandish or "leap of faith" claims for the performance of their products.

Extraordinary as it may sound, many scientifically conducted double blind tests using experienced listeners have shown that audiophile cables cannot be identified by their sonic performance over cables made on proper engineering principles. But many audiophiles hear it because they believe it!

• jmatheson@adelaide.on.net

MODULAR STAGE BOXES

Need a custom stage box, rack panel, patch panel or distribution box, but just can't find one?

Then look no further than MSB, the modular system that allows the assembly of the most complex panels in minutes.

Oh, and you can leave the tool box at home as this is the only assembly tool you'll need.

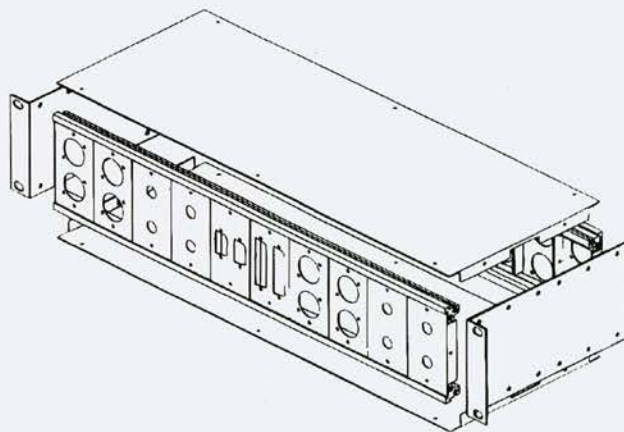

For a free catalogue, please call...

Penn Fabrication Pty Ltd

Ph: (03) 9335 6455

Fax: (03) 9335 6466

ULTIMATE SOUND MACHINES

t.c. electronic®

M3000



STUDIO REVERB PROCESSOR

Incorporating TC's astounding new VSS3™ technology, the M3000 sets a new standard as the best sounding, most versatile and user-friendly professional reverb on the market. By combining precise control of early reflections with a transparent & harmonically magnificent tail, the M3000 delivers a quantum leap forward in the art of reverbation!

Gold Channel



DIGITALLY ENHANCED MIC PRE-AMP

The TC Gold-Channel is the ultimate solution for direct-to-digital recording with a combination of dual high-performance, digitally enhanced mic pre-amps and advanced digital dynamics processing, plus 24-bit converters and virtually every possible combination of digital & analog outputs for direct connection to your digital recorder or DAW.

Finalizer 96K



STUDIO MASTERING PROCESSOR

The latest generation of TC's multi-award winning Finalizer technology, now with 96kHz internal & external processing! This revolutionary dynamics processor puts the world of professional mastering within reach of every studio - large or small. Incredibly versatile yet easy to use, the Finalizer 96K can add unprecedented levels of clarity and punch to your mix.

FIREWORX



DIGITAL EFFECTS PROCESSOR

Want to breathe some fire into your music? Get ready for FireworX! Create just about any effect imaginable - from mild to wild! Choose from stunning palette of effects including Vocoder, Ring Modulation, Synth Generator, Pitch Shifter, Reverse Delays, Fractal Noise, Reverb, Dynamics, Flange, Phase... and more!

Finalizer EXPRESS



STUDIO MASTERING PROCESSOR

The Finalizer Express is the fast, efficient and cost-effective way to turn your mix into a professional master! Based on TC's acclaimed Finalizer(tm) mastering technology, the Express offers all the basic digital processing tools you need to put the world of professional mastering within your reach.

M2000



STUDIO EFFECTS PROCESSOR

TC's design team had "carte blanche" to develop the M2000 as the optimal studio effects processor. Being musicians and engineers, they know exactly what is needed in modern, high-grade effects processing. The M2000's library includes Reverb, Chorus, Ambience, Pitch-Shift, Delay, EQ, De-essing, Phasing, Compression, Gates, Expansion, Limiting & Stereo Enhancement.



For information on the full range of TC Ultimate Sound Machines please contact:

Amber Technology Pty Limited ACN 003 231 187

Sydney Unit B, 5 Skyline Place, Frenchs Forest NSW 2086
 Melbourne Level 6, 10 Queens Road, Melbourne VIC 3004
 Brisbane 220 Boundary Street, Spring Hill QLD 4000
 Western Australia Fairlight On Air Systems
 South Australia Toll Free Customer Service Tel 1800 25 1367

www.ambertech.com.au

Tel (C2) 9975 1211 Fax (02) 9975 1368
 Tel (C3) 9867 7111 Fax (03) 9867 8277
 Tel (C7) 3831 8444 Fax (07) 3831 8455
 Tel (C8) 9479 1711 Fax (08) 9479 1713
 e mail sales@ambertech.com.au

The MDM revolution has ended

Enter the HDR revolution. 24 tracks for ten grand? Here, real soon now!

Unless it's all a giant hoax, you can expect Tascam and Mackie to lead a rush to refit, as new all-in-one 24 track, 24 bit hard disk recorders hit the market sometime around Winter. John Grimshaw went to L.A. to hear the manufacturer's claims....

Mackie's presentation of their 24 track hard disk recorders was a distinct highlight of the NAMM 2000 trade show in LA last month. Their stated design intention was take the best features of MDM's (Modular Digital Multitrack's - existing tape based digital multi-tracks), the ease of use of the classic analogue multi-tracks, and the operational functionality of the current range of DAWs (computer based Digital Audio Workstations), and wrap these features into one box.

If you can believe their presentation, HDR devices like this are going to redefine how multi-tracking will be done in the very near future.

The Mackie HDR is a 24 track, hard disk based machine that is roughly the same size and weight as the current range of 8 track ADATs. A built in 27GB hard drive gives at least 90minutes of continuous recording time in 24 tracks at 24bit/48kHz.

No external computer is required to drive the unit - because with 433MHz Intel chip, 64MB of RAM, ATI Rage 128 Video Card, 100 BaseT Ethernet Card, keyboard and mouse it IS a

computer.

Using the operating system Mackie designed for their Digital 8 Bus desk, and new software for the multitracking ability, the HDR can easily cope with the demands of multi-tracking. Indeed at NAMM I saw - and heard - it pass audio.

Operation of the HDR is straightforward and obvious. It is clear that the designers at Mackie understand that we generally are not interested in reading operation manuals. Most of the critical functions can be accessed by the front panel of the unit, but to get the best out of it, you really should connect a monitor, keyboard and mouse. Using these, you can see the wave-

forms for exact editing and recording. Other DAW like features that have been incorporated include:

- **Leaving Markers at critical moments in the recording.**

Just to make this feature very nifty, after dropping the markers, you can then navigate the recording using the numeric keypad (to jump instantly to the first marker, press the "1" button on the keyboard). You can even set the device to play automatically when jumping to the markers.



- **Selecting a period of time on the time line to loop.**

The selection is quick and easy using the display, and the loop requires no rewinding time. This feature can be used to tweak the EQ on a difficult section, or to continuously retake some section of the recording.

- **Being able to zoom in on the wave form right up to individual samples, or zoom out to see the entire recording.**

- **Quick and easy drag and drop editing between tracks, fading and cross fading.**

Mackie say that the features of many standard DAWs are offset by their inflexibility. They claim that most DAWs take considerable time to set up, and are very susceptible to damage from installations of stray software. Even moving them is frowned upon. As a result, most people who use computer based DAWs are

2400 tracks?

Bob Tudor from Mackie wants to get into the Guinness Book of World Records for the largest number of music tracks playing simultaneously and fully synced.

At NAMM he stated his intention to stack the first hundred production models that roll off the factory floor in March, ethernet 24 channels of audio over to all of them, get 99 guitar cables to sync them all up, and hit play on the first one.

He is very confident that they will all start up exactly in time and fully synced.

Will it happen?

THE FuTuRe OF ReMiX



Finally, effects processors designed to be played like electronic instruments!

Electrix introduces performance-oriented, signal processing that's tailored to the needs of Remixers, DJs, Electronic-Musicians and Producers. Featuring large knobs and buttons that offer real-time, 'hands-on control', Electrix will open new doors of unbridled creativity

The Product line:

- FilterFactory Analog High Order Filter
- WarpFactory The Ultimate Vocoder
- Mo-FX Time Synchronized FX.

"No presets. No menus. Just spin a knob or two and you've got monster sounds."

George Petersen - Mix Magazine- U.S.A.

"The fattest, funkier Vocoder, Resonant Filter Bank and Multi Effects units for both DJ and studio to hit planet earth for generations."

Daniel Duffell - DJ Magazine- UK



Electrix is distributed in Australia by MAJOR MUSIC WHOLESALE
 Unit 1, 146 Oak Road, Kirrawee, NSW 2232 Tel: (02) 9545 3540 Fax: (02) 9545 3584
 Email: info@majormusic.com.au Web: www.majormusic.com.au

www.electrixpro.com



R-1000 Reference series

D.A.S. introduces the New Reference Series. Installation loudspeaker systems with exceptional efficiency, enhanced pattern control and intelligibility, easily adaptable to aesthetically complement the decor of any venue. Engineered from "real world" experience, the Reference Series provides acoustical engineers with the primary tools needed to solve the problems of permanent sound reinforcement installations.



Australian Distributor:
Magna Systems and Engineering

A trading division of Silklore P/L.
 ACN 004 004 997

**Unit 2/28 Smith Street,
 Chatswood, NSW 2067
 Phone: (02) 9417 1111,
 Fax: (02) 9417 2394**

**Web: www.magnasys.com.au
 Email: Sales@magnasys.com.au**

SPECIFICATIONS

Model	R-15	R-18	R-212	R-215	Sub-18	Sub-218
Frequency Response	50 Hz - 20 kHz	35 Hz - 300 Hz	50 Hz - 20 kHz	35 Hz - 20 kHz	35 Hz - 1 kHz	35 Hz - 1 kHz
RMS Power Handling	LF 400 W HF 200 W	500 W	LF 800 W HF 200 W	LF 1000 W HF 200 W	500 W	1000 W
Program Power Handling	LF 800 W HF 400 W	1000W	LF 1600 W HF 400 W	LF 2000 W HF 400 W	1000 W	2000 W
Nominal Impedance	LF 8 Ohms HF 8 Ohms	8 Ohms	LF 4 Ohms HF 8 Ohms	LF 4 Ohms HF 8 Ohms	8 Ohms	4 Ohms
Sensitivity (1W/1m)	100 dB SPL	100 dB SPL	102 dB SPL	102 dB SPL	98 dB SPL	101 dB SPL
SPL at Full Power/Peak	126 dB/129 dB	127 dB/130 dB	131 dB/134 dB	132 dB/135 dB	125 dB/128 dB	131 dB/134 dB
-6 dB Coverage Angles	90° H x 45° V		90° H x 45° V	90° H x 45° V		
Crossover Frequency	1250 Hz	160 Hz	1250 Hz	1250 Hz	160 Hz	160 Hz
Components	LF 15" B-30 HF 1.5" Driver ND-10	18" G-45	12" B-20 1.5" Driver ND-10	2 x 15" G-35 1.5" Driver ND-10	18" G-45	2 x 18" G-45
Dimensions (HxWxD)	71 x 51 x 38 cm	71 x 51 x 72 cm	98.5 x 51 x 41 cm	112 x 56 x 49 cm	74 x 51 x 41 cm	112 x 55 x 48 cm
Weight	33 kg / 72.6 lbs	50 kg / 110 lbs	52 kg / 114.5 lbs	59 kg / 129.8 lbs	36 kg / 79 lbs	59 kg / 130 lbs



The MDM revolution has ended

(continued from previous page)

(quite rightly) very protective about what is done to their systems.

"They are usually glued and screwed in position," says Mackie's Head of Software Development, Bob Tudor. "That can make it a little difficult to pick up your project and take to another studio – and you can usually forget location recordings."

So, what are the advantages of this system over the current range of digital 8 track tape machines? Well, for a start, one box of 24 tracks is far easier to get around with than three boxes of eight tracks. Plus, there are the syncing issues. Tape based 8 track machines typically require a special proprietary sync cable and they are usually not cheap. It takes time to move around the recording – especially if you have multiple decks linked together.

Sometimes, just hitting "play" the machines need time to sync up to each other. This problem was obviously something Bob has had much difficulty in the past with. The system on the HDR only requires a 6.5mm jack to jack guitar cable to make a reliable, frame accurate sync with another HDR, and when you hit play or rec, the HDR responds instantaneously.

Removable media

One of the major ideas Mackie have implemented in this design is the concept of "removable media" at an affordable price. Obviously there are several problems involved in making a hard disk recording device have the ability to "eject" a "tape" of the session. To date, this has been seen by Mackie as a major reason why digital 8 tracks are still in favour.

"Why do DA88's still exist?" asks Bob, "Because you can hit eject! You can take that tape, stick it in your pocket, go to your friend's studio and be able to play that tape in his machine." Mackie has addressed this by making their removable media a 27GB Ultra DMA IDE hard disk, mounted in a special chassis. This was a very carefully considered decision. Bob did this because nothing else was as convenient or inexpensive to implement.

DVD-Ram writes information at 2MB per second, and so requires time to write the disc AFTER you have finished a session (the equivalent of 27GB would take 225minutes!).

(continued on next page)

DAW style editing using optional VDU on Mackie HDR



Tascam MX-2424

24-track, 24-bit Digital HDR (Hard Disk Recorder)

Tascam also previewed at NAMM their new 24 track machine- the MX-2424, designed in cooperation with Timeline.

The MX2424, slated for release during the first quarter of 2000, comes with a built-in nine Gigabyte SCSI hard drive, full 24 channel analogue I/O and two channels of AES/EBU and SPDIF digital I/O, routable to any disk channel. The user has the optional choice of 24 channels of digital I/O in all the standard formats (TDIF, ADAT Optical, or AES/EBU digital) using Tascam designed I/O cards.

The machine is capable of fully multi-tracking 24 channels at 24-bit 48/44.1kHz audio or 12 channels at 24-bit 96kHz audio. The MX-2424 provides video and time code lock capabilities as standard features making it easy to integrate with external workstations. It also resolves to AES/EBU, S/PDIF, word clock, TDIF-1, ADAT optical, SMPTE Time Code (LTC) and video, and chases MIDI Time Code.

An internal drive bay and external SCSI port provide for easy connection of standard disks or backup devices such as hard drives, optical disks, removable SCSI media and DVD-RAM drives.

The unit will be compatible with multiple disk file formats using industry standard, Broadcast Wave (PC) and Sound Designer II (Mac) audio files. The system uses TimeLine's simple Open Track List (Open TL) EDL format which is being made freely available to the audio industry by TimeLine and provides easy compatibility with the Tascam MX-2424 for companies wishing to implement Open TL in their products.

Options for the system include the Tascam RC-2424 remote control unit and the Tascam TL-Sync synchronizer. On-board metering for all 24 channels and extensive editing capabilities are included as standard features. Editing can be performed using the front panel, the RC-2424 remote or from a separate computer running Tascam's ViewNet MX graphical interface software.

The ViewNet MX software application is included as a standard part of the system, and provides a networked graphical interface that allows an external personal computer to control all facets of MX-2424 operation via the unit's built-in fast Ethernet port.

The integrated TL-Bus provides common sample clock and time position signals for multiple Tascam MX-2424 units. Up to 32 MX units may be chained together using the TL-Bus sync connector to provide sample-accurate synchronization across all tracks on all machines. The optional TL-Sync stand-alone synchronizer provides a link to DTRS, ADAT, MMC and Sony 9-pin serial devices as well as TimeLine's Lynx-2 synchronizer modules.

Software updates may be loaded by using the built-in Smart Card flash ROM on the front of the unit: or via the fast Ethernet port when connected to a computer attached to the Internet. •

BASF National TRACKING Guide

ARTIST PRODUCER ENGINEER/PROGRAMMER NOTES

New South Wales

A#Sharp Studio Jeff Cripps +61 2 9153 9988
 Jay Justin Jeff Cripps Jeff Cripps CD
 Villain Jeff Cripps Jeff Cripps CD
 8 Foot Jeff Cripps Jeff Cripps Demo CD
 Emanon Jeff Cripps Jeff Cripps CD
 The Atlantics Martin Cilia Jeff Cripps CD

Aphek Studio Greg Dixon +61 2 9876 8170
 16 TRK 1" Analogue + digital hard disk Soundcraft Ghost console
 Satellite Wish Band Greg Dixon (E) EP
 Lisa Morgan Band Greg Dixon (E) Demo
 Mike Richards Catherine Richards Greg Dixon (E) Drum Instruction CD

Audio Loc Sound Design PTY LTD John Dennison +61 2 9680 7081
 Complete Sound Post for Imax, Feature Film & TV.
 "Angst" Jonathon Green Robert Sullivan Feature Film Mix
 "Solarmax" John Weiley T. Vaccher, J. Dennison Imax Post-
 "Above the Law" Di & Hal McEcroy T. Vaccher, C. Blutters Ch 10 Series
 "Dust" Ivan Sen Tcny, John Patterson Short Film SBS
 "Delinquent Angels" David Blackall John Dennison Documentary

Cloud studios Parris Macleod +61 2 4353 2429
 Fully automated 24 TRK Analogue/24 TRK Digital. Tape/Hard Disk.
 Quake Parris Macleod Parris Macleod Album
 Kytie Burtland Kytie Burtland Parris Macleod/Kytie Burtland Tracking
 Choirboys Parris Macleod/Band Parris Macleod Tracks
 Mother rush Parris Macleod/Band Parris Macleod Demo

Enrel Studio Steve Newton 0418 683 431 Hard Drive Digital, ampex Analog, Adat
 John Williamson John Williamson Steve Newton (E) Tracking Album
 Vince Brophy Steve Newton Steve Newton (E) Mastering
 Errol Gray Steve Newton Steve Newton (E) Tracking

Damien Gerrard Marshall/Elia +61 2 9555 1710 2 Inch 24 + Pro Tods 24 Music Facility
 Not For You Wayne Russell Pilling Album
 Robin Hayde Robin Hayde Russell Pilling Album
 Noogie Marshall Cullen Kristian Hill Tracking Songs
 Spy Vs Dan Marshall Kristian Hill Archiving/Transfers
 Leadlight T J Eckleberg Russell Pilling EP

Festival Studio A Suzanne Hill +61 2 9395 3070 Studio A
 Formal dekka Mark Thomas Mark Thomas Album
 Felicity Hunter Michael Lesso Single
 Danielle Spencer Daniel Denholm Vince Overdubs
 Sean Ikin Paul Commeral Paul commeral Album
 The O'Donnell Brothers Nick Mainsbridge Mixing

Festival Studios Suzanne Hill 61 2 9395 8070 Mastering Suites
 Groove Terminator "Suns nine Single"
 Pancake Day Russell Pilling EP
 Ballpark Russell Pilling Album
 Kylie Minogue Josh Abrahams Remixes
 Kim Salmon Single

Festival Studios Bianka Vukelic 040 724 2651 Fish Tank
 Josh abrahams Josh Abrahams Josh Abrahams Album
 Fountainhead Music Darryl Chute +61 2 9398 7375 Grand Piano + Digital (VST)
 Rosalind Winters Darryl Chute Darryl Chute Album (Celtic)
 Dermot Dorgan Darryl Chute Darryl Chute Album (Satire)
 Lisa Smith Darryl Chute Darryl Chute Album (Pop)
 Rick Carlino Rick Carlino Darryl Chute (E) Album (Musical)
 Maricel Andrew Ward Darryl Chute (E) Single (Pop)

Hindsong Studio David and Lyn Hinds 61 2 8265 7070 Digital Project Studio
 Balance Balance David and Lyn Hinds Album Tracks

Megaphon Studios Shane Fahey 61 2 9550 6576
 Recording Studios; 24 TRK Analog; 3 Huge Recording Rooms
 Steve Clark Steve Clark Shane Fahey
 Alien Christ Shane Fahey
 Christine Anu Stuart Crichton Brent Clark
 Four Play Shane Fahey

> Go to page 44

Version: 1.0.0

EMINENCE DESIGNER

Do-it-yourself Cabinet design - made easy!

State-of-the-art speaker enclosure design program for PCs. Eminence Designer can even suggest a box for your speaker. Either closed, vented, bandpass and passive radiator. Eminence Designer is quick to learn, easy to use and helps you configure the program and guide you through its illustrated online manual. With Eminence Designer, box design is as easy as 1-2-3.

Open Designer Open Online Manual

Design 1

Driver Box Car Foot

Useable with ANY speaker brand!
 Eminence Designer available only from CMI. For more info visit our web site, www.cmi.com.au or Fax: (03) 9315 2244 Ph: 03 9315 2244

R.R.P \$149
 (Includes Post Freight & Handling)

PROEL PROFESSIONAL CABLES

PROEL High Performance Bulk Cable always guarantees absolute signal integrity and importantly, a clear sound. Commitment to high quality cable requires innovative and excellent techniques. Proe offer a wide range of lines to customers and meet the full spectrum of requirements for the rigours of live work and the stability of permanent installations.

PROEL Combination Power & Balanced Line Cable

Combination Power & Balanced Line Cable. 2x22 gauge shielded cables plus 3x15 gauge AC/power conductors.

Microphone Cable 2x24 gauge conductors, 100% copper shield

These and many more varieties of professional audio cable.

Endless Quality

THE SOLUTION TO THE PROBLEM

Distributed in Australia by CMI Professional Products Group
 (03) 9315 2244 www.cmi.com.au

Studio ROUNDUP

The MDM revolution has ended

(continued from previous page)

SCSI hard drives are fast, but at least three times more expensive per gigabyte and the drives are not as big.

Mackie will be supplying media for their machines as pre-formatted drives, loaded into the removable chassis. By pre-formatting the drives, they are saving the user 30min of time, as well as testing the drives before shipping. At around US\$200, the price for these drives will not be much different that the cost of buying the hard drives yourself. Mackie wants the user to think of these hard drives in terms of how many minutes of 24track, 24bit, 48kHz audio it can hold. Currently they intend to have 90min, 60min and 45min hard drives available, with larger drives being released as they become affordable.

Also, while the technology building hard drives continuing to grow, the size of IDE hard drives will grow. Mackie has stated that whatever the current US\$200 drive is will be the one that will ship with the machine. Currently that's a 27GB one. In three months it could be a 34GB one.

One question all of this brings up is that of reliability, because most of us at some time have experienced a hard drive crash of some sort. However, the fact is that hard drives are becoming more and more reliable.

"These hard drives can take up to 7 G's. They get thrown around by couriers. You can throw them on the ground if you want." Laughing, Bob adds, "But I don't recommend it."

The input and output slots take the same cards developed for the Mackie Digital Console Mixer, the Digital 8 Bus. This gives the options of analogue, ADAT, T/DIF, AES/EBU. These slots are designed to take Apogee's I/O cards.

There are numerous control interfaces that come with the standard model. Internal Word Clock, SMPTE, MIDI, Black Burst, and NTSC/PAL sync are all built in. For an additional cost of US\$300, a small remote control panel can control the HDR via a standard Cat 5 UTP with JP45 plugs.

The suggested retail price is US \$4999 (expect to pay less than ten grand in Australia) and the first units are expected to be rolling off the production line as you read this.

Mackie's HDR breaks new ground on so many fronts, it is entirely conceivable that this machine could define the way multi-tracking is designed for years to come.

Mackie's Head of Software Development, Bob Tudor doing the demo at NAMM in LA last month

More Interesting Features

- VU Displays, both on the monitor and the built in LED display, can be made active, even when paused. In this mode, the displays are not monitoring the output, but the amount of signal present at that moment in the sample. As a result, these displays will show the levels present as you jump around searching for "punch in" points.

- 8 "Virtual Tracks" for each track allows for up to eight retakes when recording to any specific track. Then you can either pick the best take, or play a composite take of the best moments from every take.

- True non-destructive editing has a 999 level undo history list. Working much the same way as the undo history in Adobe's Photoshop, this history list allows the user to jump instantly back in the history list.

- Fast forward and rewind functions "ramp up" in speed the longer you stay in the wind mode. This has the effect of being able to stay visually in touch with exactly where you are in the mix. It has the feel of fast winding analogue multitrack.

- 100BaseT ethernet connection allows for backing up, or simply moving audio to an existing network. The copying happens at 5MB per second. Using the supplied CD Rom, a simple double click of an icon interigrates the network, finds the HDR and then lists the files able to be transferred. In addition, because the HDR uses FTP (File Transfer Protocol - which is the same system used on the internet), you can actually use Internet Explorer or Netscape to move the files.

- There is a SCSI card option for the HDR, but Bob can't understand why anyone would want to use it.



WAVECOM JR.

Wireless Audio Video Everywhere COMMunicator

H & C Audio unveils the first high quality inexpensive 2.4 GHz digital wireless transmitter receiver system. Send VIDEO, DATA, AUDIO or SECURITY signals for under \$650 inc. tax. Perfect for live sound or general contracting.

Contact H & C Audio (03) 9876 2333, Fax (03) 9876 2033 Web Site: www.ozemail.com.au/~hcaudio
VIC Dealer: NSCA (03) 9434 1888, Fax (03) 9434 1866 NSW Dealer: Switched On Living (02) 9879 2100



HOT HOT SPECIAL

\$299 inc. tax

Mention this ad
to qualify

PA Power at a feature packed price

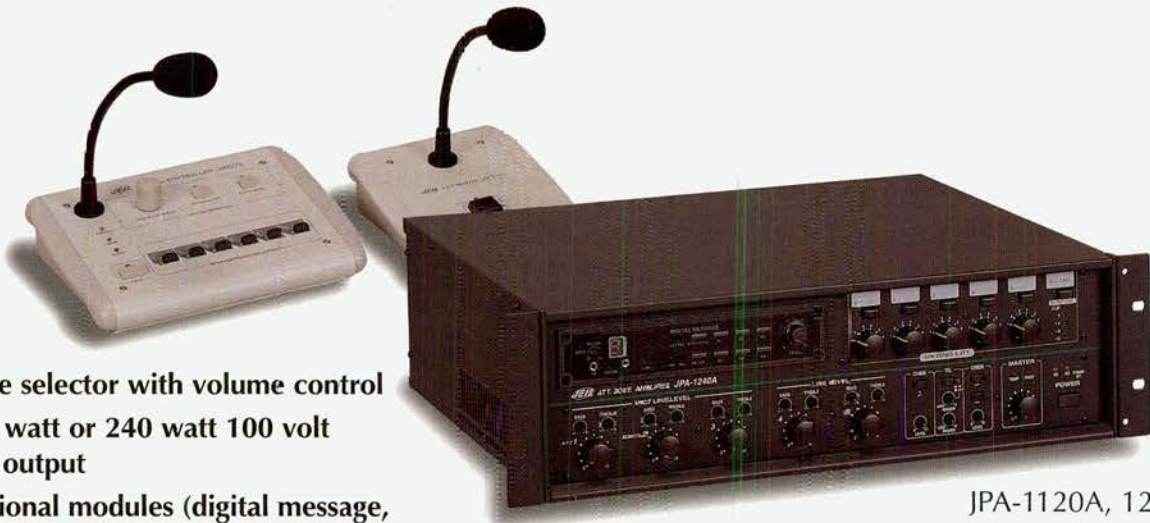

- Zone selector with volume control
- 120 watt or 240 watt 100 volt line output
- Optional modules (digital message, CD Player, AM FM Tuner)
- Remote controllable zone selection from optional microphone

JPA-1120A, 1240A



Proudly Distributed by
AWA audio products

Telephone 1800 642 922 Facsimile 1800 246 262
jeil@audioproducts.com.au



AC400 Unbalanced to Balanced Audio Converter



AC200 Balanced to Unbalanced Audio Converter



PFA200 Program Fail Alarm



MA111 Broadcast Performance Dual Microphone Pre-amplifier with 24V Phantom Power



ADA500 Unbalanced Audio Distribution Amplifier



ADA600 6 Output Balanced Stereo Audio Dist. Amplifier



AS400 4 Input Stereo Audio Switcher



VDA300 3 Output Video Distribution Amplifier



VDA600 Six Output Video Distribution Amplifier



VS400 Four Input Video Switcher

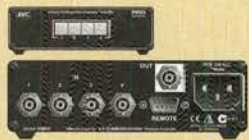

VS450 Four Input Vertical Interval Video Switcher



VS800 Eight Input Video Switcher



VS850 Eight Input Vertical Interval Video Switcher



SVDA600 Six Output SVHS Video Distribution Amplifier



SVS450 Four Input Vertical Interval SVHS Video Switcher



VADA300 3 Output Video & Stereo Audio Dist. Amplifier



VAS300 Three Input Video and Stereo Switcher

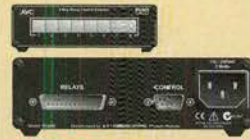

RC800 Relay Controller

Introducing the all new AVC Audio and Video Pro-Solutions Broadcast Box

The Pro-Solutions range for audio and video applications features broadcast quality components and performance in a strong Aluminum Black Box at prices to suit your budget. All models are supplied with IEC power sockets and switchable 115/230VAC power supplies

SOLVE IT WITH A PRO SOLUTION

PRO Solutions
AUDIO VIDEO
BROADCAST BOX

AVC
AUDIO VIDEO
COMMUNICATIONS

25 Irvine Drive, Malaga, WA 6090
Phone +618 9249 6688
Fax +618 9249 6858
Email: sales@avcom.com.au
Web: www.avcom.com.au

Phone, fax or email for your free Pro Solutions colour catalogue

Models subject to change without notice

Studio ROUNDUP

BASF ^{BASF} National TRACKING Guide

ARTIST	PRODUCER	ENGINEER/PROGRAMMER	NOTES
Pitchblak studios "Above The Law"		Leon lucas	2 Tracks
Tropicanna Film Festival	Leon Lucas	Leon Lucas	Opening Track
Emu Beer Film	Songzu	Leon Lucas	Promotional Film
Sunday Telegraph	Songzu	Leon Lucas	Commercial
Powerhouse Studios	Greg Stace +61 2 9318 1220		
Nitocris	Lauchlan Mitchell	Greg Stace	Album
Utopian Babies	Peter Blyton	Peter Blyton	Demos
Dr Rasu	David Moore	Greg Stace	Specials Compilation
Calibre	Russell Pilling	Russell Pilling	Album
9 Volts	Anoy Kent	Gareth Lindsay	EP
R & R Recordings	Robert Zimola +61 2 9672 4494		
3*2*1		Robert Zimola (E)	Demo's
Skeptic	Band	Nick Haertsch	EP
Jargon	Robert Zimola	Robert Zimola (E)	EP
Nick Haertsch	Nick Haertsh	Robert Zimola & Nick Haertsch (E)	Demo's
Rathouse studios	Mark Macedone +61 2 6962 2307	24 TRK Analogue 8 TRK Digital	
Jams	C. Cambell & M. Macedone	E + PR Chris Campell	Album
Rosanne	Chris Campell	E + PR Chris Campell	EP
Fuselage	Chris Campell	E Chris Campell	Demo's
Anne Maree B	Chris Campell	E + PR Chris campell	
Rockinghorse	Anthony Lycenko 61 2 6688 4005		
24 TRK Studer NEVE V Series 48 CHAN ProTools Mix 24.			
The Resin Dogs	Robert Reed	Jeff Lovejoy (E)	Album
Pirol	C. Pyle/A. Lycenko	Michael Worthington (E)	Mastering
Bharti	Artist	M. Worthington (E)	Album Tracking
Skylab	Dave Russell 61 2 9310 4774	Live Band Studio 24 TRK 2 INCH. 32 TRK Digital	
Doug Williams	Gudo	Spaceman (E)	
The Mighty Reapers	Rose Langford	Dave Russell	Single
Lynda Weipeihana	Ricardo	Spaceman (E)	Album
Smoke	Band	Dave Russell (E)	
Juliet OBSESSED	Juliet	Josh Mac Leod (E)	Album
Sound Level	John Soane 61 2 9552 3200	24 TRK DA88 & Paris 16 TRK Hard Disk	
Tim Paxton - The Drugs	Band	Jorden Brebach (E)	Demos
John Needham	John Needham	Jorden Brebach (E)	Demo
Jamie Roberts	Jamie Roberts	Jorden Brebach	Demos
Peter Davis	Peter Davis	Jorden Brebach	Demo
Soundwarp	Maeridith or Bill 61 2 9905 7144	Mastering	
Funky Do Da's	Terry Morton	Meredith Brooks	Album
Otis	Brett McNaughton	Meredith Brooks	Single
Neil Sutherland	Neil Sutherland	Meredith Brooks	TV Theme Music
Sh-Man-Tra	Alex	Meredith Brooks	Double Album
Aesthesia	Matt	Meredith Brooks	Album

Mackie HDR and Tascam 2424 side by side

It is often interesting to see how the stands get placed in a trade show. Usually, it is a purely random situation where vendors simply buy the size stand they want, and the organisers place the vendors in whatever order they can be fitted into the floor space.

Somehow, Tascam and Mackie were placed side by side, and the result was that you could listen in to one demo, and then walk straight across and compare it to their competition. The vendors are all very careful not to directly "bag" their competitors, but those attending cannot help but to look at the differences - especially when you consider that most buyers want to be absolutely sure about something before they spend US\$5000 on it.

So, how did they fare against each other?

Externally they look almost identical, and many functions are very similar. However, there is a clear difference in the design approach to each machine. The Tascam unit is designed to primarily replace and update current multi-track options, whereas Mackie is attempting to upgrade on many fronts how multi-tracking is done. Each of these design goals is a valid direction to take, and it will be up to the consumers to decide which format will become widely accepted. Both machines are excellent in design and implementation, and either would be more than adequate in most situations.

Of Mackie's innovations, it could be that their approach to the "removeable media" (using the cheaper and larger IDE drives) will give it the market edge. Mackie has allowed the user to spend about a third to a quarter of what a Tascam user would spend on hard drives. The Mackie user can take his finished product, sit it on the shelf when it is finished and then buy a new drive for the next session. While a Tascam user can do this, it is obviously not what it was designed to do.

Tascam's big advantage over the Mackie is the "Open TL" format for delivering the contents of a project into another DAW. If your situation demands a system that can dump its content directly into Cubase (or another of the four supported systems), maybe this is the system for you.

I would love to see in twelve months time the Mackie HDR opening an "Open TL" project, and a Tascam MX2424 using Mackie drives. That would make the choice a lot harder.

-John Grimshaw

mobile concert platform

from preferred staging suppliers or **public event group** on 02 8585 5200 - full spec sheet and online booking available on www.publicevent.com.au

public
EVENT
GROUP

community, concert &
outdoor event specialists

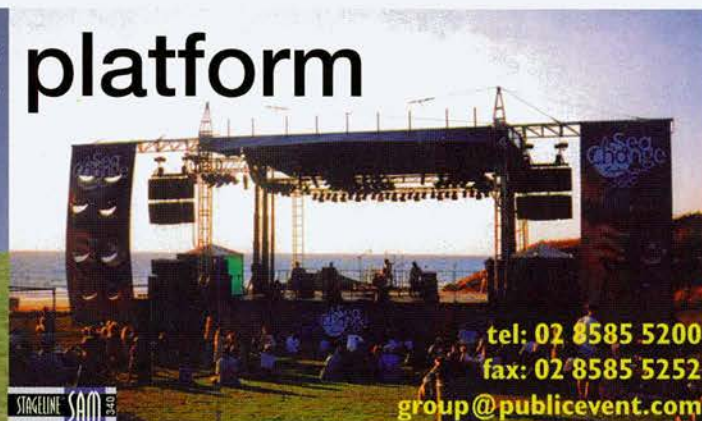

tel: 02 8585 5200

fax: 02 8585 5252

group@publicevent.com

BASF National TRACKING Guide

ARTIST PRODUCER ENGINEER/PROGRAMMER NOTES

301 Mastering Jaqui Espie	+61 2 9211 7301 Mastering Facility		
Regurgitator	Regurgitator	Steve Smart	Single
The Radiators	The Radiators	Don Bartley	Best of Album
Area 7	Lindsay Gravina	Don Bartley	Album
Insurge	Insurge	Steve Smart	Forcoming Album
Nigel Kennedy	Jaz Coleman	Don Bartley	Album
Ian Rilen	James Cruickshank	Don Bartley	Forcoming Album

Top Cat Recording studio Brad Waan +61 2 6628 0232:

Analogue 1" and pro-Tools Mix 24 Plus V50			
Mal and The Longboardersband/Brad Waan		Brad Waan (E)	Album Mixing
Adrian Gawain	Adrian Gawain/Brad Waan	Brad Waan (E)	EP Mixing
ESP	Band/ Brad Waan	Brad Waan (E)	EP Tracking
Cleavage	Band/Brad waan	Brad Waan (E)	EP Mastering
Box	Band/ Brad Waan	Brad Waan (E)	EP Mastering

Trackdown Digital P/L Mike Duffy	61 2 9550 6890 64	Fost + Music	
Moulin Rouge	Bazmark Films	Simon Leadley (E)	Film/Music Edit
Olympic Park/HK Museum of Arts	Torci Lista (E)	De mian Candusso (E)	Audio Guides
Sportsworld Theme/Ch. 7	L Buckfield/N. Hamilton	Tim Ryan (E)	TV Theme
Falcon Eddie & Ratsparl	Gabriel Corbin	Tim Ryan (E)	Single (Mix)
Hi 5	Chris Harriott	Kathy Naunton (E)	TV Songs

Troy Horse Mickey Levis	+61 2 9314 1749	Analogue 24 TRK	
Directions In groove	Scott Saunders	Mark worral	Album Live Mixes
Compost		Mark worral	Album Mixing
Swell		Mickey Levis	EP and Mixing
Fire Hose reel		Dave trump	Album
Big Wally	Dave Henderson	Dave Trump	EP and Mixing

Velvet Sound Recording Studios Dave McGunn	61 2 267 2915		
24 TRK Analogue & 64 ch. Prottoolsv5.0 MixPlus			
Adam Freeland	Adam (PR)	Tony Wall (E)	Album Mixing
Ezmerelda	Marty Hailey	Adrian Grigorieff (E)	EP Track and Mix
Sean Ikin	Paul Gommersal	Paul Gommersal	Album Tracking
Max 22	Artists PR	Tony Wall (E)	EP tracking
Tashka	Steve James	Adrian Grigorieff (E)	Album Track & Mix
Otis	Brett McNaughton	Toby Wall (E)	EP Track & Mix

Wirra Willa studios Will Rout	+61 2 9605 1203		
Michael Robert Peaker	Michael Robert Peaker	Will Rout (E)	Album
Fab Manzini	Fab Manzini	Will Rout (E)	Album
Acumen	Acumen	Will Rout (E)	Album
Lindsay 'Blue' Burke	Lindsay Burke	Will Rout (E)	Album
Brian + Herschel	Brian + Herschel	Will Rout (E)	Album

Victoria

AD STUDIO	+61 3 9372 6828	Multitrack Music Production and Mixing	
Lindsay Buckland	Lindsay Buckland	Brett Taylor	Album
Lindsay Buckland	Lindsay Buckland	Brett Taylor	Album

BackBeach recording Mark Rachelle	+61 3 5988 6948		
Class A Automated 2 Inch Recording/Mixing Studio.			
Madison Avenue	Van/Coates	Mark Rachelle	Album
Mach Pelican	Band	D.W Norton	
Alchemist	Band/ D.W Norton	D.W Norton	Album
Abremelin	Band/ D.W Norton	D.W Norton	Album
New Buffalo	K.Rice	K.Rice	EP

Crystal mastering Joe carra	+61 3 9326 2318	CD Mastering Facility	
Madison Avenue	A.Van/Coats	Joe carra (E)	Mastering Singles
Kieran Tolhurst	Kieran Tolhurst	John Ruberto	Mastering Album
Through to China	Band	Joe Carra (E)	Mastering Album
Colleen Hewett		John Ruberto	Mastering Single
Alchemist	Agius/D.W Norton	John Ruberto	Mastering Album

Metropolis Audio Sally Rodrigues	03 9696 2111		
48 TRK Digital & MF3 + Digital Workstation			
Australian Open 2000	Meghan Tozer	Simon Pavone (E)	Radio Campaign
Rock The Millenium	Melke	Ern Rose (E) & D. Brady (E)	Radio Camp.
FooFighters, You Am I, Killing Heidi	MCM AUStreo	Ern Rose (E)	TV Specia /Webcast
Dog Woman	John Clifford White	Scott Hemming (E)	TV Series
Optus	Chong Lim	Joug Brady (E)	Sound Design

CMI

See Wot's Hot!

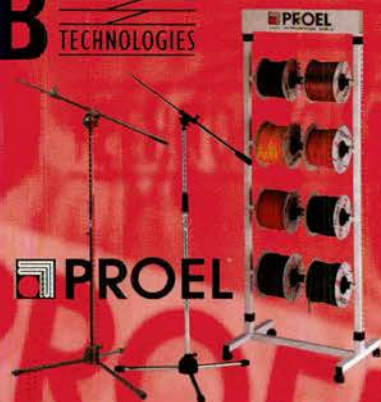

PEAK Audio
HIGH PERFORMANCE SYSTEMS

CMI @ stand 08. ENTECH 2000

For more information visit our web site
www.cmi.com.au
or contact CMI on Ph 03 9315 2244 Fax: 03 9315 2115

Studio ROUNDUP

BASF National TRACKING Guide

ARTIST	PRODUCER	ENGINEER/PROGRAMMER	NOTES
Sound Around The Mobile/The Front Room	Trevor Cronin	+61 3 9531 3891	
Bat	Malcombe Battersby	Trevor Cronin	Mastering
Belmonts	Band	Chris Dickie	Tracking
Andrew De Silva	Band	Trevor Cronin	Live Recording
Sci-Sonic	Donian West	Trevor Cronin	Mastering
Leo Rosneiz	Band	Trevor Cronin	Live Recording
True Form recording	Neil Gray	+61 3 9391 0907 24 TRK	Digital, Analogue and Hard Disk
Jambo Jambo	Leona Chishala	Neil Gray (E)	Album
Squair	Band/Neil	Neil Gray (E)	Live to Dat
One	Band/Neil	Neil Gray (E)	EP
Startroopers	Band/Neil	Neil Gray	Demo
Wombat Road Recording Studios	Barrie Clissold	61 3 5145 4204 24 TRK	Digital + 16 Analog
Angie Higgins	G Gross	Barrie Clissold (E)	Album (CD)
John Mazur	John Mazur	John Mazur	Album (CD)
John Turner/Stewart Thorpe	S Thorpe	B Clissold	Album (CD)
Jade McNeill	Barry Clissold	Barry Clissold	Demo (CD)
Brialalong Bush Band	Clissold/Rose	Barry Clissold (E + PR)	Album

South Australia

Disk edits catherine Linke 08 8340 1377
Audio Mastering and Post Production. CD and Casette Manufacturing.

Katrina Caton	Neville Clark	Mastering/CD Manufacturer	
Chalk Music	Shane Heatie	Neville Clark	Mastering/CD
Various	Big Boot Records	Neville Clark	Mastering/CD
Goose	Band	Neville Clark	Mastering/CD
Anomaly	Band/Mick Wordley	Neville Clark	Mastering/CD
Mixmaster Productions	Mick Wordley	+61 8 8278 8506	
Yak Spit	Matt Henley	Mick Wordley	EP
Timothy	Geoff Stapleton	Mick Wordley	Album
Turquoise	Mick Wordley	Mick Wordley	Album

Queensland

Domenic Sound	Shane Hughes	+61 7 3216 5187 32 TRK	Adat and Pro-Tools
Goran Sedlar	Shane Hughes	Shane Hughes	Album
Rhonda Tant	Shane Hughes	Shane Hughes	Album
Janie Shrapnel	Shane Hughes	Shane Hughes	Album
David Goodwin	David Goodwin	Shane Hughes	Album
Steve Tracey	Shane Hughes	Shane Hughes	Single
Grevillea Studios	Bruce Jacobson	+61 7 3262 8422	Recording, Mixing & Mastering Studios
Kathy Francis	Tony Byrne & Kathy Francis	Tony Byrne	Tracking For Album
Big Band	Bruce Jacobson & John Hoffman	Bruce Jacobson	Album/Mastering
Ross Lovell	Ross Lovell	Matt Bodman	Album Tracking
Brisbane State High	Big band Andrew Firth	Bruce Jacobson	Mastering
Vandersound Studios	Eric Vandersande	61 7 5546 8100	All Digital + Valve OLR HDR
Ian Francis	Eric Vandersande + Ian	Andrew Hines + EV	Album Edit

Atoned	Eric Vandersande	Chris O'Connell	Demo/ Master
Oz Deli	Andrew Hines + Toby Masterton	Toby Masterton	Demo Edit
Mitsubishi	Eric Vandersande	J. Ellwood & K. Cowen	TV AD Post

Western Australia

Pinnacle Recording Studio	Anthony B Kitson	61 8 9382 1582 24 TRK 2	Inch AMEK ANGELA
AC/DC Tribute Album	ABK	A. B Kitson (E)	Album
Skining	Anthony B Kitson & Band	Anthony B Kitson (E)	Album
Half Cut	Anthony B Kitson	Anthony B Kitson (E)	Album
PC Thug	Anthony B Kitson & Band	Anthony B Kitson (E)	EP
Autopilot	Band	Anthony B Kitson (E)	Pre Production
Planet Sound studios	+61 8 9382 2211 2 x SSL Music Studios		
Nigel Kennedy & Prague Symphony Jaz	Coleman	H. Nicholson/J Villani	Mix for Decca
Hank Marvin	Hank Marvin	Les Williams	Mix for Polydor
Frenzee	Boyd Wilson	Boyd Wilson/J Villani	Single
Lee Bradshaw	Lee Bradshaw	J Villani	Album
Poons Head Rob and Sam	+61 8 9339 4791	Boutique music Recording/48 TRK	
Sheva	Tim and Rob	Rob Grant (E)	Singles
Gutterville Splendor Six	Tim and Rob	Rob Grant (E)	EP
Chapter V	Maurice Flavel and Rob Grant	Rob Grant (E)	EP
Down and Under	Chris Giles and Rob Grant	Rob Grant (E)	Demos
Superscope	Rob Grant and Kevin Borrosu	Rob Grant (E)	EP
Revolver Vic Manfrin	+61 8 9272 7503 32 TRK	Automated Analog and Digital	
Afterburn	Ben Glatzer	Ben Glatzer	Tracking
Bordello	Band/ Ben Glatzer	Ben Glatzer	Tracking
Cartman	Band/ Ben Glatzer	Ben Glatzer	Mixing
Big Boss Beaver	band	Vic Manfrin	Demos
Autopilot	band/Laurie Sinagra	Laurie Sinagra	Tracking
Satellite Recording Studio	Darren Halifax	61 8 9470 4003	ProTools 64 TRK 24 Bit
Another Light	Band	Darren Halifax	Album
Monterey Lodge	Andrew Neal	Andrew Neal	Album
Mistress Suzannah	Suzannah	Darren Halifax	Three CD Set
No Flowers No Wedding	DressBand	Darren Halifax	Album
The Dingo's	Breakfast	Eric Kowarski	Eric Kowarski
Album			

YOUR BASF TRADE SALE OUTLETS:

NSW:	Audio Visual Designs (02) 9281-2444
	Silver & Ballard (02) 9439-5355
	Independent Tape Services (02) 9436-0666
	MT&A (02) 9310-2799
VIC:	CATS (03) 9529-3177
	Chapple Tape (03) 9580-6620
	DEX Audio (03) 9372-2266
	MT&A (03) 9819-6455
SA:	Adelaide Tape Duplicators (08) 8212-7111
	Pro Media (08) 8276-6793
WA	Ausmag (08) 9314-1953
	Pro Copy (08) 9375-3902
QLD:	Musiclab (07) 3252-2138
	Tek (07) 3239-4000



BASF YOUR MUSIC IS SAFE WITH US

FOR A SOUND DEAL!

PAstuff.com

25 YEARS EXPERIENCE IN PRO PA

Connections

H&P

Hire & Production Directory March 2000

A.C.T
COMPLETE PRODUCTION COMPANY

Abroad entertainment

PO Box 102
 WODEN ACT 2606
 PH: +61 2 6291 9060
 FAX: +61 2 6291 4606
 KEY STAFF: Rod Fishwick: Director

BETTER MUSIC (PRODUCTIONS)

29-31 Colbee Court
 PHILIP ACT 2606
 PH: +61 2 6282 3199
 FAX: +61 2 62825436
 EMAIL:

gary_woodbridge@bigpond.com
 KEY STAFF: Gary Woodbridge: Operations Manager, David Bowron: Production Manager. Canberra's leading suppliers of staging, drapes, lighting and audio. Latest equipment and best people for corporate theatre, concert, festival, musical theatre and outdoor shows. Major corporate events our specialty. Equipment includes Studiocolours, Cyberlights, Technobeams, ETC pars and profiles, Jands Echelon, Event and HP dimmers. Audio includes DDA Q2 console, EV X-Array, SX300, EVP3000 amplifiers, Klark Teknik, Drawmer & TC Electronic processing, Vega radio mics and complete backline hire.

Concert Productions Canberra

26 Fellows Street
 LATHAM ACT 2615
 PH: 0407 073 212
 FAX: +61 2 6254 0743
 EMAIL: concert.productions@actonline.com.au
 KEY STAFF: John McFarlane: Boss: Production Co-ordinator, Lynette McFarlane: Bigger Boss (Financial Adviser)

Nova Multimedia

Unit 1, 41-45 Tennant Street
 Fyshwick ACT 2609
 PH: +61 2 6239 2722
 FAX: +61 2 6239 2723
 WEB: www.novamultimedia.com.au
 KEY STAFF: Nick Novas: Director, Emmanuel Vavoulas: Director, Tommy Powel: Production-Operations.

Sound Advice Australia

Unit 4/4 Wiluna Street
 Fyshwick ACT 2609
 PH: +61 2 6280 8777
 FAX: +61 2 6280 8177
 EMAIL: sn@internet.com.au

KEY STAFF: Stephen Nano: Production Manager, Norman Konte: Sales Manager, Brett Fraser: Hire Manager.

Sound Workshop

67 Wilshire Street
 DICKSON ACT 2602
 PH: +61 2 6247 6203
 FAX: +61 2 6247 8508
 EMAIL: sound.workshop@interact.net.au
 KEY STAFF: Tony Brighton: Director, Valia Palmer: Office Administration, Ben Brighton: Operations Manager.

A.C.T
AV/STAGING

Staging Connections

11 Whyalla Street
 Fyshwick ACT 2609
 PH: +61 2 6280 6990
 FAX: +61 2 6239 1530
 EMAIL: gdesira@stagingconnections.com.au
 WEB: www.stagingconnections.com.au
 KEY STAFF: George Desira

A.C.T
OTHER

ICR Computer rentals PTY LTD

3/19-25 Kembla Street
 FYSTICK ACT 2609
 PH: +61 2 6239 3844
 FAX: +61 2 6239 3890
 EMAIL: icr@bigpond.com.au
 WEB: www.icr-rentals.com.au
 KEY STAFF: Paul De Heer: ACT Branch Manager.

N.S.W.
COMPLETE PRODUCTION COMPANY

32 Hundred Lighting

Unit 3/ 7-9 Kent Road
 MASCOT NSW 2020
 PH: +61 2 96393 1777
 FAX: +61 2 9693 5980
 EMAIL: 3200LXCS054@aonenet.au
 KEY STAFF: Ian Reed: Managing Director, Antony Reed: Operations Manager, Nadia Elouaer: Administrator

Action Sound Pty. Ltd.

Unit 13/378 Parramatta Road
 HOMEBUSH WEST NSW 2140
 PH: +61 2 9764 6622
 FAX: +61 2 9764 6633
 EMAIL: tony@actionsound.com.au
 WEB: www.actionsound.com.au
 KEY STAFF: Tony Hystek: Managing Director, Alanna Ewin: Administration Manager, Brett Lunney: Audio Engineer

AM Staging

73A Burrows Street
 ALEXANDRIA NSW 2015
 PH: +61 2 9550 6511
 FAX: +61 2 9550 6802
 EMAIL: simon@amstaging.com.au
 WEB: www.am.com.au
 KEY STAFF: Mike Emerson: Manager, Simon Crossett: Hire Manager



Avsound Productions

28 Roseberry Street,
 BALGOWLAH NSW 2093
 PH: +61 2 9949 9000
 FAX: +61 2 9949 9444
 EMAIL: info@avsound.com.au
 WEB: www.avsound.com.au
 KEY STAFF: Matt Kline: Director.

Band-Tech Productions

PO Box 322
 MORTDALE NSW 2222
 PH: +61 2 9580 4838
 FAX: +61 2 9580 4838
 KEY STAFF: Willi Gutwein: Sole Proprietor, Graham Rowison: Systems Engineer/Monitor Engineer, Webby Murr: Lighting Design.

Black Express Light And Sound

717 Princess Highway
 TEMPE NSW 2044
 PH: +61 2 9559 4363
 FAX: +61 2 9558 4923
 EMAIL: candrews@blackexpress.com.au
 WEB: www.blackexpress.com.au
 KEY STAFF: Con Andrews: Managing director, Angelo Andrews: General Manager, Nick Megisidis: Hire manager.



BLACKSHEEP CORPORATE EVENTS

22-36 Mountain street
 ULTIMO NSW 2007
 PH: +61 2 9212 7222
 FAX: +61 2 9212 7018
 EMAIL: events@blacksheep.com.au
 WEB: www.blacksheep.com.au
 KEY STAFF: Ben Alcott: Managing Director, Jenny Martin: Client Manager, Amanda Martin: Client Manager
 Blacksheep Events provides a unique partnership to meet clients corporate strategic communications needs. From conception to completion, Blacksheep offers creative solutions for all levels of corporate presentations, launches, sponsorships, awards, gala dinners, promotions and conferences. Blacksheep offers 11 years of experience to ensure your event is even better produced than you ever imagined.

BLM PRODUCTION SERVICES

PO Box 225
 MENAI CENTRAL NSW 2234
 PH: +61 2 9541 4888
 FAX: +61 2 9541 4199
 EMAIL: info@blm.com.au
 WEB: http://www.blm.com.au
 KEY STAFF: Brian Walsh: Production Manager, Ian Jackson: Hire Manager, Jason Fripp: Tech Manager.
 Professional Lighting and Audio Sales, Service, Hire and Production. Without questio, Sydney's leading Dance Party service provider.
 Genuine discounts for Schools and Amateur theatre groups. Club Installations, Concert, Corporate, Fashion Parades, Festivals, Raves, Storefronts, Theatre and Touring. Professional Friendly service 7 days a week. Let BLM bring your next event to life. On Time, On Budget!

Coastal Sound Systems

Cemetery Road
 BOWRAVILLE NSW 2449
 PH: +61 2 6564 7517
 FAX: +61 2 6564 7517
 EMAIL: coastal@nui.net.au
 KEY STAFF: Tom Benson: Owner

CORPORATE PRODUCTIONS AND EVENTS PTY LTD

5 Julius Street, FAIRFIELD WEST NSW 2165
PH: +61 2 9711 7833
FAX: +61 2 9711 7838
EMAIL: mail@cpe.au.com
WEB: www.cpe.au.com
KEY STAFF: Michael Pepper: Director, Brett Gibson: Director, Mark Gibson: Director.
We provide high quality Production Management and Audio Visual services to corporate and government organisations.
When your serious about the success of your next special event, call the team at Corporate Theatre Productions and Events, because it's all said and done, experience shows.

Daylight International

4 Bridge Road
GLEBE NSW 2037
PH: +61 2 9660 7755
KEY STAFF: Steve Lowe: Production Manager, Mathew Dorman: Hire Manager

dB Sound

DB SOUND (NSW) PTY LTD

7 Bridge Street
RYDALMERE NSW 2116
PH: +61 2 9638 0777
FAX: +61 2 9638 0749
FREECALL: 1800 638 777
EMAIL: hire@dbsound.com.au
WEB: www.dbsound.com.au
With a collective thirty years experience, you can rely on us for short or long term hires of Audio, Lighting and Video Equipment—dry hire through to complete planning and production services. We Hire, Sell and Service many leading brands of professional equipment, including Australian Monitor, Beyerdynamic, dbx, Interlink System Solutions, JBL, Shure and Soundtracs.



**DMC LIGHTING AND SCUND PTY LTD
SLURRY HILLS**

613A Elizabeth Street,
SLURRY HILLS NSW 2016
PH: +61 2 9319 7177
FAX: +61 2 9319 2685
EMAIL: general@dmclightingandsound.com.au
WEB: www.dmclightingandsound.com.au
KEY STAFF: Adam Nevzat: Executive Consultant, Steve Fielli: Installation Manager, Ken Jackson: Hire Manager.
DMC Specialise in:
Sales-Leading Brands and Second Hand Equipment
Short Term Hire
Permanent Hire
Production
Repairs
dm: Finance
DMC are today's and tomorrow's solution to your lighting and sound requirements. We are the undisputed leader in providing lighting and sound to Sydney's clubs, bars, venues, promoters, DJs and everyday groov-ers. No job is too large or too small.
dmc Lighting and Sound RYDALMERE
12 3ridge Steet,
RYDALMERE NSW 2116
PH: +61 2 9898 3336
FAX: +61 2 9898 9966
KEY STAFF: Bill Williams

Elite Sound & Lighting

263 Auckland Street
BEGA NSW 2550
PH: +61 2 6492 3549
FAX: +61 2 6492 3549
EMAIL: elitesound@one.net.au
KEY STAFF: Darren Russell: Owner/Head of Audio, Rock O'Shea: Head LD, Louise Russell: Office Manager.

Entertainment Installations

401 Manns Road
WEST GOSFORD NSW 2250
PH: +61 2 4324 3873
FAX: +61 2 4324 5878
EMAIL: info@entertainmentinstallations.com.au
WEB: www.entertainmentinstallations.com.au
KEY STAFF: Neale Mace: Manager, Caroline Mace: Accounts, Glenn Stewart: Hire/Production.

Events Highlands

Kangaloon Road
BOWRAL NSW 2576

Phone: +61 2 4861 6733
Fax: +61 2 4227 6344
Key Staff: Stuart Udy: Production, Gerado: Sales Manager, Maxine Rava: Office Manager.

Feral Studios

24 Agnes Avenue
QUEANBEYAN NSW 2620
PH: +61 2 6299 3244
FAX: +61 2 6297 C244
EMAIL: replicate@eisa.net.au
KEY STAFF: Jon Robertson: Production and Recording Manager, Ryks Hesbit: Lighting Director, Faylene Robertson: Administration

Innovative Lighting & Sound

4 Chuter Ave
MONTEREY NSW 2217
PH: +61 (0)416 145 500
FAX: +61 (0)416 146 501
EMAIL: jeremy_koch@bigpond.com
KEY STAFF: Jeremy Koch: Manager/Design, Brendan Sadgrove: Technician/Musician.

Jands Production Services Pty Ltd

40 Kent Road
MASCOT NSW 2020
PH: +61 2 9317 5200
FAX: +61 2 9693 5451
WEB: www.jands.com.au

JAZZRIGHT
Production Services

Jazzright Production Services

30 Romani Parade
MATRAVILLE NSW 2036
PH: +61 2 9311 1197
FAX: +61 2 9661 7110
EMAIL: mailjazz@jazzright.com.au
WEB: www.jazzright.com.au
KEY STAFF: John Perez: Owner/Director, Keith Clarkson: Operations Manager.

L&W TECHNICAL SUPPORT SYSTEMS

1/566 Gardeners Road,
ALEXANDRIA NSW 2014
PH: +61 2 9667 0362
FAX: +61 2 9667 0266
EMAIL: jtlee@bigpond.com
KEY STAFF: John L'Estrange: Managing Director, Shayne Kemp: Operations Manager, Leigh Randall: Systems Engineer.
L&W Technical Support Systems offers an extensive range of services including audio, visual, staging and corporate lighting. Whether it be live production, corporate presentations, promotions or dry hire, you will be impressed with our dedication to excellence. For the best result, first time, call our professional staff who are happy to discuss your event.

Laservision Macro-Media Pty Ltd

50 Carters Road
DURAL NSW 2158
PH: +61 2 9658 1000
FAX: +61 2 9651 3217
EMAIL: laser@laservision.com.au
WEB: www.laservision.com.au
KEY STAFF: Steven Johnson: Presentations Manager, John Eustace: Marketing Manager, Loraine Eadie: Marketing/Sales Coordinator.

Macsound Theatrical Supplies

11 Plane Avenue
URALLA NSW 2358
PH: 1800 684 090
FAX: 1800 684 911
EMAIL: info@macsound.com.au
WEB: www.macsound.com.au
KEY STAFF: Bruce Mc Rae: Proprietor, Julie Vanry: Sales Consultant, Chris Estrich: Technical Consultant.

PANANDA ENTERTAINMENT

PO Box 1351
DARLINGHURST NSW 1300
PH: +61 2 9517 4482
FAX: +61 2 9517 4482
KEY STAFF: Pan Wells: Director, Amanda McCulloch: Sales Manager.
Since last issue: We have produced several events for our increasing clientele. Our unique style of corporate dance party is a relief from the Hum-drum these events can become. If your company involves or markets to a younger thinking people, why not give us a call? We know how to party and what a Great party is.

public EVENT GROUP

PUBLIC EVENT GROUP

PO Box K1347
HAYMARKET NSW 1240
PH: +61 2 8585 5200
FAX: +61 2 8585 5252
EMAIL: group@publicevent.com.au
WEB: www.publicevent.com.au
KEY STAFF: Gina Hall: Event Producer, Laura Hampton: General Manager, Don Gunn: Production manager.
Collaborating with communities and corporations in the creative development, production and funding of events and festivals.
Our advanced and cost-effective concert platform is available from your preferred staging supplier or contact us. Use our website for a range of online forms designed to assist you cost your event of obtain information on product options.

Saltbush Productions

36 William Street
AVALON NSW 2107
PH: +61 2 9918 6668
FAX: +61 2 9918 6668
EMAIL: saltbush@spin.net.au
KEY STAFF: Duncan Ritchie: Partner,
Alan Moran: Partner

T-Pac Sound & Lighting P/L

141 Edwin Street
CROYDON NSW 2132
PH: +61 2 9799 7219
FAX: +61 2 9799 7219
EMAIL: T.pac@bigpond.com
KEY STAFF: Michael Orland: CEO, Jim
Piesley: Audio Foreman, John Pascoe:
Lighting Foreman.



THE MUSIC BOX PTY LTD

451-455 Liverpool Road,
ASHFIELD NSW 2131
PH: +61 2 9797 1800
FAX: +61 2 9797 1600
EMAIL: hire@themusicbox.com.au
WEB: www.themusicbox.com.au
KEY STAFF: Vic Leto: Production
Manager, Greg Leto: Financial
Director, Alan McIlvride: Technical
Production Manager.
We carry an extensive range of
Audio, Lighting, Video, Draping
and Staging systems. Our services
include driveway hire, speaker and
electronic repairs, full production
facilities including crewing,
transport and equipment. Call us
for your next event requirements
be they corporate, theatre, live or
live studio broadcast.
Music Box doing it Better.

The PA People

432 Liverpool Road
ENFIELD NSW 2136
PH: +61 2 9642 5344
FAX: +61 2 9642 5738
EMAIL: hire@cstgroup.com.au
KEY STAFF: Nick Eltis: Hire Manager,
Rodger Rapsey: Sales Director, Chris
Dodds: Managing Director.



THE SHOWCORP GROUP

32 Punch Street,
ARTARMON NSW 2065
PH: +61 2 9966 9888
FAX: +61 2 9966 9444
EMAIL: sales@showcorp.com.au
WEB: www.showcorp.com.au
KEY STAFF: Colin Baldwin:
Company Principal, James Barton:
Showcorp Video Solutions, Roger
Hind: The Great Outdoor Lighting
Company.
Showcorp Production Services has
over 26 years experience in
production design and manage-
ment. Our knowledge of all facets
of production for product
launches, conferences, exhibi-
tions, installations, themed
dinners, concerts and any kind of
special event, guarantees that
whatever your needs we can
provide professional support and
equipment. Our range of audio
visual, lighting, themed and
corporate sets, sound systems,
staging and digital video editing is
the most comprehensive available.

N.S.W.

LIGHTING

Black Express Light And Sound

717 Princess Highway
TEMPE NSW 2044
PH: +61 2 9559 4363
FAX: +61 2 9558 4923
EMAIL:
candrews@blackexpress.com.au
WEB: www.blackexpress.com.au
KEY STAFF: Con Andrews: Managing
director, Angelo Andrews: General
Manager, Nick Megisidis: Hire
manager.



BYTECRAFT®

BYTECRAFT THEATRICAL PTY LTD

5/31 Bridge Road
STANMORE NSW 2048
PH: +61 2 9950 3955
FAX: +61 2 9519 3977
EMAIL:
bytecraft@bytecraft.com.au
WEB: www.bytecraft.com.au
KEY STAFF: Durham Ritchie:
National Sales Manager, Paul
Rigby: Hire Manager, Rowan
Trundle: Assistant Hire Manager.
Professional range of Theatre,
Film/TV and Concert Lighting
Equipment, including lanterns,
control desks, dimmers, pre-rig
truss, ICON and High End Moving
Lights, Skytracker searchlights,
Pani projectors, rigging and
motors and the latest safety gear.
Full lighting production services
are available from design to bump
out including crew and operators.

CHAMELEON TOURING SYSTEMS PTY LTD

Bourke Road
ALEXANDRIA NSW 2015
PH: +61 2 9310 5222
FAX: +61 2 9310 5511
EMAIL: tony@chameleon-
touring.com.au
KEY STAFF: Pip Robinson: Senior
Production Manager, Brad Gander:
Production Manager, Scott Bason:
Production manager.
Chameleon Touring Systems
specialise in the Lighting of
Corporate Presentations, Special
Events, Theatre Shows, Musicals,
Exhibitions, Film and TV. The
company provides an innovative
professional service in the design
and installations of all their
productions.
Chameleon have a comprehensive
range of Luminaires and effects,
Control systems, Searchlights,
Trussing and Motors and Special
effects equipment from all the
leading manufacturers including:
Altman, ETC, Clay Paky, High End,
Martin, Selecon, and White Light
that is available for HIRE as
individual components or
PRODUCTION.

Comet Lighting P/L

5 Ramsay Street
HABERFIELD NSW 2045
PH: +61 2 9716 6093

FAX: +61 2 9799 8930
EMAIL: samcomet@primus.com.au
WEB: http://home.primus.com.au/
samcomet
KEY STAFF: Sam Bienstock: Gaffer.

Concert Lighting Systems Australia Pty Ltd

23 Hickson Road,
MILLERS POINT NSW 2000
PHONE: +61 2 9247 3222
FAX: +61 2 9247 3229
EMAIL: info@clsa.com.au
KEY STAFF: Trevor Lloyd: Director,
Matt Hansen: Hire Manager.



Electric Sunshine

PO Box 126
EXETER NSW 2579
PH: +61 2 9550 6000
FAX: +61 2 9550 5500
EMAIL: lights@electricssunshine.com.au
WEB: www.electricsunshine.com.au
KEY STAFF: Phil Cullen: Reception and
Service, Scott Russell: Workshops and
Logistics, Lee Hardaker: Design and
Programme.

Events Sales

47 Auburn Street,
WOLLONGONG NSW 2500
PH: +61 2 4229 6010
FAX: +61 2 4227 6644
KEY STAFF: Stuart Udy: Production
Manager, Gerado Ceres: Sales
Manager, Maxine Rava: Office
Manager.

Grafton Lighting

5/890 Bourke Street,
WATERLOO NSW 2017
PH: +61 2 9698 7777
FAX: +61 2 9698 7776
EMAIL: graftons@idx.com.au

Just listen to what our
customers say

"NICE!" "BIG!" "GOOD!"
"HAPPY!" "CHEAP!" "YES!"
"MORE!" "PLEASE!"

ARE YOU EXCITED?
**ELECTRIC
SUNSHINE**
We do lighting hire & design.

Ph: (02) 9550 6000
Shy? Fax us (02) 9550 5500 or
lights@electricssunshine.com.au

KEY STAFF: Robert Vanderent: Sales,
Adam Burbury: Hires, Kevin O'Connell:
Production.

LASER SPECIAL EVENTS

140 Sutherland Street
PADDINGTON NSW 2021
PH: +61 2 9328 1815
FAX: +61 2 9327 8986
EMAIL: lse@lse.com.au
WEB: www.laserspecialevents.com.au
KEY STAFF: Tracy Bourke: Director,
Geoff Rose: Director
Reputation for Innovative work in
Australia and Overseas. Latest
Laser Scanning Systems and
Motorized Mirror Effects.
Interactive Performance using
Lasers, Lighting and Video. Solo,
Aerial and Ensemble Performance
using Mirror Costumes, Floating
Fabric and Fibre Optic Costumes.
Clients include Qantas, British and
Korean Governments, Bayer
(Special Event Week Award
Winner), Johnny Walker (ISES
Award), LNG12 Conference (MIAA
Meeting of the Year 1999)

PH: +61 2 9658 1000
FAX: +61 2 9651 3217
EMAIL: laser@laservision.com.au
WEB: www.laservision.com.au
KEY STAFF: Steven Johnson:
Presentations Manager, John Eustace:
Marketing Manager, Lorraine Eadie:
Marketing/Sales Coordinator.

Lightmoves Technologies (NSW) Pty Ltd

631 Parramatta Road
LEICHHARDT NSW 2040
PH: +61 2 9560 0000
FAX: +61 2 9568 2333
EMAIL: lightec@lightmoves.com.au
KEY STAFF: Jonathan Ciddor:
Managing Director, Paul Cwen:
Project Director, Gavin Noywens: Hire
manager.

Lots of Watts

2 Bridge Street
RYDALMERE NSW 2116
PH: +61 2 9638 0302
FAX: +61 2 9638 0331
EMAIL: hire@lotsofwatts.com.au
WEB: www.lotsofwatts.citysearch.com.au
KEY STAFF: Philby Lewis: Hire
Manager.

Macro-Media Marketing Pty Ltd

The Cottage, 50 Carters Road
DURAL NSW 2158

PH: +61 2 9658 1339
FAX: +61 2 9651 3217
EMAIL: marketing@macro-
media.com.au
WEB: www.macro-media.com.au
KEY STAFF: John Eustace: Business
Development Manager, Lorraine Eadie:
Marketing/Sales Coordinator, Brett
Starkley: general manager.

Premier Lighting

Factory 10, 111 Moore Street,
LEICHHARDT NSW 2040
PH: +61 2 9550 9233
FAX: +61 2 9564 3734
EMAIL: premier@premierlighting.com.au
KEY STAFF: Philip Planer: Manager.

Ray Standen Audio P/L

c/o Kennards Self Storage, 159 Airds
Road, LEUMEAH NSW 2560
PH: +61 2 4627 8300
FAX: +61 2 4627 7555
EMAIL: raystandenaudio@bigpond.com
WEB: www.users.bigpond.com/
raystandenaudio/
KEY STAFF: Ray Standen: Director, Jill
Standen: Office Manager, Paul &
Peter: Technicians.



THE GREAT OUTDOOR LIGHTING COMPANY

32 Punch Street,
ARTARMON NSW 2064
PH: +61 2 9966 9111
FAX: +61 2 9966 9444
EMAIL:
sales@greatoutdoorlighting.com.au
KEY STAFF: Colin Baldwin and
Roger Hind: Company Principals
Primary Activity: Special Effects,
search Lights, architectural and
projection lighting.
The widest most powerful range
of search lights, architectural and
projection lighting in Australasia.
State of the art special effects
lighting ideal for a wide range of
applications including festivals,
concerts, building openings,
product launches, sporting events,
advertising, celebration events,
promotions and film & television
applications.

Laservision Macro-Media Pty Ltd

50 Carters Road
DURAL NSW 2158

HIRE AWARENESS AUSTRALIA

HIRE AND RENTAL ASSOCIATION OF AUSTRALIA



NATIONAL CONFERENCE & EXHIBITION

15th - 17th
MAY 2000

GOLD COAST 2000

CONRAD JUPITERS
BROADBEACH, GOLD COAST
QUEENSLAND, AUSTRALIA

Conference Secretariat:

Tel: +61 7 3851 4777 Fax: +61 7 3851 4788
Email: hraql@bigpond.com

Building a brighter future

CLS SYDNEY
23 Hickson Road
Millers Point NSW 2000
Ph. 02 9247 3222
Fax. 02 9247 3229

DLS MELBOURNE
63 - 65 Kingsway
Southbank Vic 3006
Ph. 03 9682 6111
Fax. 03 9682 6777

email: info@crisa.com.au
web: www.crisa.com.au
ACN 605 422 319

N.S.W.

AUDIO



Anything Audio

Unit 12, 5 Parsons Street
ROZELLE NSW 2039
PH: +61 2 9818 8000
FAX: +61 2 9818 8011
EMAIL: anyaudio@idx.com.au

Audio & Recording Aust. Pty. Ltd.

36-38 Daphne Street
BOTANY NSW 2019
PH: +61 2 9316 9935
FAX: +61 2 9666 3752
EMAIL: sales@audiorecording.com.au
WEB: www.audiorecording.com.au
KEY STAFF: Ian Richardson: Managing Director, Garry Hall: Systems Engineer, David Richardson: Systems Engineer.

**Audio Sound Centre Rentals,
A Division Of PANAVISION**

1 McLachlan Avenue
ARTARMON NSW 2064
PH: +61 2 9901 4455
FAX: +61 2 9438 5069
EMAIL: rentals@audiosound.com.au
WEB: www.audiosound.com.au
KEY STAFF: Nick Blaxell: Audio Manager, Nic Godoy: Audio Rentals Assistant.

Black Express Light And Sound

717 Princess Highway
TEMPE NSW 2044
PH: +61 2 9559 4363
FAX: +61 2 9558 4923
EMAIL: candrews@blackexpress.com.au
WEB: www.blackexpress.com.au
KEY STAFF: Con Andrews: Managing Director, Angelo Andrews: General Manager, Nick Megsidis: Hire manager.

Centrestate Sound and Lighting

82 Margaret Street
ORANGE NSW 2800
PH: +61 2 6362 0587
FAX: +61 2 6361 7875
EMAIL: centrestate@netwit.net.au
KEY STAFF: Allan Brown: Proprietor.



Coda Audio Services

Unit 16, 888 Bourke Street,
CAMPERDOWN NSW 2050
PH: +61 2 9557 2111
FAX: +61 2 9557 2366
EMAIL: codamail@coda-audio.com.au
WEB: www.coda-audio.com.au
KEY STAFF: Philip Murphy: Director, Michael Wilkie: Director, Leigh Williams: Administration.

**Compact Monitor Systems Aust.
Pty. Ltd.**

218 Prices Circuit
WORONORA NSW 2232
PH: +61 2 9521 8115
FAX: +61 2 9521 8116
EMAIL: richardson@compactmonitor.com
WEB: www.compactmonitor.com
KEY STAFF: Bill richarson: Managing Director, Michell Richardson: Administration, Gerry Wilkins: Secretary.



DB SOUND (NSW) PTY LTD

7 Bridge Street
RYDALMERE NSW 2116
PH: +61 2 9638 0777
FAX: +61 2 9638 0749
FREECALL: 1800 638 777
EMAIL: hire@dbsound.com.au or sales@dbsound.com.au
WEB: www.dbsound.com.au
KEY STAFF: Garry Hawkins: Hire, Philip Brainwood: Sales, David Boehm: Service.

With a collective thirty years experience, you can rely on us for short or long term hires of audio, lighting and video equipment – dry hire through to complete planning and production services. We hire, sell and service many leading brands of professional equipment, including Australian Monitor, Beyerdynamic, dbx, Interlink System Solutions, JBL, Shure and Soundtracs.

Events Sales

47 Auburn Street,
WOLLONGONG NSW 2500
PH: +61 2 4229 6010
FAX: +61 2 4227 6644
KEY STAFF: Stuart Udy: Production Manager, Gerado Ceres: Sales Manager, Maxine Rava: Office Manager.

Lightsounds Leichhardt

776 Parramatta Road
LEWISHAM NSW 2049
PH: +61 2 9560 0300
FAX: +61 2 9560 0301
EMAIL: sales@lightsounds.com
WEB: www.lightsounds.com
KEY STAFF: Steven Vourma: Hire Manager.

Lightsounds Parramatta

318 Church Street
PARRAMATTA NSW 2150
PH: +61 2 9893 9922
FAX: +61 2 9633 5533
EMAIL: sales@lightsounds.com
WEB: www.lightsounds.com
KEY STAFF: Brett Atkin: Store Manager.

Lightsounds Sydney City

170c Riley street
DARLINGHURST NSW 2011
PH: +61 2 9357 1771
FAX: +61 2 9331 1515
EMAIL: sales@lightsounds.com
WEB: www.lightsounds.com
KEY STAFF: Edgar Badaway: Store Manager.

Lots of Watts

2 Bridge Street
RYDALMERE NSW 2116
PH: +61 2 9638 0302
FAX: +61 2 9638 0331
EMAIL: hire@lotsofwatts.com.au
WEB: www.lotsofwatts.citysearch.com.au
KEY STAFF: Philby Lewis: Hire Manager.

Macro-Media Marketing PTY LTD

The Cottage, 50 Carters Road
DURAL NSW 2158
PH: +61 2 9658 1039
FAX: +61 2 9651 3217
EMAIL: marketing@macro-media.com.au
WEB: www.macro-media.com.au
KEY STAFF: John Eustace: Business Development Manager, Loraine Eadie: Marketing/Sales Coordinator, Brett Starkley: General Manager.

**Night-Shift Entertainment
Services PTY LTD**

164 Liverpool Road
ENFIELD NSW 2136
PH: +61 2 9744 7777
FAX: +61 2 9744 7798
EMAIL: info@nightshift.com.au
WEB: www.nightshift.com.au
KEY STAFF: Steven Tanou: Managing Director, Emilio Pereira: Hire/Operations Manager, Tina Medaglia: Marketing Executive.

Norwest Productions

26 Constitution Road
RYDE NSW 2112
PH: +61 2 9809 0244
FAX: +61 2 9809 0647
EMAIL: office@norwestproductions.com
WEB: www.norwestproductions.com
KEY STAFF: Chris Kennedy: Manager, Damon Hartley: Administration, Dave Rennie: Operations manager.

NSW Sound And Light

33 Canyon Drive
STANHOPE GARDENS NSW 2768
PH: +61 2 9629 7181
FAX: +61 2 9629 7181
EMAIL: nswsound@value.com.au
WEB: www.ausrock.com-nswsound
KEY STAFF: Neil Waite: Owner/Operator, Sharryn Waite: Operations manager, James Camilleri: Assistant.

Ray Standen Audio P/L

c/o Kennards Self Storage, 159 Airds Road
LEUMEAH NSW 2560
PH: +61 2 4627 8000
FAX: +61 2 4627 7555
EMAIL: raystandenaudio@bigpond.com
WEB: www.users.bigpond.com/raystandenaudio/
KEY STAFF: Ray Standen: Director, Jill Standen: Office Manager, Paul & Peter: Technicians.

Revolver Audio

937 Bourke Street,
WATERLOO NSW 2017
PH: +61 2 9698 3288
FAX: +61 2 9699 9570
KEY STAFF: Lee Conlon: Manager



STUDIO FX

Ground Floor Entrance,
Cnr Waine & Riley Streets,
DARLINGHURST NSW 2010
PO Box 696
DARLINGHURST NSW 2010
PH: +61 2 9281 0272
FAX: +61 2 9281 02 76
EMAIL: gear@studiofx.com.au
WEB: www.studiofx.com.au
KEY STAFF: David Lackey, Jim Taig
Pro Audio Sales and Hire:
Studio Fx has been providing
Australia's leading audio
professionals with the best in
classic retro, analogue and digital
pro-audio hire equipment since
1983. Our clients include the
majority Australia's top studios,
producers, engineers, program-
mers, DJ's, composers and
broadcast professionals.
Our comprehensive hire range
now includes everything from
mics, pre-amps, headphones, Eq,
gates, compressors, limiters,
samplers, effects devices, mixing
and recording consoles, digital
recorders, monitors and blank
media; from specialist individual
items right through to entire
location recording and mixing
packages from 8 to 48 tracks. Our
range of hire stock professionally
selected for superior sound
quality, reliability, ease of use and
pro-user demand.
All hire equipment can now be
provided individually or as
packages. (e.g.) Drum kit
microphone packs, headphone-
monitoring kits, 24 track digital
ADAT or Hi8 systems etc.
Please call for details.

N.S.W.

AV/STAGING

AM Staging

73A Burrows Street
ALEXANDRIA NSW 2015
PH: +61 2 9550 6511
FAX: +61 2 9550 6802
EMAIL: simon@amstaging.com.au
WEB: www.am.com.au
KEY STAFF: Mike Emerson: Manager,
Simon Crossett: Hire Manager



BIG CITY PRODUCTIONS SERVICES PTY LTD

26 Mitchell Road
ALEXANDRIA NSW 2015
PH: +61 2 9318 2354
FAX: +61 2 9319 3929
EMAIL: bigcity@bigcity.net.au
WEB: www.bigcity.net.au
KEY STAFF: Brian Findlay: Director,
Alistair Peters: Director
Staging and Access Floor
available for sale or hire.
Ideal for exhibiton Stands,
Corporate, Schools, Film, TV,
Theatre Sets, etc.



BIG PICTURE AUSTRALIA PTY LTD

Unit 2/25, Dickson Ave,
ARTARMON NSW 2064
PH: +61 2 9439 0177
FAX: +61 2 9439 0377
EMAIL: office@bigpicture.com.au
WEB SITE www.bigpicture.com.au
KEY STAFF: Dennis Murphy:
Director, Joe Bonanno: Director,
Stephen Pippett: Trainee.
Event Video and television
production services and facilities,
EFP single camera and multi-
camera "Rack Style" outside
broadcast systems with full
complement of lenses, VTF's and
accessories.
Arena style large projection
screens with Barco projection Avid
Media Composer 1000 Digital
non-linear editing.
Friendly, experienced, capable
personnel. Get Serious and get the
BIG PICTURE!



BLACKSHEEP TECHNICAL SERVICES PTY LTD

22-36 Mounta n street
ULTIMO NSW 2007
PH: +61 2 9212 7222
FAX: +61 2 9212 7018
EMAIL:
techservices@blacksheep.com.au
WEB: www.blacksheep.com.au
KEY STAFF: Rowan Holland:
Technician, Richard Cause:
Technician, Geoff Grist: General
manager.
Dry hire or complete supply and
operation of scund, lighting and
staging equipment to meet the
needs of small to medium corporate
presentations and promotions.
Brand name equipment, expertly
maintained and delivered on time
and working as it should. Call for our
current rental equipment catalogue
and details of our Guarantee of
Excellence!

Centrestage Systems

5 Russell Avenue
LINDFIELD NSW 2070
PH: +61 2 9415 8000
FAX: +61 2 9415 8800
EMAIL: info@centrestage.net.au
WEB: www.centrestage.net.au
KEY STAFF: Alex Gourlay: General
Manager, David Penney: Production
Manager, Sally Gourlay: Sales/
Marketing



Clipsal Vision Super Screens Pty Ltd

State office in
PADSTOW NSW 2200
PH: +61 8 8445 9600
FAX: +61 8 8268 6755
EMAIL: superscreen@clipsal.com.au
WEB: www.clipsalvision.com.au
KEY STAFF: Angelo Russo: Sales and
Marketing, Cam Johnson: Operations,
Geoff Ellery: Managing Director.

Electroboard Pty Ltd

20 Atchinson Street,
ST LEONARDS NSW 2065
PH: +61 2 9433 4444
FAX: +61 2 9433 4401
EMAIL: rentals@electroboard.com.au
WEB: www.electroboard.com.au
KEY STAFF: Narelle Bray: Rentals Co-
ordinator.

EUROVISION PTY LTD

98 Wyndham Street
ALEXANDRIA NSW 2015
PH: +61 2 9699 9921
FAX: +61 2 9699 9967
KEY STAFF: Philip Royston:
Director, Adam Meszaros:
Operations Manager, Damien
Foxton: Technical Manager.
Complete range of audio visual
services to event producers and
for corporate events, seminars,
conferences, exhibitions and
special events.

Events Highlands

Kangaloon Road
BOWRAL NSW 2576
Phone: +61 2 4861 6733
Fax: +61 2 4227 6644
Key Staff: Stuart Udy: Production,
Gerado: Sales Manager, Maxine Rava:
Office Manager.



GEARHOUSE SYDNEY

22-34 Rosebery Ave,
ROSEBERY NSW 2018
PH: +61 2 8344 1200
FAX: +61 2 8344 1299
EMAIL: sydney@gearhouse.com.au
WEB: www.gearhouse.com
KEY STAFF: Russell Bennett:
Managing Director, Chris Murphy:
Lighting Manager, Phil Clark: Sales
Manager.
As the world's leading provider of
presentation and staging services
the Gearhouse Group consists of
specialist divisions focused on
your event success. Corporate
Presentations, Themeing and Set
building, Specialist Lighting and
Sound, Exhibitions, Equipment
sales, Design and Installation,
Concert video and Lighting
combine to ensure that Gearhouse
has the right solution for you.

N.S.W.



HAYCOM STAGING

1 Lawrence Street,
ALEXANDRIA NSW 2015
PH: +61 2 9557 1666
FAX: +61 2 9557 4744
EMAIL:
info.syd@haycomstaging.com.au
WEB:

www.haycomstaging.com.au
KEY STAFF: Annette Talrico:
General Manager, Phil Clarke:
Technical Manager, Ves Campion:
Account Manager, Gabrielle
Tregonning: Sales Executive.
Established in 1973, Haycom
Staging has grown to become the
largest independantly owned
audiovisual staging company in
Australia, having consolidated a
reputation for superior service and
expertise in the area of large
screen projection and corporate
theatre.

We can supply Technical
Directors, show crew and all
equipment, including the famous
Hughes cinema quality projectors.
Offices in Sydney, Melbourne,
Brisbane, Adelaide and Perth.

public EVENT GROUP

PUBLIC EVENT GROUP

PO Box K1347
HAYMARKET NSW 1240
PH: +61 2 8585 5200
FAX: +61 2 8585 5252
EMAIL: group@publicevent.com.au
WEB: www.publicevent.com.au
KEY STAFF: Gina Hall: Event
Producer, Laura Hampton: General
Manager, Don Gunn: Production
manager.
Collaborating with communities
and corporations in the creative
development, production and
funding of events and festivals.
Our advanced and cost-effective
concert platform is available from
your preferred staging supplier or
contact us.
Use our website for a range of
online forms designed to assist
you cost your event of obtain
information on product options.

Staging Connections Coffs Harbour

Pacific Bay Resort
COFFS HARBOUR NSW 2450
PH: +61 2 6658 0410
FAX: +61 2 6658 0420
EMAIL:
cspeedy@stagingconnections.com.au
WEB: www.stagingconnections.com.au
KEY STAFF: Chris Speedy

Staging Connections Sydney

68-72 Lilyfield Road,
ROZELLE NSW 2039
PH: +61 2 9818 2555
FAX: +61 2 9818 3703
EMAIL:
pkolevas@stagingconnections.com.au
WEB: www.stagingconnections.com.au
KEY STAFF: Peter Kolevas

Staging Connections Wollongong

2-14 Cliff Road,
NORTH WOLLONGONG NSW 2500
PH: +61 2 4226 9555
FAX: +61 2 4227 1149
EMAIL:
kthompson@stagingconnections.com.au
WEB: www.stagingconnections.com.au
KEY STAFF: Kim Thompson



STAGING RENTALS

1 Pyrmont Bridge Road
CAMPERDOWN NSW 2050
PH: +61 2 9519 6300
FAX: +61 2 9519 6489
EMAIL: peter@staging.net
WEB: www.stagingrentals.com.au
KEY STAFF: Meri Took: Managing
Director, Peter Bliss: General
Manager, Lisa Sykes: Customer
Service Manager
Your next event could be great.
Creating it should be fun too.
Australia's leading specialist
rental staging company providing
friendly professional service and
quality products, First class,
creative design service. Quality
drapes, staging, rigging, sets and
specialty items. Production
management and installation.
Free site inspections. Your
complete staging service. We
guarantee your complete
satisfaction.

SYDNEY DANCE FLOORS & STAGING

PO Box 31
ANNANDALE NSW 2038
PH: 0500 500 585
FAX: +61 2 9777 2202
Sydney's only stage and floor
specialists.
Indoor/Outdoor, height adjustable
all – terrain stages.
American Red Oak Flooring.
Polished Black/White Floors.
Hire, Sales, Repair, Lease.
In-Venue Management of Stages
and Floors.
Sole NSW/ACT Distributor of the
World Famous Stageright Product
Range.



Technical Direction Company

36-42 Chippen Street,
CHIPPENDALE NSW 2008
PH: +61 2 9698 5588
FAX: +61 2 9698 5533
EMAIL: tdc@tdc.com.au
KEY STAFF: Michael Hassett:
Managing Director, Catherine Hassett:
Director, Jon Okeby: Sales Manager.



Videoplus Pty Ltd

9 Hill Street
LEICHHARDT NSW 2040
PH: +61 2 9552 6066
FAX: +61 2 9552 3400
EMAIL: info@videoplus.com.au
WEB: www.videoplus.com.au
KEY STAFF: Keith Wooton: Sales and
Marketing Manager, Gabrielle
Florentine: Account Manager, Michael
Nutt: Account Manager

N.S.W.

OTHER



BLACKSHEEP AVIATION AERIAL VIDEO SERVICES

22-36 Mountain street
ULTIMO NSW 2007
PH: +61 2 9212 7222
FAX: +61 2 9212 7018
EMAIL: aviation@blacksheep.com.au
WEB: www.blacksheep.com.au
KEY STAFF: Ben Alcott: Chief Pilot
Blacksheep owns and operates its
own helicopter, wh ch is specially
fitted with broadcast cameras,
and recorders to shoot economical
aerial pictures whenever you need
them. Our pilots are trained to
understand the pictures you need
must contain the WOW factor
while still working within your
budget. Call for details of our
aerial camera rates.



BLACKSHEEP BROADCAST LIVE EVENT TELEVISION PRODUCTION

22-36 Mountain street
ULTIMO NSW 2007
PH: +61 2 9212 7222
FAX: +61 2 9212 7018
EMAIL: broadcast@blacksheep.com.au
WEB: www.blacksheep.com.au
KEY STAFF: Ben Alcott: Director,
Amanda Martin: Client Manager
Blacksheep Broadcast offers live
event television quality coverage
using three digital widescreen
cameras and the latest support
equipment. Professional camera
operators will ensure "every frame
is a Rembrandt" as your event is
switched and edited live to huge
screens, videowalls and tape. VHS
copies are available. Call for our
information pack.

N.S.W.



BLACKSHEEP VISION VIDEO PRODUCTION AND POST PRODUCTION

22-36 Mountain street
ULTIMO NSW 2007
PH: +61 2 9212 7222
FAX: +61 2 9212 7018
EMAIL: vision@blacksheep.com.au
WEB: www.blacksheep.com.au
KEY STAFF: Natalie Wilson: Video Manager, Dael Oates: Video Editor, Geoff Grist: General Manager
Blacksheep Video will script, shoot, produce and edit your next corporate video or presentation so that you are totally delighted. We have two digital Media 100 edit suites, available for in house hire and one completely portable edit suite for location work. Call for your comprehensive Blacksheep Video Services introductory pack.

ICR Computer Rentals PTY LTD

8/28 Smith Street
CHATSWOOD NSW 2067
PH: +61 2 9417 0666
FAX: +61 2 9417 8933
EMAIL: icr@bigpond.com.au
WEB: www.icr-rentals.com.au
KEY STAFF: Riad Fruat: National Sales & Marketing Manager, Ramzy Khui: NSW Branch Manager.

Image Design Technology P/L

33 - 35 Alleyne Street
CHATSWOOD NSW 2067
PH: +61 2 9417 4924
FAX: +61 2 9417 8945
EMAIL: info@idt.com.au
WEB: www.idt.com.au
KEY STAFF: Gerry Wilkins: Managing Director, Michael Hearden: Sales Executive, Brad Cornish: Account Manager.

Lightmoves Technologies (NSW) PTY LTD

631 Parramatta Road
LEICHHARDT NSW 2040
PH: +61 2 9560 0000
FAX: +61 2 9568 2333
EMAIL: lighttec@lightmoves.com.au
KEY STAFF: Jonathan Ciddor: Managing Director, Paul Owen: Project Director, Gavin noywens: Hire Manager.



ORACLE LASER PRODUCTIONS

5/222 Headland Road,
DEE WHY NSW 2099
PH: +61 2 9938 4466
FAX: +61 2 9938 4504
EMAIL: paulm@oracle.com.au
WEB: www.oraclelaser.com.au
KEY STAFF: Paul Mazlin: Director, Jon Spencer: Sales, Paul Morrison Manufacturing.
Asian Office: Oracle Laser Productions Singapore, 6 Temasek Boulevard #09-01 Surtec City Tower 4, Singapore 038 985
PH: +65 333 8458
FAX: +65 333 8436
Chris Sifton: Director.
EMAIL: chris@oraclelaser.com.au
Oracle Specialise in laser system hire and sales for Corporate Events, Product Launches, Outdoor Spectaculars, laser billboarding, water screens, night clubs and dance parties in addition to Theme Park shows and multimedia installations both Australia wide and overseas. Large range of systems available from 50mW to 60W for hire, long term hire or sale including the new TZ Bazooka.



POLLARD PRODUCTIONS

5 Bay Street
BOTANY NSW 2019
PH: +61 2 9700 1233
FAX: +61 2 9316 6727
EMAIL: rigs@pollardprod.com.au
KEY STAFF: James Ring: managing Director, Chris Ford: Operations Manager.
With years of industry experience, Pollard Productions specialises in rigging and practical SFX as well as steel and alloy foundation for the film, entertainment and exhibition industries. Our emphasis remains on Quality, Reliability and Safety. Our hire department can help you with chainmotors, chainblocks, truss, slings, turntables, pneumatic rigs, effects and flying hardware and much more. Pollard Productions - Rigging to Sydney's premier venues.

Ray Standen Audio P/L

c/o Kennards Self Storage,
159 Airds Road
LEUMEAH NSW 2560
PH: +61 2 4627 8000
FAX: +61 2 4627 7555
EMAIL: raystandenaudio@bigpond.com
WEB: www.users.bigpond.com/
raystandenaudio/
KEY STAFF: Ray Standen: Director, Jill Standen: Office Manager, Paul & Peter: Technicians.

SHOWCORP VIDEO SOLUTIONS

SHOWCORP VIDEO SOLUTIONS

32 Punch Street,
ARTARMON NSW 2065
PH: +61 2 9966 9888
FAX: +61 2 9966 9444
EMAIL: sales@showcorp.com.au
WEB: www.showcorp.com.au
KEY STAFF: Colin Baldwin: Company Principal, James Barton: Manager.
A comprehensive range of shoot-and-edit packages for both corporate and live event productions. From slide or video production to full multi-media capabilities, our aim is to provide multimedia solutions at affordable rates. Our multi-media suite utilises the latest technology, including digital broadcast quality hardware and the safest editing software available.

tp Events

13/51 Spring Street
BONDI JUNCTION NSW 2022
PH: +61 2 9386 9494
FAX: +61 2 9386 9490
EMAIL: events@tpvents.com.au
WEB: www.tpevents.com.au
KEY STAFF: Danny Yezerski: Managing Director, Brigid Paton: Event Director, Avi Anger: tp Tour ng & Music.

YET ANOTHER EVENT

108 "The Broadwaters"
TASCOT NSW 2250
PH: +61 2 4325 4867
FAX: +61 2 4325 4867
EMAIL: yaegirls@smartchat.net.au
KEY STAFF: Barbara Williams: Director, Anita Freed: Director
TABLE LIGHTING
The battery operated Deco Glass Ball Lights come in two sizes for formal dining or cabaret tables, for bars, on plinths or for anywhere that you need a warm practical glow of light.
They can be decorated to suit any theme, and can be used indoors and outdoors. No Cabling involved.

N.T. COMPLETE PRODUCTION COMPANY

Top End Sounds P/L

24 Stuart Highway
STUART PARK NT 0820
PH: +61 8 8981 7744
FAX: +61 8 8981 7525
EMAIL: tes@topendsounds.com.au
KEY STAFF: Colin West: Director, Kerrie Alterator: Sales/Administration, David Houghton: Production, Jeremy Wright: Hires/AV

QLD. COMPLETE PRODUCTION COMPANY

ALLSET PRODUCTIONS P/L

Gate 2, 167 Hyde Road
YERONGA QLD 4104
PH: +61 7 3892 6277
FAX: +61 7 3892 7309
EMAIL: mail@allset.com.au
WEB: www.allset.com.au
KEY STAFF: Wendy Brough: Managing Director, Wayne Appleton: Production Manager
Production Management
Set Design
Construction
Scenic-Art
Inflatables
Signs
Banners
Backdrops
Entertainment - Rigging and Installation for Local, National and International Events.
Call our hire Department for all your staging requirements:
Indoor and Outdoor stages
Catwalks
Sets
Curtains, CUCS and Dressing.

Audio & Visual Innovations

41 Brookes Street
BOWEN HILLS QLD 4006
PH: +61 7 3252 4022
FAX: +61 7 3257 4950
KEY STAFF: Steve Grimes: Operations Manager, Kerrod Heineger: Lighting Manager, Mel Jones: PA Manager.

Australian Concert Productions

222 Barry Parade
FORTITUDE VALLEY QLD 4006
PH: +61 7 3854 1512
FAX: +61 7 3854 1504
EMAIL: admin@acp.net.au
WEB: www.acp.net.au

N.S.W. N.T. QLD.

KEY STAFF: Mick Privitera: Managing Director, Rob Eastick: General Manager, Wayne King: Hire.

Ben Sorensen Enterprises

Lot 27 Watson Road
SAMSONVALE QLD 4520
PH: +61 7 3425 1373
FAX: +61 7 3261 8604
EMAIL: ben@bse.hypermart.com
WEB: www.bse.hypermart.com
KEY STAFF: Ben Sorensen: Proprieter.

Chatterbox Sound & Lighting

Glenview Road
UPPER COOMERA QLD 4209
PH: +61 7 5529 9969
FAX: +61 7 5529 9969
EMAIL: chatterboxes2000@hotmail.com
KEY STAFF: David Lee-Jay: Director, Sheila Lorraine: Director

Event Production Management (AUST) PTY LTD

Studio 1, 55 Winderadeen Drive
NERANG QLD 4211
PH: +61 7 5596 1966
FAX: +61 7 5527 3181
EMAIL: eventpro@primus.com.au
KEY STAFF: Leon Barreau: Managing Director, Sandra Barreau: Director of Marketing.

Gravity Electronic Productions

1/22 Tedder avenue
MAIN BEACH QLD 4217
PH: +61 7 5531 0681
FAX: +61 7 5561 1244

Kennedy Amplifier Hire Service

2 Kennedy Street
MACKAY QLD 4740
PH: +61 7 4957 3904
FAX: +61 7 4957 3805
EMAIL: kahs@mackay.net.au
KEY STAFF: Dale

IJS Concert Sound

66 Abotsford Road
BOWEN HILLS QLD 4006
PH: +61 7 3852 2646
FAX: +61 7 3854 1608
EMAIL: ijs@ats.com.au

WEB: <http://www.ijs.com.au>
KEY STAFF: Ivan Simon: General Manager, Eric Nisbett: Hire Manager.

JD SOUND

927 New Cleveland Road
GUMDALE QLD 4154
PH: +61 7 3245 3536
FAX: +61 7 3390 3128
EMAIL: jdsound@bit.net.au
KEY STAFF: John And Charlene Dunn
Professional Service In Mobile Stages, Stage Risers, Audio Production, Lighting, Generators, Change Rooms, etc.
Expert Friendly Advise In The staging Of Your Concert, Sports Carnival, Street Festival And Outside Broadcasts. No Event Too Big Or Small.

ODC Productions

Unit 1B/11 Moreton Bay Road
CAPALABA QLD 4157
PH: +61 7 3823 2179
FAX: +61 7 3823 2198
EMAIL: olaf@odcproductions.com.au
KEY STAFF: Olaf DeCeuster: Managing Director, Russell Coffey: Hire Manager.

Pure Magic Productions

388 Flinders parade
BRIGHTON QLD 4017
PH: +61 7 3269 4303
FAX: +61 7 3869 4339
EMAIL: puremagic@orangemail.com.au
KEY STAFF: Steve Hartley: Production Manager

SKYPAK LIGHTING & PRODUCTION SERVICES P/L

22 Maud street
NEWSTEAD QLD 4006
PH: +61 7 3852 2757
FAX: +61 7 3252 8910
KEY STAFF: Craig Fussell: Director/Operator, Brian story: Hire/Production
In Hire Martin Mac 500's, 600's, 250's, 1200's. Also Clay Paky, Martin, Gem, Mirrored Fixtures and Disco Effects.
Control Consoles, Martin Cases, HOG 1000, Event 408, 48/96, 24/48, Celco Navigators. Air Cooled Laser Systems, 1 Watt, 300 MLW and Water Cooled Lasers.

The Production Shop

82 Berwick Street
FORTITUDE VALLEY QLD 4006
PH: +61 7 3216 1340
FAX: +61 7 3216 1376
KEY STAFF: Graeme Hicks & Tim Kennard

TRANSTEC (Sound, Lighting, DJ's)

5/25 Upton Street
BUNDALL, GOLD COAST QLD 4217
PH: +61 7 5570 3345
FAX: +61 7 5870 3395
EMAIL: transtec@bigpond.com
KEY STAFF: Mark Stanford: Director, Aaron Watt: Sales, Lee Dunbar: Hire Department.

Wild Gravity Sarjack Pty Ltd

15 Wentworth Court
MARYBOROUGH QLD 4650
PH: +61 7 4121 6189
FAX: +61 7 4121 6189
EMAIL: selconell@aia.net.au
KEY STAFF: Selwyn Connell: proprieter/Sound/A.V., Sue Hart: Lighting Designer/Operator, Blair Fraser: Camera/Editor

Wild Gravity Sarjack Pty Ltd

106 Boundary Street
RAILWAY ESTATE
PH: +61 7 4721 3540
FAX: +61 7 4721 1375
EMAIL: wildgrav@ozemail.com.au
WEB: wildgravity.com.au

QLD.

LIGHTING

A Action Packed Lightshows

Shop 1, 119 Oxley road
CHELMER QLD 4068
PH: +61 7 3379 4313
FAX: +61 7 3379 4049
WEB: www.actionpacked.com.au

Abstract Lighting

5 Pidgeon Drive
DECEPTION BAY QLD 4508
PH: +61 7 3888 0222
FAX: +61 7 3888 5967
EMAIL: phillip_kay@bigpond.com

Entertainment Lighting & Sound

30 Taree Street
BURLEIGH JUNCTION QLD 4220
PH: +61 7 5593 5105
FAX: +61 7 5593 5161
EMAIL: els@onthenet.com.au
KEY STAFF: Phil stafford: Managing Director, Greg Horrocks: Sales Manager, Di Ritchie: Administration Manager.

Fifalite Effects Lighting

Unit 4/7 Charlston Place
MAROOCHYDORE QLD 4558
PH: +61 7 5479 5474
FAX: +61 7 5479 5475
KEY STAFF: David Pfeiffer: Managing Director, Pat Base: Engineer.

Jim Philip Fairylights

420 Moggill Road

INDCOROOPILLY QLD 4068
PH: +61 7 3878 3896
FAX: +61 7 3379 4313
WEB: www.actionpacked.com.au

Multi Image Lighting

Suite 3/ 10lympic Circuit
SOUTHPORT QLD 4215
PH: +61 7 5528 1253
FAX: +61 7 5528 1256
KEY STAFF: Chris King: General Manager, Stewart Wall: Hire Services

Premier Lighting

32 Chester Street
FORTITUDE VALLEY QLD 4006
PH: +61 7 3257 0443
FAX: +61 7 3257 0451
EMAIL: craig@premierlighting.com.au
KEY STAFF: Craig Ryder: Manager, David Nemett: Hire Manager.

QLD.

AUDIO

Acoustic Technologies

8 - 10 Staple Street
17 MILE ROCKS QLD 4073
PH: +61 7 3376 4122
FAX: +61 7 3376 5793
EMAIL: info@acoustic-tech.com.au
WEB: www.acoustic-tech.com.au
KEY STAFF: Ean Redman: Hire Manager

Brisbane Sound Hire

36 Agnes Street
FORTITUDE VALLEY QLD 4006
PH: +61 7 3252 4935
FAX: +61 7 3252 7874
EMAIL: hire@brisound.com.au
WEB: www.brisound.com.au
KEY STAFF: Alf Velm: Hire Manager, Patrick Zietch: Hire Technician, John Wallace: Hire Technician.

CPC Audio PTY LTD

14 Short Street
BUNDAMBA QLD 4304
PH: +61 7 3816 1009
FAX: +61 7 3816 1791
EMAIL: cpcaudio@power.com.au
KEY STAFF: Mr Murray Keidge: Director, Mr Eric Taylor: General Manager, Mr Steve Alexander: SNR Audio Engineer.

Image Audio Productions PTY LTD

PO Box 289
BROWNS PLAINS QLD 4118
PH: +61 7 3800 7742
FAX: +61 2 3800 1847
EMAIL: iap@powerup.com.au
WEB: www.imageaudio.com.au
KEY STAFF: Benjamin Page: Managing Director



82 Berwick St, Fortitude Valley QLD 4006
Ph: (07) 3216 1340 Fax: (07) 3216 1376
Email: graeme@productionshop.com.au
Web: www.productionshop.com.au

ALL YOUR
PRODUCTION NEEDS
AT THE ONE PLACE!

JD SOUND

927 New Cleveland Road
GUMDALE QLD 4154
PH: +61 7 3245 3536
FAX: +61 7 3390 3128
EMAIL: jdsound@bit.net.au
KEY STAFF: John And Charlene
Dunn

Professional Service in Audio
production, Mobile Staging &
Broadcast Services. QLD's largest
Provider Of Line Distributed
Systems For Sport, Air Shows,
And Festivals. Inventory includes
JBL Arrays, Ramsa A200s & 300s,
100's Of Inkel Columns & Toa
Horns, Austalian Monitor, Crest &
Ramsa Amps. You need To Be
Heard, We'll Get Your Message
Across.

Paradise Music Factory

Factory 1, Ern Harley Drive
BURLEIGH HEADS QLD 4220
PH: +61 7 5575 1990
FAX: +61 7 5575 2740
EMAIL: paradise@fan.net.au
KEY STAFF: Barry williams: Owner,
Anne Williams: Owner

PARAMOUNT AUDIO SYSTEMS & COVERS

34 Torellianas Drive
STRATHPINE QLD 4500
PH: +61 7 3205 7151
FAX: +61 7 3205 7151
EMAIL: gregf@powerup.com.au
WEB: www.powerup.com.au/~gregf
KEY STAFF: Greg French: Owner/
Director, Grant Henderson
Established in 1987. Audio Hire,
Sales and Installations. Small
Vocal to Large P.A's. Driveway Hire
or Professional Crews. Club,
Corporate or Outdoors. Equipment
includes Australian Monitor, RCF,
Allen and Heath, Yamaha,
Behringer, Shure, Beyer, etc.
We also make canvas speaker and
Amp Covers. Supplying to hire
companies and shops in QLD and
throughout Australia.

Show Biz Sound

66 Kitchener Street
SHERWOOD BRISBANE QLD 4075
PH: +61 7 3379 7900
FAX: +61 7 3379 7900
KEY STAFF: Richard Autenzio: Owner

QLD.

AV/STAGING

ALLSET PRODUCTIONS P/L

Gate 2, 167 Hyde Road
YERONGA QLD 4104
PH: +61 7 3892 6277
FAX: +61 7 3892 7309
EMAIL: mail@allset.com.au
WEB: www.allset.com.au
KEY STAFF: Wendy Brough:
Managing Director, Wayne
Appleton: Production Manager
Production Management
Set Design
Construction
Scenic-Art
Inflatables
Signs
Banners
Backdrops
Entertainment – Rigging and
Installation for Local, National and
International Events.
Call our hire department for all
your staging requirements: Indoor
and Outdoor stages
Catwalks
Sets
Curtains, CUCS and Dressing.



GEARHOUSE BRISBANE

31 Wellington Road
EAST BRISBANE QLD 4169
PH: +61 7 3392 2777
FAX: +61 7 3392 2477
EMAIL: brisbane@gearhouse.com.au
WEB: www.gearhouse.com
KEY STAFF: Jenny Dobie:
Manager, Lyn Brain: Operations.
As the world's leading provider of
presentation and staging services
the Gearhouse Group consists of
specialist divisions focused on
your event success. Corporate
Presentations, Themeing, and set
building specialist lighting and
sound, Exhibitions, Equipment
sales, design and installation,
concert video and lighting
combine to ensure that Gearhouse
has the right solution for you.



HAYCOM STAGING

Unit 1/12 Walker Street
WOOLLOONGABBA QLD 4102
PH: +61 7 3392 2644
FAX: +61 7 3392 2655
EMAIL:
info.bris@haycomstaging.com.au
WEB: www.haycomstaging.com.au
KEY STAFF: Mr Lester (Doc)
Jurrott: General Manager, Ms
Tamara Edwards: Account
Executive, Mr Scott Bennett:
Senior Technical Director.
Established in 1973, Haycom
Staging has grown to become the
largest independently owned
audiovisual staging company in
Australia, having consolidated a
reputation for superior service and
expertise in the area of large
screen projection and corporate
theatre.
We can supply Technical
Directors, show crew and all
equipment, including the famous
Hughes cinema quality projectors.
Offices in Sydney, Melbourne,
Brisbane, Adelaide and Perth.

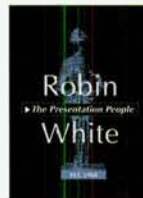

ROBIN WHITE – THE PRESENTATION PEOPLE

78 Berwick Street
PO Box 304
FORTITUDE VALLEY QLD 4006
PH: +61 7 3252 0000
FAX: +61 7 3252 0222
WEB: www.robinwhite.com.au
KEY STAFF: Jennifer Rylance:
Managing Director/Owner, Tim
Rylance: Owner, Anthony Cullen:
Operations Manager.
The Largest Independent AV hire/
staging company based in central
Brisbane, is happy to look after
your clients AV needs in QLD.
The only company to offer 72" &
68" SXGA/video retro cabinets,
remote control projection screens,
graphic switcher, Plasma screens,
Huge range of LCD projectors,
audio, etc. Full range of exhibition,
conference equipment & operators.
Robin White offers QLD's only AV
Training Course – Introduction to
AV & Customer Service Certifi-
cate. (Available To Venue, Industry
Staff & The Public.)



RYLANCE WHOLESALE RENTALS

78 Berwick Street
PO Box 304
FORTITUDE VALLEY QLD 4006
PH: +61 7 3252 0111
FAX: +61 7 3252 0222
EMAIL: tim@rylance.com.au
Emailto: info@robinwhite.com.au
WEB: www.robinwhite.com.au
KEY STAFF: Jennifer Rylance:
Owner, Tim Rylance: Owner,
Anthony Cullen: Operations
Manager.
Australia's only wholesale AV
equipment hire company.
Large range Of LCD projectors &
ceiling mounts, scan converters,
vision mixers (including
Anologway graphic switcher –
allows any data or video input to
screen at selected resolution),
Plasma Screens, audio, etc at
greatly reduced prices. Service is
available exclusively to AV hire,
staging industry and production
company's. They must be able to
demonstrate technical expertise to
operate & care for all equipment
to qualify for special trading
conditions.

Staging Connections Brisbane

6 Sneyd Street
BOWEN HILLS QLD 4006
PH: +61 7 3252 9333
FAX: +61 7 3252 4674
EMAIL:
ggay@stagingconnections.com.au
WEB: www.stagingconnections.com.au
KEY STAFF: Geoff Gay

Staging Connections Gold Coast

19 Northview Street
MERMAID BEACH QLD 4218
PH: +61 7 5526 0500
FAX: +61 7 5572 3355
EMAIL:
rschuhle@stagingconnections.com.au
WEB: www.stagingconnections.com.au
KEY STAFF: Reiner Schuhle

Staging Connections Whitsundays

Convention Centre
HAMILTON ISLAND QLD 4803
PH: +61 7 4948 9077
FAX: +61 7 4948 9076
EMAIL:
pdelangen@stagingconnections.com.au
WEB: www.stagingconnections.com.au
KEY STAFF: Phillip Delangen

Take control of a major

Apple introduces Desktop Movies.

Combine the Power Mac™ G4 with

Final Cut Pro™ software and you have



Built-in FireWire lets you import video directly from a digital camcorder with zero loss of quality.

the first pro-quality desktop movie studio for under \$10,000*.

Never before has so

much digital-video firepower been

built into such a small space – with

everything you need to create and

edit Desktop Movies, develop rich

multimedia websites, even host a

site serving thousands of concurrent

video streams. At the heart of this

hard-working movie studio is the G4 processor with Velocity Engine™ – a 128-bit

supercomputer on a chip that can perform compute-intensive tasks (like rendering

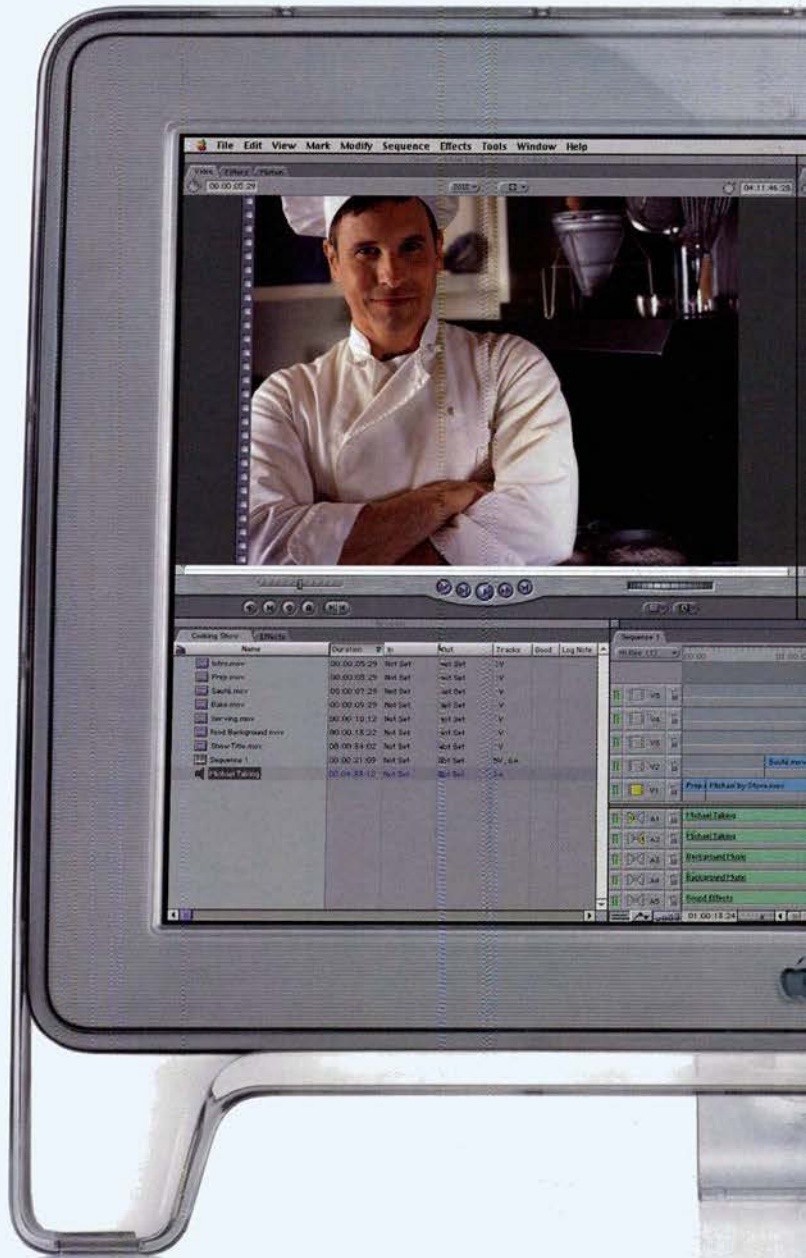

motion picture studio.

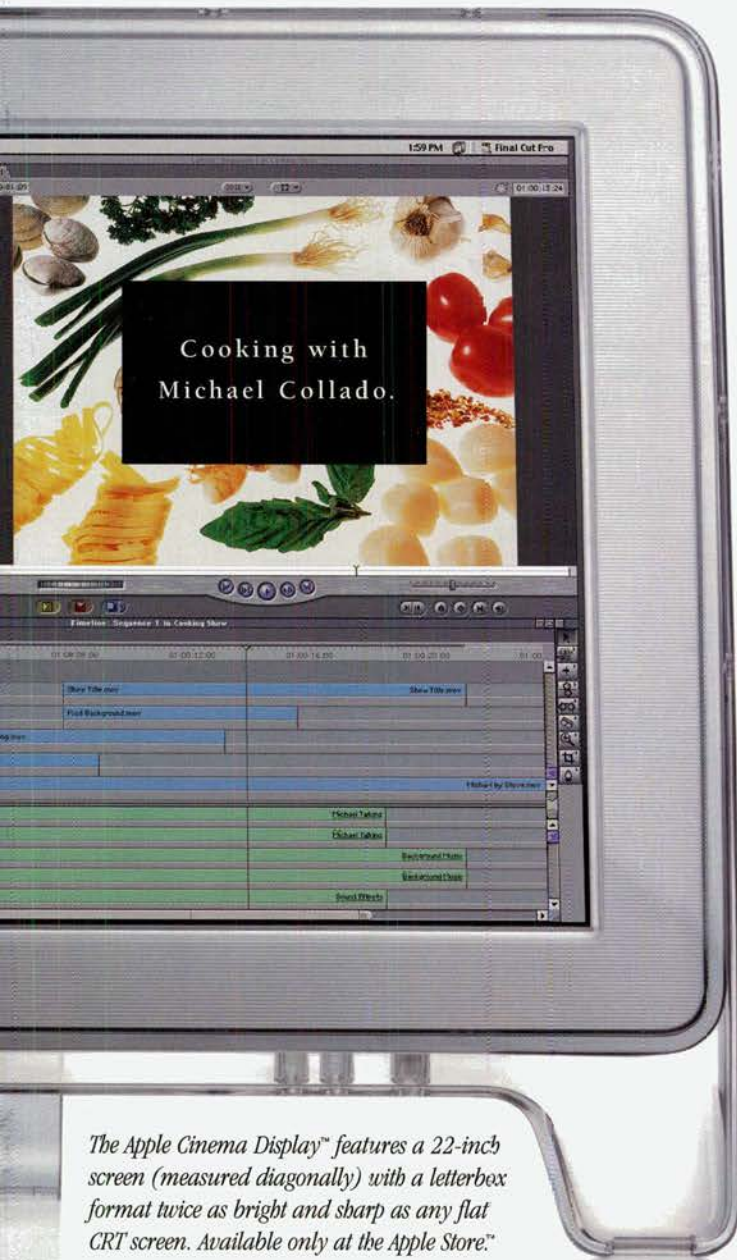

The Apple Cinema Display™ features a 22-inch screen (measured diagonally) with a letterbox format twice as bright and sharp as any flat CRT screen. Available only at the Apple Store.™

disk. So if you want to make it big in movies, forget the power suit. And go for the Power Mac. For complete details, visit www.apple.com.au

digital video effects) up to twice as fast as the 733MHz Pentium III.† In fact, every part of the Power Mac G4 is built for Desktop Movies.

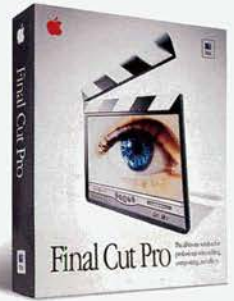

Optional Final Cut Pro software has the features of a high-end edit bay, with built-in effects, at a fraction of the cost.

It has built-in FireWire®, so you can connect a digital camcorder and import video with superior digital quality. It has superfast memory (expandable up to 1.5GB) and hard disk (up to 27GB), with room for three internal drives. And it offers DVD-RAM, so you can archive up to 6GB on a single



Think different.™

VGAV PTY LTD

1/101 Newmarket Road
WINDSOR QLD 4030
PH: 0500 501 300
FAX: 0500 501 301
EMAIL: chris@vgav.com.au
WEB: www.vgav.com.au
KEY STAFF: Christopher Greenets:
Director
Australian distributor for
Communications Specialties
products, including Scan Do
Select, Pro and Ultra Computer to
video converters, Deuce and
Deuce Pro Video Scalers/line
Quadruplers, and Math Fibre
Optics transmission systems for
point to point connection of Video,
Audio and Data.

QLD.

OTHER

ICR Computer Rentals Pty Ltd

3/104 Breakfast Creek Road
NEWSTEAD QLD 4005
PH: +61 7 3257 3566
FAX: +61 7 3257 3599
EMAIL: icr@bigpond.com.au
WEB: www.icr-rentals.com.au
KEY STAFF: Jana Harewood: QLD
Sales Manager, Mark Greenway:
Sales and Technical Rep.

LANCASTER PRODUCTIONS

7/7 Villiers Drive
Currumbin QLD 4223
PH: +61 7 5598 7199
FAX: +61 7 5598 7311
EMAIL: mail@lancasters.com.au
WEB: www.lancasters.com.au
KEY STAFF: Chris Lancaster:
Managing and Creative Director,
Jaquie Lancaster: Entertainment
Director, Brooke Ingram: Office
Manager, Rachel Gay: Accounts.
Lancaster Productions is a staging,
themeing & special events
production company incorporating
a full service entertainment
agency. We offer exciting theme
packages, tailored to your
individual requirements, or can
create unique and exciting new
concepts.
We have a comprehensive range
of theme props, backdrops,
drapes, stage dressings, lighting,
staff costumes, table linen and
unique table centrepieces.

S.A.

COMPLETE
PRODUCTION
COMPANY

BBS Light & Sound

334 Port Road
HINDMARSH SA 5007
PH: +61 8 8340 3100
FAX: +61 8 1340 4177
EMAIL: sales@bbslightandsound.com.au
WEB: www.bbslightandsound.com.au
KEY STAFF: Mathew Dixon: Sales
Manager, Russel Alexander: Hire
Manager.

GOLIGHT

34 The Parade west
KENT TOWN SA 5067
PH: +61 8 8363 3393
FAX: +61 8 8363 3392
EMAIL: tim_marshall@golight.com.au
WEB: www.golight.com.au
KEY STAFF: Tim Marshman:
Manager, Justin Wagener: Factory
Technician
Sound & Lighting, site electrical
services, crew, transport, staging,
crowd barriers.
Concert, Corporate, Theatre, Schools,
Churches, Broadcast, Complete
production service to dry Hire.
EAW Speaker Systems, MIDAS
desks, UHF radio microphones,
110V power, Design and
manufacturer of compact speaker
systems. Hire, sales, installation &
service of a wide range of
professional equipment.

Osmond Electronics

142-150 Gray Street
ADELAIDE SA 5000
PH: +61 8 8410 1111
FAX: +61 8 8410 1111
EMAIL:
info@osmondelectronics.com.au
WEB: www.osmondelectronics.com.au
KEY STAFF: george Psorakis:
Managing Director, John Murdoch:
manager, Darren Boughton: Production
Manager.

Pro Co Stage Sound Whyalla

1/77 Essington Lewis Avenue
WHYALLA SA 5600
PH: +61 8 8644 0211
FAX: +61 8 8644 0233
EMAIL: proco@wh.camtech.net.au
KEY STAFF: Ron Hay: Proprietor, Irene
Palmer: Office Manager.

Sensitive Grunt Productions

PO Box 1038
MOUNT BARKER SA 5251
PH: +61 8 8391 3233
FAX: +61 8 8391 3233
EMAIL: prlx@alis.net.au
KEY STAFF: Peter Robins: Manager

S.A.

LIGHTING

GOLIGHT

34 The Parade west
KENT TOWN SA 5067
PH: +61 8 8363 3393
FAX: +61 8 8363 3392
EMAIL:
tim_marshall@golight.com.au
WEB: www.golight.com.au
KEY STAFF: Tim Marshman:
Manager, Justin Wagener: Factory
Technician
Sound & Lighting, site electrical
services, crew, transport, staging,
crowd barriers.
Concert, Corporate, Theatre,
Schools, Churches, Broadcast,
Complete production service to dry
Hire.
EAW Speaker Systems, MIDAS
desks, UHF radio microphones,
110V power, Design and
manufacturer of compact speaker
systems. Hire, sales, installation &
service of a wide range of
professional equipment.

Psycholites

43 Kind Street
NORWOOD SOUTH AUSTRALIA 5067
PH: +61 8 8267 3719
FAX: +61 8 8239 0280
WEB: plights.com.au
KEY STAFF: Ian Linton: Manager, Sue
Linton: Secretary.

Totally
Active
Solutions
Pty.Ltd.

EVENT MANAGEMENT,
COORDINATION AND LOGISTICS
CORPORATE, CONFERENCE AND
EVENTS SPECIALISTS

1-7 Queens Avenue Hawthorn, Vic. 3122, Australia Tel: (613) 9819 6912 Fax: (613) 9819 6008 Email: tas1@activelighting.com.au

S.A.**AUDIO****Adelaide Sound Hire**

13 Martindale Avenue
TOORAK GARDENS SA 5065
PH: +61 8 8331 9605
FAX: +61 8 8331 9605
EMAIL: adlsound@camtech.net.au
KEY STAFF: Peter Morris: Manager,
Peter Lambe: Engineer

GOLIGHT

34 The Parade west
KENT TOWN SA 5067
PH: +61 8 8363 3393
FAX: +61 8 8363 3392
EMAIL:
tim_marshall@golight.com.au
WEB: www.golight.com.au
KEY STAFF: Tim Marshman:
Manager, Justin Wagener: Factory
Technician
Sound & Lighting, site electrical
services, crew, transport, staging,
crowd barriers.
Concert, Corporate, Theatre,
Schools, Churches, Broadcast,
Complete production service to dry
Hire.
EAW Speaker Systems, MIDAS
desks, UHF radio microphones,
110V power, Design and
manufacturer of compact speaker
systems. Hire, sales, installation &
service of a wide range of
professional equipment.

S.A.**AV/STAGING****CLIPSAL VISION
SUPER SCREEN****Clipsal Vision Super Screens PTY
LTD**

40 Bi ralee Road
REGENCY PARK SA 5010
PH: +31 8 8445 9600
FAX: +61 8 8268 6755
EMAIL: superscreen@clipsal.com.au
WEB: www.clipsalvision.com.au
KEY STAFF: Angelo Russo: Sales &
Marketing, Cam Johnson: Operations,
Geoff Ellery: Managing Director.

Staging Connections Adelaide

59 King William street
KENT TOWN SA 5067
PH: +61 8 8363 1006
FAX: +61 8 8363 1402
EMAIL:
dbiar@stagingconnections.com.au
WEB: www.stagingconnections.com.au
KEY STAFF: Dave Biar

S.A.**OTHER****INDOOR PYROTECHNICS**

PO Box 16
PROSPECT SA 5082
PH: +61 8 (0)419 816 461
FAX: +61 8 8344 9917
EMAIL: indoorpyro@bigpond.com
WEB: www.indorpyro.com.au
KEY STAFF: Nick Papamichael:
Manager/Pyrotechnician, Paul
Pyatt: Manager/Systems Designer,
Michelle Papamichael: Office
Accounts.
Indoor Pyrotechnics are leading
providers of close proximity
pyrotechnics creating stunning
professional indoor displays.
We can also mesmerize you with
amazing outdoor fireworks
displays.
Colours that will amaze and
effects that will leave a lasting
impression enhancing the ooh &
aah level with your audience.
Want to know more please
browse our web site.

PRODUCTION WORKS

74-80 Malle Street
HOBART TAS 7000
PH: +61 3 6231 1505
FAX: +61 3 6231 1504
EMAIL:
productionworks@trump.net.au
WEB: www.productionworks.com.au
KEY STAFF: Tony Miller: General
Manager, Doug Edwards:
Production Manager, Stevan
Bocojevic: Production Manager.
EVI, X-Array, Midas, Klark, Teknik,
Avolites, Rigging, Sound, Lights,
AV/Staging, Backline, Crewing We
can do a complete package. We
are available for national tours
from Rock to opera call for a
brochure or quote.
After Hours: 0418 122 188 (Tony
Miller)

TAS.**LIGHTING****Extreme Lighting
Multi Image Lighting**

89 Mercey Main Road
SPREYTON TAS 7310
PH: +61 3 6427 29 19
FAX: +61 3 6427 0696
KEY STAFF: Michael Westcott:
Manager

TAS.**COMPLETE
PRODUCTION
COMPANY****Powersound**

4 Durham Road
COOEE BURNIE TAS 7320
PH: +61 3 6431 7722
FAX: +61 3 6431 7722
EMAIL:
powersoundburnie@bigpond.com
WEB: www.users.bigpond.com/
powersoundburnie.htm
KEY STAFF: Neville Fisher: Manager,
Ben Turnbull: Audio Engineer

TAS.**AUDIO****Soundfix Audio Production**

103 Reibey Street
ULVERSTONE TAS 7315
MOB: +61 (0)418 317 758
FAX: +61 3 6425 5989

Oceanic
Professional Audio Equipment
Theatre Services & Design

MELBOURNE, AUSTRALIA
PH: +61 3 9362 0499
FAX +61 3 9362 0699

AUCKLAND, NEW ZEALAND
PH: +64 9 849 3114
FAX +64 9 849 3307

S.A. TAS.

KEY STAFF: Greg Dunham: Owner/
Operator, Jarrod Bishop: Audio, Troy
McCarthy: Lighting.

PH: +61 3 9531 1403
FAX: +61 3 9531 2688
EMAIL: mark@bssound.com.au
WEB: www.bssound.com.au
KEY STAFF: Mark Barry: Manager/
Sound Engineer

Low Cost Sound Productions
73 Wenhams Lane
WANGARATTA VIC 3677
PH: +61 3 5721 3951
MOB: +61 (0)408 44 8366
KEY STAFF: Chris Ker: Manager,
Daniel O'Connell: Sound Engineer

**Sunrise Stage & Screen
Production Services (Chelsea)**
PO Box 9110
SEAFORD MDC VIC 3198
PH: +61 3 9774 2485
FAX: +61 3 9774 2766
PAGER: 24 Hour +61 3 9625 3349
MOBILE: 0409 178 302

TAS.

AV/STAGING

Staging Connections Hobart

1/16 Mertonvale Circuit
KINGSTON TAS 7050
PH: +61 3 6229 7510
FAX: +61 3 6229 7530
EMAIL:
tbanfield@stagingconnections.com.au
WEB: www.stagingconnections.com.au
KEY STAFF: Tim Banfield

Christopher Ballis Events

Coordination
Unit 2/5 Rill Street
HEIDELBERG VIC 3187
PH: +61 3 9457 4061
EMAIL: stitskin@netspace.net.au
KEY STAFF: Christopher Ballis:
Manager

Moon Mother Productions

PO Box 6196
MELBOURNE VIC 8008
PH: +61 (0)419 388 646
FAX: +61 3 9696 1125
EMAIL: moon@surfnetcity.com.au
KEY STAFF: Jenny Davidson: Director,
David Wignall: Production Manager.

Nova Hire PTY LTD

38 Isabella Street
MOORABBIN VIC 3189
PH: +61 3 9555 4766
FAX: +61 3 9553 2381
EMAIL: novahire@metrosystems.com.au
KEY STAFF: Peter McCarthy: Manager,
Ishan Cooper: Hire Department, Jamie
Evans: Production Department.

Premier Production Services

433 Graham Street
PORT MELBOURNE VIC 3207
PH: +61 3 9646 4522
FAX: +61 3 9646 5020
EMAIL: premier@premierlighting.com.au
KEY STAFF: Shane Jacobson: General
Manager, Andrew Holmes: Director,
Bob Prosser: Director.

SLC Sound & Lighting Concepts

26 Martin Drive
DELACOMBE VIC 3356
PH: +61 3 5336 1255
FAX: +61 3 5336 1320
EMAIL: slc@slc.au.com
WEB: www.slc.au.com
KEY STAFF: Craig Butterworth:
Partner/Manager, Geoffrey Johnston:
Partner, Mathew Oates.



Clifton Productions

53-55 Sparks Avenue
FAIRFIELD VIC 3078
PH: +61 3 9486 8080
FAX: +61 3 9489 5215
EMAIL:
warren@cliftonproductions.com.au
KEY STAFF: Warren Maher: manager,
Murray Hare: Production Manager

DB Concert Sound

26 Riversdale Road
GEELONG VIC 3220
PH: +61 3 5221 1688
FAX: +61 3 5221 4113
EMAIL: ddbc@pipeline.com.au
WEB: www.dbcon.com.au
KEY STAFF: Bill Dart: Managing
Director, Bill Busbridge: Production
Manager, Allan Kelly: Service
Manager.

Disco World P/L

Factory 20 Cave Hill Road
LILYDALE VIC 3140
PH: +61 3 9735 0588
FAX: +61 3 9739 5441
EMAIL: info@discoworld.com.au
WEB: www.discoworld.com.au

VIC.

**COMPLETE
PRODUCTION
COMPANY**

Advanced Audio PTY LTD

6 York Street
RICHMOND VIC 3121
PH: +61 3 9416 1433
FAX: +61 3 9419 4773
EMAIL: advanced.audio@nemesis.com.au
KEY STAFF: Steve Kirtland: Hire
Manager/GM, Richard Hallam: Sales/
Installation, Graham Rankin: Hire
Bookings.

Bishop Audio & Lighting P/L

22 Dowsett Street
GEELONG VIC 3200
PH: +61 3 5229 2269
FAX: +61 3 5229 0776
WEB: www.bishopaudio.com.au
KEY STAFF: Kevin Bishop: Managing
Director

B.S Sound PA Hire

64 Spray Street
ELWOOD VIC 3184



**TOTALLY ACTIVE
SOLUTIONS PTY LTD**

1-7 Queens Avenue
HAWTHORN VIC 3122
PH: +61 3 9819 3516
FAX: +61 3 9819 6008
KEY STAFF: Barry Kerr: Manager,
David Wright: Production
Manager, Darren: Production.
Active Lighting now offers a
complete production service able
to totally manage and co-ordinate
your event, whatever your needs.
Innovative themes and production
designs; Solutions for all
corporate functions and confer-
ences. We can organise lighting,
audio, staging and professional
experienced staff who are
available for design, consultation,
site inspections, production
management and installation.

TAS. VIC.

big beat productions pty ltd



Professional Audio Rental and Installation
Production for Concerts, Theatre, Schools and Corporate
Audio design service for unusual applications
Complete Production Solutions

9-13 Stawell St., North Melbourne VIC 3051 • Tel: 61 3 9329 3311 Fax: 61 3 9329 4344 • Big Beat Productions P/L T/as Johnston Audio Services

VIC.

LIGHTING



ACTIVE LIGHTING PTY LTD

1-7 Queens Avenue
HAWTHORN VIC 3122
PH: +61 3 9819 6912
FAX: +61 3 9819 6008
EMAIL:
activeelt@activelighting.com.au
KEY STAFF: Sean Scully: Hire
Manager, Barry Kerr: Manager,
David Wright: Production Manager.
Active Lighting offers all
customers the same high standard
of service in lighting hire and
production, all supported by 24
hour back up service. Whether you
are in charge of touring produc-
tions, school productions or
corporate conventions, Active
Lighting will provide the highest
level of service possible. Active
Lighting stocks a comprehensive
range of theatrical and automated
luminaires, lighting consoles and
dimmers.

**BROWN'S PRECISION
WELDING**

56 Mologa Road
WEST HEIDELBERG VIC 3081
PH: +61 3 9455 2899
FAX: +61 3 9457 5044
MOBILE: 0412 401 469
KEY STAFF: Peter Brown:
Managing Director, Gerard Cook:
Manufacturing, Vicki Burke:
Accounts.
Specializing in all the latest
aluminum triangular and box Truss
systems. Supplier's to lighting,
sound and audio visual company's
as well as convention and
entertainment venues in Australia.
High quality and competitive
prices guaranteed.



**BYTECRAFT®
BYTECRAFT THEATRICAL
PTY LTD**

23-31 Fonceca Street
MORDIALLOC VIC 3195
PH: +61 3 9587 2555
FAX: +61 3 9587 5641
EMAIL: bytecraft@bytecraft.com.au
WEB: www.bytecraft.com.au
KEY STAFF: Durham Ritchie:
National Sales Manager, Jay
Davis: Hire Manager.
Professional range of Theatre,
Film/TV and Concert Lighting
Equipment, including lanterns,
control desks, dimmers, pre-rig
truss, ICON and High End Moving
Lights, Skytracker searchlights,
Pani projectors, rigging and
motors and the latest safety gear.
Full lighting production services
are available from design to bump
out including crew and operators.

CC's Light And Sound

17 Alex Avenue
MOORABBIN VIC 3189
PH: +61 3 9532 0488
FAX: +61 3 9553 2798
EMAIL: hire@ccsightsound.com.au
WEB: www.ccsightsound.com.au
KEY STAFF: Roger Clapton: Director



Clearlight Shows Pty Ltd

Clearlight Shows PTY LTD
9 Horscroft Place
MOORABBIN VIC 3189
PH: +61 3 9553 1688
FAX: +61 3 9553 4401
EMAIL: clearlight@clearlight.com.au
WEB: www.clearlight.com.au
KEY STAFF: John McKissock:
Managing Director, Martin Bowman:
Hire Department Manager, Lachlan
Sinclair: Production Manager.



Clifton Productions

53-55 Sparks Avenue
FAIRFIELD VIC 3078
PH: +61 3 9486 8080
FAX: +61 3 9489 5215
EMAIL: warren@cliftonproductions.com.au
KEY STAFF: Warren Maher: manager,
Murray Hare: Production Manager

**Concert Lighting Systems
Australia P/L**

63-65 Kingsway
SOUTHBANK VIC 3006
PH: +61 3 9682 6111
FAX: +61 3 9682 6777
EMAIL: info@clsa.com.au
WEB: www.clsa.com.au
KEY STAFF: Anna Angelico-Bakker:



BYTECRAFT®

BYTECRAFT®

Design and Manufacture of High Quality Entertainment
Lighting Systems and Stage Automation Systems



BYTECRAFT®

HIRE

- Stage, TV & Location Lighting
- Lighting Control Equipment
- Automated Lanterns
- Pani Projectors
- Searchlights
- Dimmers



SALES

Bytecraft Range of
Stage Automation Systems
Broadcast Quality Dimmers
Architectural Lighting Control Systems
Stage, TV & Location & Entertainment Lighting

SERVICE

- Lighting Equipment Service & Repair
- Strand & Quartzcolor Spare Parts
- Preventative Maintenance
- Colour & Correction Filters
- Gaffer Tape
- Lamps

EXCLUSIVE AUSTRALIAN DISTRIBUTOR



VIC - 23-31 Fonceca St, Mordialloc, 3195
Phone: (03) 9587 2555 Fax: (03) 9580 7690

Website: <http://www.bytecraft.com.au>
Email: bytecraft@bytecraft.com.au

NSW - 5/31 Bridge Rd, Stanmore, 2048
Phone: (02) 9550 3955 Fax: (02) 9519 3977

Business Manager, Leigh Greig;
Production Manager, John Andrews;
Hire Manager.

Keylighting Australia P/L

77 Moreland Street
FOOTSCRAY VIC3011
PH: +61 7 9687 0244
FAX: +61 3 9687 7866
EMAIL: keylight@eisa.net.au
KEY STAFF: Terry Riley: Manager,
Michael So: Electrician.

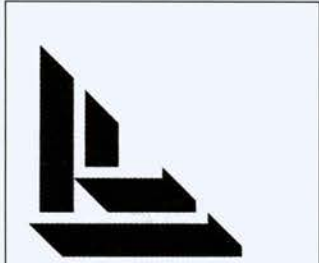

LIGHTING LAB

16 Clarice Road
BOX HILL VIC 3128
PH: +61 3 9898 7064
FAX: +61 3 9899 5774
WEB: www.lightinglab.com.au
KEY STAFF: Ray Vickery: Manager,
Gary Davey: Hire Manager.
Long & short term hire of lighting
systems or components. We can
supply all your lighting needs from
standard lights, effects, control
systems, rigging & stage risers, to
the latest in automated lights.
Lighting Lab really do hire the best
lights for less.

Premier Lighting Services

433 Graham Street
PORT MELBOURNE VIC 3207
PH: +61 3 9646 4522
FAX: +61 3 9646 5020
EMAIL: premier@premierlighting.com.au
KEY STAFF: Shane Jacobson: General
Manager, Andrew Holmes: Director,
Bob Prosser: Director.

SGM AUSTRALIA

PO Box 394
CHELSEA VIC 3196
PH: +61 3 9776 2555
FAX: +61 3 9776 2444
EMAIL: info@sgm.it
WEB: http://www.sgm.it
KEY STAFF: Mark: Director/
Technician, John: Technician/
Sales, Danielle: Admin/Sales.
Sales and hire of high Tec lighting
like the following;
Moving heads, scanners,
followspots, colourchangers,
lighting consoles, dimmers,
strobeflights, smoke machines,
also accessories, gobos,
barndoors, light domes, clamps,
safety chains, also dance floors
modules in five different patterns.
Call for prices and more
information. Our office is in
Chelsea, VIC or Email us on the
email address above or look at our
website.

STAGE TWO LIGHTING

51 Glen Eira Road
ST KILDA EAST VIC 3183
PH: +61 3 9528 2917
FAX: +61 3 9532 8430
KEY STAFF: Terry Haigney:
Production Manager, Ray Haigney:
Hire Manager
Specialising in hire and set-up of
portable modular stages. Hire and
sales of entertainment lighting.
Stockist of Nashua gaffer tape,
Lee filters And Gobo's, replace-
ment lamps and smoke fluid.
For friendly reliable service and
advice for theatrical and school
productions, outdoor festivals,
fashion shows and corporate
events please give us a call.

VIC.

AUDIO

Audio Live

28 Brougham Street
GEELONG VIC 3220
PH: +61 3 5224 2227
FAX: +61 3 5224 2236
KEY STAFF: Glen Hirst: Managing
Director, John Quick: Managing
Director, Paul Allen: Operations
Manager.

BIG BEAT PRODUCTIONS T/A JOHNSTON AUDIO SERVICES

9-13 Stawell Street
NORTH MELBOURNE VIC 3051
PH: +61 3 9329 3311
FAX: +61 3 9329 4344
EMAIL:
jas@johnstonaudioservices.com
WEB:
www.johnstonaudioservices.com
KEY STAFF: Bruce Johnston:
Director/Sound Design, Jamie
Ellis: Production Manager, David
Allpress: Production Manager,
Paul Gould: Hire manager.
Tour Package Specialists
Meyer Concert systems
EV X-Array Concert Systems
'Wayloud' Monitor Systems
JBL Systems
Midas & Yamaha Consoles
Lighting Systems
Sales
Transport
Staging
Backline
Permanent Installation Specialists
Production Management
Crewing

Durham Audio Visual Hire

65 Haig street
SOUTHBANK VIC 3006
PH: +61 3 9690 2288
FAX: +61 3 9696 4251
EMAIL: hire@durhamav.com.au
WEB: www.durhamav.com.au
KEY STAFF: Gary Ashmore: General
Manager, John Garfy: Account
Manager

McLean Audio services PTY LTD

Building 4-64 Balmain Street
RICHMOND VIC 3121
PH: +61 3 9429 5381
FAX: +61 3 9428 0156
EMAIL:
mclean@preston.starway.net.au
KEY STAFF: Richard Bilinski:
Managing Director, Michael Wickou:
Production Manager, Peter Shawcraft:
Equipment Manager.



Oceania Audio PTY LTD

Unit 1 & 2, 5-9 Hall Street
YARRAVILLE VIC 3013
PH: +61 3 9362 0499
FAX: +61 3 9362 0699
EMAIL:
robbaumanis@compuserve.com
KEY STAFF: Rob Baumanis: General
Manager, Simon Venning: Sound
Designer.



outlook
COMMUNICATIONS

OUTLOOK COMMUNICATIONS PTY LTD

121 Rupert Street
COLLINGWOOD VIC 3066
PH: +61 3 9415 7677
FAX: +61 3 9415 7655
KEY STAFF: Greg Ginger:
Managing Director, Martin Tyrell:
Production Manager.
Theatrical and Corporate Sound,
Communications and CCTV
Systems including Milron and
Sennheiser radio microphones,
EAW and Tannoy speakers, Crest
amplifiers, BSS Processing, Crest
and Allen Heath Consoles, Sony
MidiDisks, Dennon replay
equipment, quality production
services for theatrical, corporate
and special events.
Experience the Difference.

Showcase Productions PTY LTD

Unit 10/136 Cochranes Road
MOCRABBIN VIC 3189
PH: +61 3 9555 1991
FAX: +61 3 9555 9220
EMAIL: show-case@bigpond.com
KEY STAFF: George Gobairai:
Managing Director, Toni Stefan:
Administration.

SOUND SOLUTION AUSTRALIA PTY LTD

9 Union Street
SOUTH MELBOURNE VIC 3205
PH: +61 3 9686 4755
FAX: +61 3 9686 4766
EMAIL:
soundsolution@bigpond.com
WEB: www.users.bigpond.com/
sounsolution
KEY STAFF: David Rees: Sales
Manager, Tony Shanahan: Hire
Manager, Pete Rickard: Workshop.
Audio Production services for;
festivals, dance parties, touring,
corporate events, presentations
From component hire to full
production management.
Meyer MSL3 + 650R2, Martin
wavefront subs, QSC + Yamaha
amplifiers, Meyer processors, BSS
Omnidrive, Yamaha PM3000/40,
Allen & Heath GL4000/40, Klark &
Audient equalisers, Symmetrix &
Drawmer gates, dBx compressors,
T.C. Electronic & Yamaha FX,
Sennheiser wireless mics & in-
ears.

System Sound

10-13 Porter Street
PRAHAN VIC 3181
PH: +61 3 9529 2633
FAX: +61 3 9529 4897
EMAIL: cford@systemsound.com.au
KEY STAFF: Colin Ford: General Manager.

Troy Balance Australia

7 Union Street
SOUTH MELBOURNE VIC 3205
PH: +61 3 9699 3844
FAX: +61 3 9696 1125
KEY STAFF: Jenny Davidson: Production Manager, Dave Wignall: Production Assistant, Mick Lagler: Operation Manager.

Troy House of Music P/L

568 Chapel Street
SOUTH YARRA VIC 3141
PH: +61 3 9827 9955
FAX: +61 3 9827 0871
EMAIL: troy@troymusic.com.au
KEY STAFF: Luke Troy: Manager, Justin Dare: Hire Manager

VIC.

AV/STAGING

Audio Visual Dynamics

5/186-202 York Street
SOUTH MELBOURNE VIC 3205
PH: +61 3 9699 3788
FAX: +61 3 9690 8850
EMAIL: info@avdynamics.com.au
KEY STAFF: Peter Worth: Managing Director, Drew Morrow: Operations Manager, Luke Vanden Berk: Accounts Manager.

CLIPSAL VISION
SUPER SCREEN

Clipsal Vision Super Screens PTY LTD

State office in
DANDENONG VIC 3175
PH: +61 8 8445 9600
FAX: +61 8 8268 6755
EMAIL superscreen@clipsal.com.au

WEB www.clipsalvision.com.au
KEY STAFF: Angelo Russo: Sales & Marketing, Cam Johnson: Operations, Geoff Ellery: Managing Director

Durham Audio Visual Hire

65 Haig street
SOUTH BANK VIC 3006
PH: +61 3 9690 2288
FAX: +61 3 9696 4251
EMAIL: hire@durhamav.com.au
WEB www.durhamav.com.au
KEY STAFF: Gary Ashmore: General Manager, Ian McRae: Sales, Martin Camilleri: Operations.



GEARHOUSE MELBOURNE

2/290 Salmon Street
PORT MELBOURNE VIC 3207
PH: +61 3 9674 1100
FAX: +61 3 9674 1122
EMAIL:

melbourne@gearhouse.com.au
WEB: www.gearhouse.com
KEY STAFF: Rhonda Walker: Manager, Frazier Watkins: Sales Manager.

As the world's leading provider of presentation and staging services the Gearhouse Group consists of specialist divisions focused on your event success. Corporate Presentations, Themeing, and set building specialist lighting and sound, Exhibitions, Equipment sales, design and installation, concert video and lighting combine to ensure that Gearhouse has the right solution for you.



HAYCOM STAGING

29 Grattan Street
PRAHRAN VIC 3181
PH: +61 3 9529 3044
FAX: +61 3 9529 1893
EMAIL: info.mel@haycomstaging.com.au
WEB: www.haycomstaging.com.au
KEY STAFF: Alan Hay: Managing Director, Chris Browne: General Manager, Philip McShane: national sales & marketing manager, Ron Cairns: technical Manager.

Established in 1973, Haycom Staging has grown to become the largest independently owned audiovisual staging company in Australia, having consolidated a reputation for superior service and expertise in the area of large screen projection and corporate theatre.

We can supply Technical Directors, show crew and all equipment, including the famous Hughes cinema quality projectors. Offices in Sydney, Melbourne, Brisbane, Adelaide and Perth.

Premier Lighting Services

433 Graham Street
PORT MELBOURNE VIC 3207
PH: +61 3 9646 4522
FAX: +61 3 9646 6020
EMAIL: premier@premierlighting.com.au
KEY STAFF: Shane Jacobson: General Manager, Andrew Holmes: Director, Bob Prosser: Director.

Staging Connections Melbourne

101 Roden Street
WEST MELBOURNE VIC 3003
PH: +61 3 9329 5599
FAX: +61 3 9329 3396
EMAIL: bkneebone@stagingconnections.com.au
WEB: www.stagingconnections.com.au
KEY STAFF: Bill Kneebone

Tasman AV

6 Hood street
COLLINGWOOD VIC 3066
PH: +61 3 9416 2255
FAX: +61 3 9419 7041
EMAIL: sales@tasmanav.com.au
WEB: www.tasmanav.com.au
KEY STAFF: Burak Sunter: Multimedia Projectors, Darrin Simpson: Digital Video Production, David Budge: NLE Computer Editing.

VIC.

OTHER

Australian Costumers' Guild

PO Box 322
BENTLEIGH VIC 3204
PH: +61 3 9457 4061
EMAIL: stiltskin@netspace.net.au
WEB: www.vicnet.net.au/~costume/
KEY STAFF: Christopher Ballis: President, Kathrine Ashton: Membership Services, David Scanlon: Treasurer.

ICR Computer Rentals PTY LTD

34/756 Burwood Highway
FERNTREE GULLY VIC 3156
PH: +61 3 9752 3999
FAX: +61 3 9752 3789
EMAIL: icr@bigpond.com.au
WEB: www.isr-rentals.com.au
KEY STAFF: Virinder Gill: Senior Sales Engineer, Greg Gamblin: Sales Representative.

SHOWTECH
RIGGING
Australia

SHOWTECH AUSTRALIA PTY LTD & SHOWTECH RIGGING PTY LTD

510 Williamstown Road,
PORT MELBOURNE VIC 3207
PH: +61 3 9645 4133
FAX: +61 3 9645 4637
EMAIL: robyn@showtechaustralia.com.au
WEB: www.showtechaustralia.com.au
KEY STAFF: "Tiny" Good: Director, Robyn Good: General Manager. Entertainment technical and uncommon services. Products and services include: Rigging, staging, scaffold, set construction, ground support, roof and Truss systems, Big Top circus tent, box Truss, Tri-Truss, chain motors, drain blocks, drapes, rigging accessories and hardware. All crew requirements: Riggers, loaders, scaffolders, technical and production managers etc. Contact us for a company profile to be sent directly to you or see our website.

CONCERT & CORPORATE PRODUCTIONS

- Event Management
- Concert Lighting
- P.A. & Audio Visual Equipment
- Site Co-ordination
- Production Management
- Corporate Lighting
- Staging & Ground Support Hire
- Stage Management

286 Aberdeen Street, West Perth, WA 6005
Fax: (08) 9328 9529
Mobile: 0411 865 045
Email: ccp@iinet.net.au
Web: www.iinet.net.au/~ccp

We can supply all your requirements
for that special event
(08) 9328 9504

VIC.

**W.A.
COMPLETE
PRODUCTION
COMPANY**



**AVLA (AUDIO VISUAL
LIGHTING AUSTRALIA)**

19 Regal Place
EAST PERTH WA 6004
PH: +61 8 9221 1888
FAX: +61 8 9221 1444
EMAIL: production@avla.com.au

WEB: www.avla.com.au
KEY STAFF: Grant Ettrick:
Technician/Audio Engineer, Dik
Welland: Lighting Technician,
Dave Trapp: Operations Manager,
Dan Norgard: Hire Manager, Mike
Bird: Production Manager, Paul
Raphael: Sales Manager.
WA's Premier Service Hire Sales &
Production Company.

Catering to All markets from
Corporate Launches to Churches,
Club to Concert, there is nothing
we can't do.

Experienced operators and
technicians in all facets of Audio,
Visual and Lighting means we get
the job right first time on time!
Audio Hire & Production
Adamson & MSR Concert & Club
Systems

EV & RCF Corporate systems
Lighting Hire & Production
WA Largest range Of Moving &
Intelligent Lights

Martin MAC 250, 300, 500 & 600
Clay Paky Golden scan 3 & HPE
Clay Paky Mini Scan 300 & HPE
Clay Paky Stage Light 300 & Stage
Zoom 1200

Architectural & Outdoor Lighting
Searchlights

Laser - Club & Corporate
Display Lighting
Penn Fabrications Trussing
DATA Projectors

**CONCERT CORPORATE
PRODUCTIONS**

286 Aberdeen street
WEST PERTH WA 6005
PH: +61 8 9328 9504
FAX: +61 8 9328 9529
EMAIL: ccp@iinet.net.au

WEB: www.iinet.net.au/~ccp
KEY STAFF: Tim Bradsmith:
Managing Director, Les Cross:
Production Manager, Camille
Bradsmith: Administration.
Event management
Production Management
Concert Lighting
Corporate Lighting
Staging Hire
Ground support Hire
Site Co-ordination
Stage management
We can supply all your production
requirements for that special
event.

PHASE 1 AUDIO

286 Aberdeen Street
WEST PERTH WA 6005
PH: 61 8 9227 7979
FAX: 61 8 9227 5011
EMAIL: phaseone@iinet.au
KEY STAFF: Jon Caisley: Production
Co ordinator, Dave Caisley:
Engineer, Dean Harris: Engineer.
Concert, Corporate, Sporting and
Festival Events. Phase 1 Audio
offers a professional approach to
special events ranging from
seminars and awards nights to
sporting fixtures and large
concerts. Our inventory includes
Martin W8C, Apogee, QSC
Amplifiers, BSS, Allen and Heath
and RCF.

Tropo Sound

66 Hunter Street
BROOME WA 6725
PH: +61 8 9192 2394
FAX: +61 8 9193 5690
EMAIL: tropo@comswest.net.au
KEY STAFF: Mick Connolly: Proprieter,
James Edwards: Engineer, Brett
Lyons: Engineer.

**W.A.
LIGHTING**

**AVLA (Audio Visual Lighting
Australia)**

19 Regal Place
EAST PERTH WA 6004
PH: +61 8 9221 1888
FAX: +61 8 9221 1444
EMAIL: production@avla.com.au

WEB: www.avla.com.au
KEY STAFF: Grant Ettrick: Technician/
Audio Engineer, Dik Welland: Lighting
Technician, Dave Trapp: Operations
Manager, Dan Norgard: Hire Manager,
Mike Bird: Production Manager, Paul
Raphael: Sales Manager.

Production Services Australia

Swan Street
YOKINE WA 6060
PH: 61 8 9440 4400
FAX: 61 8 9440 4400
EMAIL:
production_services@yahoo.com
KEY STAFF: Jay Iseppi: Managing
Director

**W.A.
AUDIO**

AAA Productions

PO Box 4295
MYOREE BUSINESS CENTRE WA
6960
PH: +61 8 9317 2055
FAX: +61 8 9317 1566
EMAIL: aaa@iexpress.net.au
KEY STAFF: Neil Campell: Director,
Simon Hunt: Director, Guy Smith:
Senior Audio Technician.

AUDEX Concert Sound PTY LTD

251 James Street
NORTHBRIDGE WA 6003
PH: +61 8 9328 3188
FAX: +61 8 9227 7161
KEY STAFF: Keith Cramond: Director,
Ray Godfrey: Production manager.

**AVLA (Audio Visual Lighting
Australia)**

19 Regal Place
EAST PERTH WA 6004
PH: +61 8 9221 1888
FAX: +61 8 9221 1444
EMAIL: production@avla.com.au
WEB: www.avla.com.au
KEY STAFF: Grant Ettrick: Technician/
Audio Engineer, Dik Welland: Lighting
Technician, Dave Trapp: Operations
Manager, Dan Norgard: Hire Manager,
Mike Bird: Production Manager, Paul
Raphael: Sales Manager.

Production Services Australia

Swan Street
YOKINE WA 6060
PH: 61 8 9440 4400
FAX: 61 8 9440 4400
EMAIL:
production_services@yahoo.com
KEY STAFF: Jay Iseppi: Managing
Director

**W.A.
AV/STAGING**

**CLIPSAL VISION
SUPER SCREEN**

**Clipsal Vision Super Screens
PTY LTD**

State office in
MALAGA WA 6062
PH: +61 8 8445 9600
FAX: +61 8 8268 6755
EMAIL: superscreen@clipsal.com.au
WEB: www.clipsalvision.com.au
KEY STAFF: Angelo Russo: Sales and
Marketing, Cam Johnson: Operations,
Geoff Ellery: Managing Director.

Production Services Australia

Swan Street
YOKINE WA 6060
PH: 61 8 9440 4400
FAX: 61 8 9440 4400
EMAIL:
production_services@yahoo.com
KEY STAFF: Jay Iseppi: Managing
Director

Staging Connections Perth

34 East parade
EAST PERTH WA 6004
PH: +61 8 9221 4111
FAX: +61 8 9221 4991
EMAIL:
mjones@stagingconnections.com.au
WEB: www.stagingconnections.com.au
KEY STAFF: Merv Jones

**NEW
ZEALAND
COMPLETE
PRODUCTION
COMPANY**

ROBERT BARCLAY LIMITED

PO Box 47-654
PONSONBY AUCKLAND NZ
PH: +64 9 300 7596
FAX: +64 9 300 7595
EMAIL: rbcuelto@ihug.co.nz
KEY STAFF: Robbie Barclay: Director,
Pa.I Ashby: Hire Manager

NEW ZEALAND

LIGHTING

Kenderdine Electrical LTD

8 Burrett Avenue
PENROSE AUCKLAND NZ
PH: +64 9 525 2200
FAX: +64 9 525 2233
EMAIL: ccrmck@ihug.co.nz
WEB: www.kelpls.co.nz
KEY STAFF: Chris McKenzie: Sales,
Zeb Mansell: Hire manager, Paul
Noble: Projects.



Oceania Audio & Lighting

9/1678 Taylors Road
MORNINGSIDE, AUCKLAND, NZ
PH: +64 9 849 3114
FAX: +64 9 849 3307
EMAIL: hire@oceania-audio.co.nz
KEY STAFF: Greg Peacocke: Director,
Paul Jeffery: Technical Director, Simon
Garrett: Lighting Manager.

Professional Lighting Services LTD

8 Burrett Avenue
PENROSE AUCKLAND NZ
PH: +64 9 525 2200
FAX: +64 9 525 2233
EMAIL: ccrmck@ihug.co.nz
WEB: www.kelpls.co.nz
KEY STAFF: Chris McKenzie: Sales,
Zeb Mansell: Hire manager, Paul
Noble: Projects.

NEW ZEALAND

AUDIO

THE SOUND PEOPLE LTD

28 Bedford Row
CITY CHRISTCHURCH 8001 NZ
PH: +64 3 379 3393
FAX: +64 3 379 3310
EMAIL: sound@soundpeople.co.nz
KEY STAFF: Murray Ward, George
Frith, Michael Waldegrave.



Oceania Audio & Lighting

9/1678 Taylors Road
MORNINGSIDE, AUCKLAND, NZ
PH: +64 9 849 3114
FAX: +64 9 849 3307
EMAIL: hire@oceania-audio.co.nz
KEY STAFF: Greg Peacocke: Director,
Paul Jeffery: Technical Director, Simon
Garrett: Lighting Manager.

NEW ZEALAND

AV/STAGING

AVI-AUDIO VISUAL INTERNATIONAL

18 Merton Road
ST JOHNS AUCKLAND 1005 NZ
PH: +64 5 280 763, +64 5 262
1123
FAX: +64 5 263 5896
EMAIL: info@avi.co.nz
KEY STAFF: James Storrie:
Technical Director—International,
Jennie Cowan: International Co-
ordinator.
Technical Event Management
Conference Productions
plus Administration & Travel
Three Digital Audio & Video
recording Suites, Non Linear
Editing, Mastering, Duplication
and Translation (on site or in our
studios)
Audio Visual Equipment Hire
Technical Support
AVI — A WORLD OF EXPERIENCE.

BOYD AV HIRE

21 Railway Avenue
LOWER HUTT WELLINGTON NZ
PH: +64 4 569 1171
FAX: +64 4 569 1173
EMAIL: wgtn@boyd.co.nz
WEB: www.boyd.co.nz
KEY STAFF: Colin McLellan:
Wellington Hire Manager

BOYD AV HIRE

4 Cawley Street
EUBRELIE AUCKLAND NZ
PH: +64 9 579 6224
FAX: +64 9 579 9969
EMAIL: avhire@boyd.co.nz
WEB: www.boyd.co.nz
KEY STAFF: Haig Walker: National
Manager, Andrew Hunter: Hire
Supervisor.



Clipsal Vision Super Screens PTY LTD

Office in
PAKURANGA AUCKLAND
PH: +61 8 8445 9600
FAX: +61 8 8258 6755
EMAIL: superscreen@clipsal.com.au
WEB: www.clipsalvision.com.au
KEY STAFF: Angelo Russo: Sales &
Marketing, Cam Johnson: Operations,
Geoff Ellery: Managing Director.

John Herber LTD

620 Cranford Street
CHRISTCHURCH NZ
PH: +64 3 3352 4588
FAX: +64 3 3352 4580
KEY STAFF: Graeme Philip: Managing
Director, Diane Philip: Director, Mark
Philip: Director.

Shipleys Audio Visual LTD

193 Peterborough Street
CHRISTCHURCH NZ
PH: +64 3 379 5166
FAX: +64 3 379 0010
EMAIL: shipleys@shipleys.co.nz
WEB: www.shipleys.co.nz
KEY STAFF: Phil Wright: Senior
Staging Technician, Paul Hermans:
Operations Manager, Bruce Whitnall:
Co Manager.

Be Listed Here.

Call 1-800 635-514 or fax +61-2-9876-5715

**Subscribe and beat the GST! Pay our stand-
ard rates now: 1 or 2 year subs save money!**

PLUS, you get your mag before the newsagent does!

Free call: 1-800 635-514 or fax
+61-2-9876-5715 from O/S
AUST: \$48, (12 months) or \$79
(2 years). A\$80, Asia A\$80, USA
A\$115, Europe/UK A\$125.

Connections

This is a bit of a first for Nine, where there are usually just two audio lines sent to Beta. It arose because Stephen Smith at Tracks (where they do audio post for Hi Five) suggested it would be more cost effective.

Steve Korres explains: "It allows more flexibility, we dump the audio in one run on each take with the vision. The show is then cut on Avid (vision hardware) then sent to Tracks for Fairlight (audio post) treatment. They can put in effects and tweak on the fly".

The four tracks also make it easier to drop in a foreign voice track if they show is sold overseas.

Readers outside TV may be confused about four tracks, in a 48 track world. Indeed there are a stack of Sony PCM-800 (re-badged Tascam DA-88) 8 track DTRS machines in the control room. Plenty of shows go to audio post as multitrack projects, with digital audio tapes synced to vision by timecode. But this obviously lengthens the audio post process, since all the multitrack tapes need to be run in sync with vision, usually downloaded onto hard disk first. One PCM-800 is recording the show this day, as a backup.

Down on the floor, the effects mic (a Shoeps) under the floor is collecting stomps and clomps, and a lonely Shure VP 88 stereo M/S mic is up in the grid, to capture that kiddy-crowd angelic singing stuff. There's also a couple of dishes (parabolic dish with small mic inside) beaming away towards the crowd to catch ambience.

The hardest part of the gig is to capture the spoken words at the end of the song - the first time. And, to make a transition from nice, clean premixed CD song vocals, to slightly breathless live voices.

On other days, the show is very demanding. "All the vocals on the 1st and 2nd days are live", says Steve. "It is more like a drama, in that the cast need to memorise a lot of lines and then sing their songs live to keep continuity with audio. So basically you have



Audio director Steven Korres and assistant Luke Armstrong (rearst).

Lights - camera - action!

Hi-5 is being shot at Channels 9's main studio working in a half configuration with a full 180° cyc. *The Footy Show* and *Catchphrase* are also shooting in this studio. Lighting director Rob Cottrell works a six day week on the show, filming five episodes in that time. There is one central theme for the week, this particular week the theme was Animals.

"Saturday is rigging day, Monday, Tuesday and Wednesday are record days whilst Thursday and Friday are rehearsal days," said Rob. "We'll finish this run in nine weeks time with 45 episodes shot."

Although this is a Channel 9 production the last series was actually filmed at the ABC studios as there was not a studio available at the Channel 9 headquarters. Rehearsals are still undertaken at the ABC studios due to no studio available at Channel 9.

"I was the only lighting person from Channel 9 who went over there," said Rob. "We used their gear and personnel. Lighting

Adjustable Wrench Pocket Tool Kit

Don't feel like spending \$140 on a Leatherman or Victorinox pocket knife? Well, maybe you might be interested in this cheap alternative. It is pretty simple - with two blades (one of which doubles as a slotted screw driver), Phillips head screw driver, file - oh and needle nose pliers and adjustable wrench.

Being a fairly inexpensive tool, you can't expect it to do everything. I found the pliers and wire cutters to be a bit under-engineered, but they are great for delicate work. One good attribute that this tool is that the pliers are lightly sprung open, so as you release your grip on them, the "nose" opens by itself.

I wouldn't consider it as the tool to grab everytime, but it is an excellent companion tool to have strapped on your bum bag.

- Phone Kincome for your nearest supplier +61 (0)3 9518 8300
- Au \$33.90 (ex tax)



DisplayMate for Windows

This piece of software is an interesting little tool for the video technician. It generates test patterns that are displayed on the screen of a PC for the purposes direct outputting these as video signals for testing. There are a few different editions of this software, but the Kayye Consulting Edition of DisplayMate includes some patterns not found on any other version. These include pattern to measure the quality of the optics of a projector, as well as some HDTV set up patterns.

Other test patterns included allow for the proper set up of brightness, contrast, convergence and gray scale as well as an anamorphic convergence pattern critical to properly displaying program material from DVD-ROM. This new version is the most comprehensive collection of DisplayMate test patterns available to date.

Gadget Grab

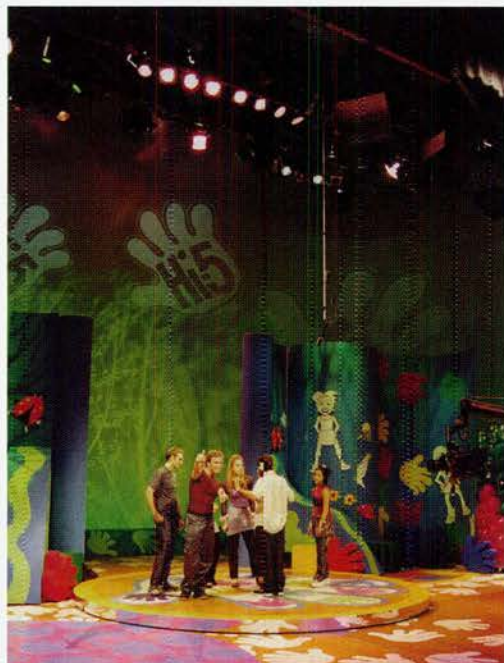

dialogue between 2 or 3 people then straight to a live song with 2 to 5 vocals, then more dialogue between 2 to 5 people, and so on. So we do a segment as it runs, with many CD and dialogue cues with some live instruments and effects. Hence the need for an Assistant Audio Director."

"The cast works hard to get the singing right on the day as well as remember many lines. It is also important for Audio to get the mix right every time or as humanly possible.

The morning passes quickly as the 'Five' and the audience tire. It's cool how the floor manager controls the kiddies, who are all really happy to be there.

Gosh, TV is so polite. The floor crew even have Iced VoVo's on tap. I think I might send my CV to Nine!

wise, there was a huge difference in the way they work. Here at Channel 9, there's myself and two others to light the show whereas at the ABC they had a Lighting Director, Console Operator, Floor Assistant, and three night riggers. Here we do everything, however the equipment at the ABC is nowhere near as good as ours. We've got digital cameras and they have old tube cameras.

At the ABC Rob was using Technobeams and the light level had to be twice as bright than at Channel 9 to satisfy the tube cameras.

"Here the cameras run at around a F3 stop and to achieve that we need 64 candles but at the ABC we needed 124 candles," he explained. "Also, with the tube cameras you couldn't shoot a light itself because you'd get flare."

Rob was using six Vari*lite VL6b's and six VL5's on hire from Jands although they also use Lots Of Watts for hire gear. The cost of the hire is split with *The Footy Show* and *Australia's Funny Home Videos*. Several specialised gobos were made up for the VL6b's, a process which involves sending your artwork to Texas.

Hire costs are tax deductible, however last years lighting hire costs for about four months would have paid half the purchase price of some moving lights. The positive aspect is that at least Rob can alternate his choices.

"The tricky thing is that they tend to shoot at all angles, so I have to be careful to keep everyone 'even', filling in all angles. I tend to light more front on as I can get lower light from there and they tend to work front more often. I have a 360° arc, basically two 5K front sources, two 2K side sources, two 5K back sources and overhead par cans for each area. There's also open whites for the children in the audience. There are six set positions in the studio."

Rob was making extensive use out of a rather ancient 1K RDF projector which at the ABC he hardly got a punch out of but, with the digital cameras, he can now safely put gels on it. The RDF has a 5:1 lens in it and Rob finds it very useful for projecting large scenes on the cyc. He is pictured with the 'classic' below.

"It has a moving cloud gobo which I use when the band go 'flying'," said Rob. "I don't get as much light out of it as the VL's but we've just cleaned it up and got a new globe in it so I can actually put a colour, like 121 green, on it. I can change lenses from wide to short. It's got different attachments to go on the front of, the spiral patterns and 'suck and blow' spinning effects are fantastic. You just can't get those effects with intelligent lights."



-Cat Forcer

Bag

with John Grimshaw

The Kayye Consulting edition of DisplayMate is HDTV-ready. What's that mean? Well, because DisplayMate is HDTV ready and will automatically produce a complete set of accurate 16:9 test patterns, when it is run on HDTV video boards all of the test patterns will output at HDTV (16:9) aspect ratio as well as the standard PC 4:3 and 5:4 aspect ratios.

- Kayye Consulting, Inc - www.kayye.com
- DisplayMate for Windows - US\$90

3mm Black Sash

Believe it or not, thin black sash can be a little difficult at time to source - particularly if you want to get the skinny 3mm version. However, Theatre Equipment (which is incidentally under the new management of Michael Rafferty) have a product that they call VB 3mm. The VB stands for "Vertical Blind" not some brand of beer, and it comes on a 100m roll.

- Theatre Equipment Pty Ltd - Ph +61 (0)2 9519 6099
- VB 3mm - Black \$49 ex tax

Who Supplies The Cheapest Batteries?

This is a question that has regularly vexed me as I search for the best priced, high quality batteries that can be found. At the moment, I am sticking to recommending the Energizer Industrial Alkaline batteries, as they seem to be the current favourites for pro radio microphone operators. The current winner is below, but I would welcome anyone that can tell me who will beat these prices - and it has to be a price that ANYONE can get.

- TLE Electrical - (offices throughout Australia)
- 9V (Energizer Industrial Alkaline) - \$3.55ea
- AA (Energizer Industrial Alkaline) - \$0.99ea
- AAA (Energizer Industrial Alkaline) - \$1.07ea

If you know of any devices that are worth mentioning here (or better options to the ones I have listed), please let me know.

Email: john@conpub.com.au

Mail: Dr G, Cornections Publishing, PO Box 439, Epping NSW 2121, Australia. Fax: Attention Dr G, +61 (0)2 9876 5715

How to do it

TOM MISNER'S PRACTICAL STUDIO TECHNIQUES

- DIGITAL AUDIO (Part 22)

DOUBLE OVERSAMPLING

One technique used to improve CD and sampled sound is known as double oversampling. Instead of processing the output at 44.1 kHz, we double the sampling rate to 88.2 kHz. This moves the beginning of the first band of ultrasonic noise in the resultant analog signal from 24.1 kHz to 68.2 kHz. This, in turn, eliminates phase shift and ringing that can result from the use of a very steep filter in the 20 kHz range. The use of double oversampling and digital filtering yields a phase-coherent signal that lacks the harshness of some analog-only filtered models.

TIME CODE

Time code has only come into common usage in the music studio within the last few years, although the history of its development spans roughly thirty years.

In 1956, the Ampex corporation introduced the quad-head video tape recorder. They had developed a new process of recording pictures onto magnetic tape, a medium which offered low cost and remarkable flexibility. The main problem was the editing of the video and audio signals.

Working with traditional film, it was possible to locate the appropriate cutting marks via the sprocket holes. Video tape offers no sprocket holes or any other physical indication of the information recorded there. The video signal is recorded diagonally across the tape and cannot be edited by the cut-and-splice process.

Initial editing attempts were made with the use of an electronic counter, which at best was only roughly accurate and suffered from tape slip problems, becoming more inaccurate towards the end of the tape.

In 1963 the control pulse (CTL Pulse) was introduced as an alternative to mechanical counter editing. It remains a standard feature of video recorders today, an 'electronic sprocket-hole' that can be counted and referred to as a timing and positional reference.

This system can suffer from dropouts and missed pulses due to poor tape-to-head contact at fast wind speeds. Like the mechanical counter, it must be reset at the start of the program, and any count errors that occur can accumulate to cause a wide discrepancy between the counter reading and actual tape position.

The solution to these problems first appeared in 1967, with the proposal that an actual numeric value - a digital representation of the time position of each video frame - be encoded on the tape, along with the video picture. This time coding system would allow the absolute identification of each frame, without susceptibility to cumulative errors or the need to begin playback from a known point on the tape. In 1972 this system was adopted by the SMPTE (Society of Motion Picture and Television Engineers) and by the EBU (European Broadcast Union), who established the time code standards with which we are familiar today.

The standards adopted by the SMPTE and the EBU differ slightly - largely due to the dissimilar television standards existing in North America and Europe. It is referred to as the SMPTE/EBU time code standard, and is in wide use today.

Time Code Types (LTC or VITC)

Time code was originally developed in a form to be recorded on an auxiliary audio channel of the video recorder, similar to an audio signal, and recorded continuously along the length of the tape - thus the designation Longitudinal Time Code (LTC). It is the most common form of time code, and is the only one directly applicable

to audio tape recorders.

As long as the video recorder is playing back at, or close to, its normal play speed, LTC recorded on an audio track is available and easily readable. The frequency of the LTC signal is proportional to tape speed, of course, and at high fast wind speeds can rise past the frequency response of the recorder's reproduce system and become unreadable; at extremely low speeds, the LTC signal can disappear completely. This limitation of LTC in video editing, where much time is spent in slow and freeze-frame modes, led to the development of a time code format that could be recorded as part of the video signal itself.

This code, inserted in the video signal in the gap between visible frames known as the vertical blanking interval, offered the advantage of being readable under any circumstances where a picture is available, and became known as Vertical Interval Time Code (VITC). Well suited to the business of video editing, VITC brings with it some major limitations:

1) VITC cannot be used with audio recorders.

2) VITC cannot be written on tape before or after recording of the video signal, as the two are interwoven on the same recording path.

LTC is far more common than VITC, particularly where audio production is involved, as it offers great simplicity and flexibility of use.

The Structure of LTC

A numeric code (binary word) is recorded alongside each video picture, or frame, in order to uniquely identify each picture and to determine its position in the original sequence of frames. The simplest coding would involve consecutively numbering frames from some defined start point, beginning with '1' and continuing ad. infinitum; of course, we could use numbers, letters, or any other sequence that seemed appropriate. In fact, a sequence of real time units was deemed most useful, as this could fulfil a dual function: identification of individual frames, and indication of elapsed time in a natural and comprehensible form.

The units of SMPTE/EBU time code are hours, minutes, seconds and frames, the actual time value of the frame being dependent on the time code standard in use. In North America, where the NTSC television standard prevails, there are 30 video frames per second therefore there are 30 frames per second (fps) in the time code (from 0 to 29). In Europe and Australia, the video frame rate is defined as 25 fps, in accordance with the PAL television standard. For film, a frame rate of 24 fps is used.

SMPTE/EBU time code allows us to identify each video picture individually, by assigning a time value to each frame and encoding this on the tape. This code takes the form of a collection of 0's and 1's, forming a digital word. In addition to the hours, minutes, seconds and frames values, it also holds other essential information: control bits, user bits, and the sync word. The exact function of these will be examined shortly; next month we look at the detail of the encoding process.

This is extracted from the top selling book: PRACTICAL STUDIO TECHNIQUES, by Tom Misner. ©Tom Misner 1988. ISBN0 646 16704 9. Retail: \$40.00. Available from book stores and music shops everywhere, also through the Connections Shop, call 1800 635 514. Tom Misner is the owner of SAE International.

Learn to Mix with the **best**

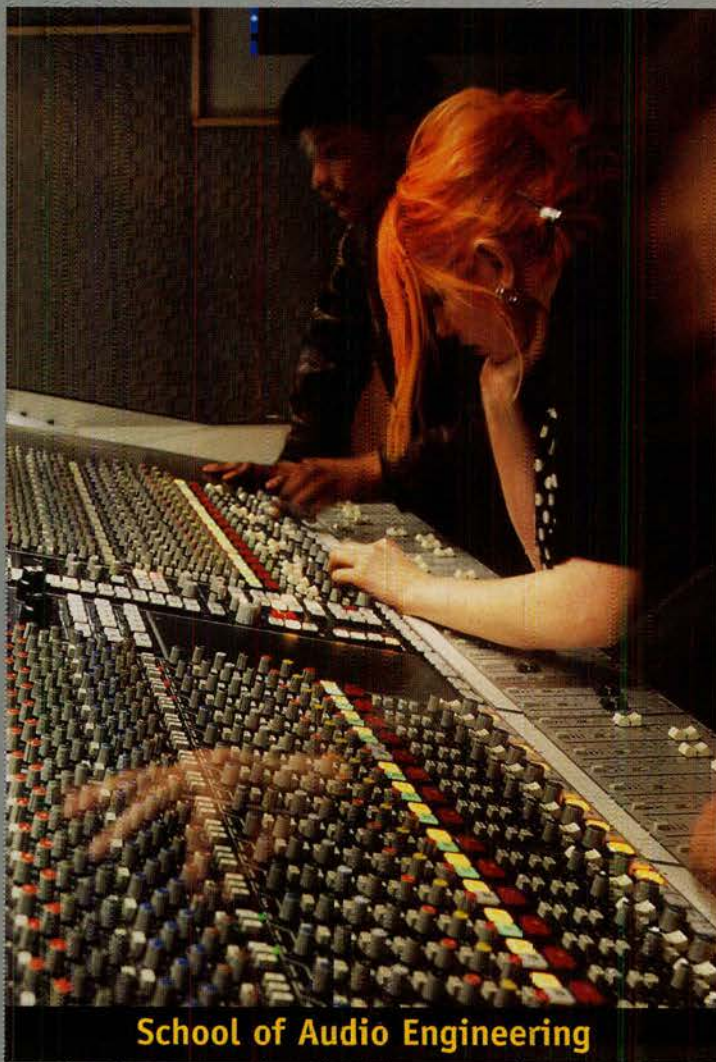

School of Audio Engineering



For more information and a free colour catalogue call any of these centres of educational excellence:

SYDNEY	55-57 WENTWORTH AVENUE, SURFY HILLS, NSW 2010, AUSTRALIA
MELBOURNE	2ND FLOOR, 14-16 FITZROY STREET, ST KILDA, VIC 3182, AUSTRALIA
PERTH	3-5 BENNETT STREET, EAST PERTH, WA 6004, AUSTRALIA
ADELAIDE	LEVEL 2, 282 GOUGER STREET, PO BOX 10411 GOUGER ST., ADELAIDE, SA 5000
BRISBANE	22 MAYNEVIEW STREET, MILTON, BRISBANE, QLD 4064, AUSTRALIA
HOBART	40 GEORGE STREET, NORTH HOBART, TAS 7000, AUSTRALIA
AUCKLAND	18 HEATHER STREET, PARNELL, AUCKLAND, NEW ZEALAND

recognised practical audio education

individual studio time

the best studio equipment

industry guest lectures

active graduate placement

limited enrolments

the only international audio school

the largest and first audio school

small theory classes

full university degree BA

industry recognised qualification

established 1976

30 colleges all over the planet

active student exchange program

Australian government approved in all states.

**ONLY the SAE programs guarantee you
50% credits to the degree**

Certificate - Diploma - Degree

* Australia exclusive educational association with
SOUTHERN CROSS UNIVERSITY - LISMORE

* International exclusive educational association with
MIDDLESEX UNIVERSITY - LONDON

* In cooperation in sound engineering with

WALT DISNEY Entertainment[®]

Stanberg
Training Center

www.sae.edu

How to do it

DUNCAN FRY'S LIVE SOUND MIXING SERIES

- EFFECTS (Part 3)

Spring Reverb

However, you still may come across a Spring unit now and then. AKG made a couple of them, so did Roland, and probably many others. They work exactly along the same lines as the one in your good old Twin Reverb guitar amp.

Basically a long coil spring(s) is excited at one end, and its random vibrations are picked up and amplified at the other. The spring keeps vibrating long after the original signal has stopped, giving the reverberation effect. The gain in the pickup stage is enormous, so these units have to be well shielded as they are very susceptible to hum.

Spring Reverbs are very MID efficient devices, and will usually have some EQ controls on the front to try to lessen the Mid response and boost the HIGH end. A good spring reverb should also have a very fast limiter on its Input, as signals with lots of transients like drums will make the spring physically Twang on each beat. If you do come across one it's best to keep it for vocals.

Also, if a drunk bangs into your effects rack while you have a spring reverb wound up (no pun intended!) the resulting CRASH sound from the PA system has to be heard to be believed!

Digital Reverb

Digital reverb is nothing short of a modern day miracle. These units are extremely flexible, having several programs for different reverb times and sounds; they are compact, most taking up 1 rack unit or less; they are reliable; and they are affordable.

Budget priced units have a range of preset sounds, and more expensive ones you can program yourself, or modify the factory presets and store them.

So you can easily set up the reverb to give you the sound of any place you like, from that of your favourite bathroom to the digital equivalent of Notre Dame cathedral, or any combination in between.

Like Digital Delays, they fall into 2 categories; those with knobs and those without.

Digital Reverbs With Knobs

One of the first of these was the Yamaha R 1000, with 4 different reverb, programs. This was extremely popular and easy to use.

R1000: How to get it to work:

Set the Input and Output controls to 2 o'clock, press one of the 4 reverb program switches (1 - short, through to 4 - long), set the Mix control to Reverb (hard Right), and bring up the return level on the console. If there is no reverb, then the Bypass switch is on. Switch it off and the reverb will appear. If you don't like the sound, there is sweepable 3 way EQ included on the front panel as well.

We're starting to see less knobs with the Lexicon PCM 60 and 70. The 60 has knobs for Input level, Mix and Reverb level, but

switches for the rest. There are 2 types of program, Plate (simulating Large mechanical Reverb plates, from studios) and Room. These programs can be modified with 4 switches for Small through Large, and 4 more switches for Short through Long. EQ is limited to Bass boost and Treble boost switches.

PC 60 & 70: How to get it to work

Basically, as long as the Input and Reverb levels are up, the Mix control is on Reverb (hard Right) and some switches are pressed, then this unit will work. Try all the switch combinations until you find some that you like, then make a note of them.

The Lexicon LXP 15 has a rotary knob to select your basic program, then a row of 'nudge' buttons to modify the parameters of that program.

A product from the Alesis company broke the cost barrier on digital reverbs and effects - the original Midiverb. This was a small plastic box looking like a remote control, affectionately nicknamed the 'soapdish', with 69 various reverbs and a few delay effects. There was also a Midifex which was all digital delay effects.

LPX 15: How to get it to work

By pressing the Up or Down buttons you can scroll through all these programs until you find one you like, and although you can't adjust them, there are plenty to choose from. The Midiverb 2 had the same package as the original, but the Midiverb 3 and 4 went 'up market' and are rack mount units, with control of some parameters via 'nudge' buttons.

MidiVerb 3 & 4: How to get it to work

Just press the Up or Down buttons until you find a program you like, then fine tune the parameters with the nudge buttons. An even smaller reverb from Alesis, the Microverb, took up just 1/3rd of a rack unit and had 16 different reverb programs.

Microverb: How to get it to work

Set the Input and Output controls at 2 o'clock (the Green LED will change colour to Orange then Red if the level is too high), set the Mix control to hard Right, and sweep the Program rotary switch around until you find one you like. Like the Midiverb, the Microverb has now grown to a single rack unit, with a lot more programs and EQ controls, but you work it in exactly the same way. The true successor to the original Microverb is the Nanoverb, with 18 preset programs in the same 1/3 rack unit package. You get it to work in exactly the same way.

This is extracted from the top selling book: LIVE SOUND MIXING, by Duncan Fry. © D.R. Fry 1998. ISBN0 646 11235 X. Retail: \$39.00. Available from book stores and music shops everywhere, also through the Connections Shop, call 1-800-635-514.

LIVE

PRODUCTION REPORTS

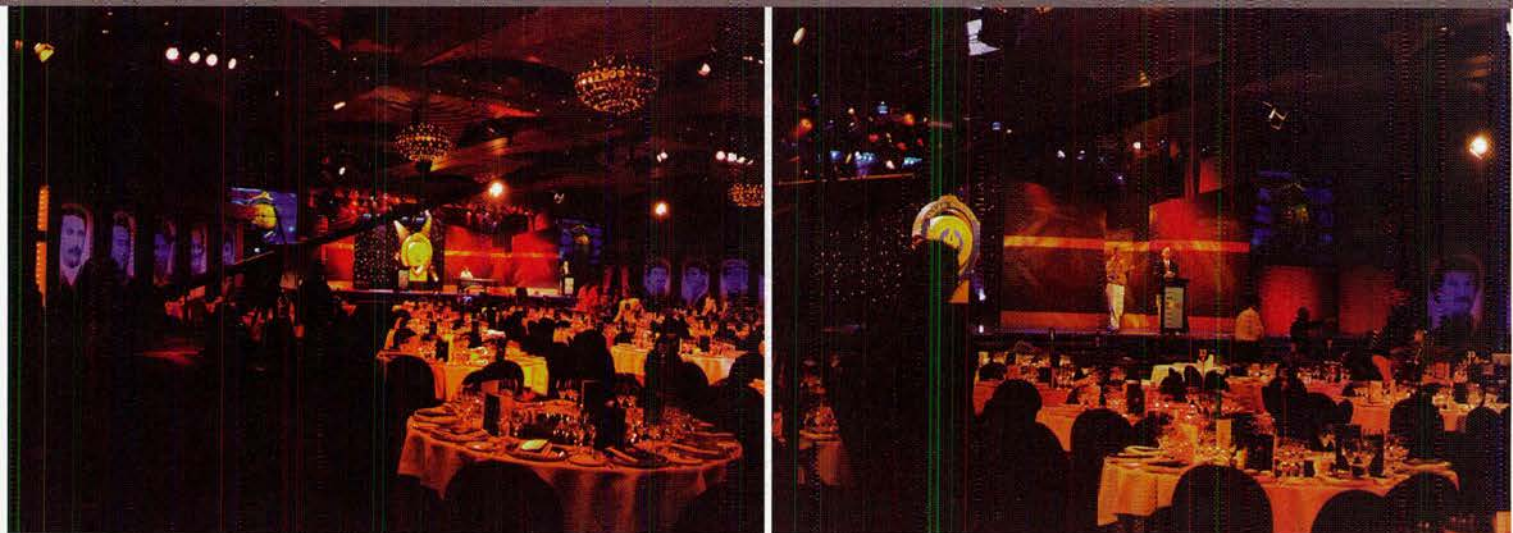

STAGING THE ALLAN BORDER MEDAL

A 'who's who' of Australian Cricket was present at the Palladium Ballroom at Melbourne's Crown Casino for the presentation of the inaugural Allan Border Medal. The stars of the current squad were there - Tugger, Warney, Junior, Gilly, Ponts, Pigeon and Meadow, as well as all the legends of the game, and Mark Taylor. The only notable absences seemed to be Sir Donald Bradman and Warwick Todd.

Basically a 'Brownlow Medal' count of cricket, Glenn 'Pigeon' McGrath won the overall Allan Border medal as well as Test Player of the Year, with Shane Warne taking away the award for the best One Day player of the year, and newcomer Brett 'Oswald' Lee picking up the Sir Donald Bradman Young Player of the Year Award.

Produced for television by Channel 9, the three hour telecast hosted by Eddie McGuire and Richie Benaud featured a live band, tape inserts and special guests, and was attended by an audience of 950 cricket enthusiasts. As in-house audio visual supplier for the Palladium, Staging Connections worked closely with the Channel 9 teams to ensure the first time event ran smoothly.

The ballroom was set up with four video projectors and screens in addition to the two cube walls permanently installed on either side of the stage. Channel 9 brought in nine cameras to cover the room, made up of a jimmy-jib, four pedestals, and four softpacks spread around the room for audience close ups.

Mike Hall and David Deveney from Staging Connections explained their role was the liaison between the venue, and the clients - the Australian Cricket Board and Channel 9.

"There's a lot of little things that need to be looked after that make it in total a big show but if you looked at any one component you'd think it's not all that big. Having four projectors and two cube walls is not that amazing these days in corporate theatre but you tack onto that another 25 monitors around the place and route four different feeds to them all and a couple of specialist bits here and there and it gets complex," explained David.

On behalf of the venue, Staging Connections provided a duty technician, draping and rigging services, and general provision of any emergency services such as last minute set requirements and audio visual equipment.

"We provided all of the technical liaison with the venue and all the visual components in the room and throughout the backstage area such as monitors and all the audience screens."

David explained the biggest factor on a show of this type is always control.

"Control was a bit different on this show because we split it due to the space in the room, and we went with the new idea that everyone seems to be going with of putting the show up one end of the room and the band at the other end of the room which is very interesting from an audio perspective, but it's a bit of a trend.

So in this situation, what they had to do because of the band at one end and the main stage at the other end was to break up the control. Foldback was right next to the band, FCH audio was on one side of the room, and lighting was up in the main big box. For the television side of it, all the audio and vision feeds ran out to Channel 9's OB vans parked outside the casino. Those signals were then sent back to Channel 9 in Richmond where most of the

continued over



Mike Hall, Technical Event Manager, Staging Connections at Crown Tower

STAGING THE ALLAN BORDER MEDAL

bits were put together, then a copy of the complete broadcast was sent back to the Palladium for the live audience to watch. And it was all live."

AUDIO

Darren Wheeler was one of three Channel 9 audio technicians running the event on the floor.

"We've worked in this room maybe six or seven times doing stuff like the Logies and the Footy Show so we know how it operates. As far as the TV side is concerned we've got it streamlined so we can get it in and out quite quickly.

"McLean's Audio provided the PA, so they had a crew of four guys operating for them on the night. Channel 9 had six guys for the television side of things, so there were two guys mixing the program, and a third guy mixing the music alone. Then there were three of us who did the running of the event on the floor, so we did all the patching of all the desks, and patching back to the trucks, running all the microphones and speakers, all the radio mics, and then the operation and the running of the show on the night, like taking the lecterns off the stage at ad break and then back on again, putting clip-on microphones onto guests, and all the basic runnings of the show."

Placement of the band at the back of the room rather than behind the stage meant that two PA's were required - one for the band which faced back towards the stage, and the main one for the rest of the room. Darren said the introduction of the second PA kept the audio guys on their toes avoiding potential feedback problems with the lectern microphones, and meaning delays were required.

A Yamaha PM4000 was used for FOH and a PM3000 for the music mix. The actual show mix within

the OB truck was done on an AMS Neve fully assignable desk.

Darren said a great variety of microphones were used. All the radio mics were Sennheiser, the main vocal mic was a Shure UHF radio system, and the bands' microphones were a range of Neumanns, Sennheisers, Beyer and Shures.

"We had Eddie and Richie backed up with lapel mics so if the lecterns died we had them to go to and so did the PA guys, so we were pretty confident it was all going to be okay.

"Technically there weren't any problems. During rehearsal we had a few problems with microphone splits but that was all fixed well before the show. The stage and band mics had to go to three areas - to FOH for the room mix, to the monitor mixer for the band, and they also have to go to the TV side of things, so to get the one mic signal to three areas it has to go through a splitting system. The ones we used from McLean audio were an active splitting system so we could take the mixes out three to four different ways to send to three to four different areas and the only problem we had was a bit of a mis-patch. So once we sorted that out it all ran smoothly."

Darren Wheeler



LIGHTING

Lighting Designer Rohan Thornton is no stranger to the Palladium having designed lights for several major events staged there including Logies and Footy Show telecasts.

"Fundamentally whenever we do anything there we take everything with us, it's more cost effective and our guys are used to working with particular equipment, and also we can be sure all the gear works," explained Rohan.

For moving lights, Rohan took the complete Channel 9 Coemar rig and hired 24 VL5's from Jands in Melbourne.

"All up I had 24 VL5's, 10 Coemar CF 1200 HE's, 16 CF 500 AL's, 12 Wybron 4" Coloram scrollers, 12 Par Colorams, 4 3-lite Colorams, about 150 profiles which were predominantly Source Fours supplemented with some Selecon Pacifics, 40 Janaro 2k's, about 160 par cans and some Source Four pars as well. We had a mixture of dimmers predominantly from Clearlight, and most of the other gear and scrollers came from Bytecraft."

For control, Rohan took Channel 9's Compulite Sabre with them and hired another Sabre from Clifton Productions so that one could be the dedicated moving light console operated by Andrew Eadis, and the other for all the analogue gear operated by Megan McGahan. All up five streams of DMX were used - two for analogue and three for automated.

Rohan's design included feature lighting for the set designed by Mal Nicholls, stage lighting for the overall look, as well as specials for the audience tables.

"To be honest the design came more out of economics than anything else. We had a very tight budget for this show. The set changed quite dramatically - it started out being a magnificent \$60,000 set and they ended up doing it for \$22,500, so we knew we would have a lot to do to get some variation out of the look. We made some decisions on the run, initially the designer had put a cyc in but it just didn't look right so we went with blacks and bud light.

"I'd been playing around with half-colours and gobos and soft projections so I came up with the design within the budget out of

Megan McGahan and Rohan Thornton



LIVE

that. But there were some particular production requirements which chewed up a fair bit of money, mainly the Hall of Fame reveal."

Rohan said the main difficulty of lighting a television event of this type is always needing to spend almost as much money lighting the audience as lighting the main set.

"And because we're fundamentally dealing in a three dimensional medium things change more so than in a stage show, particularly in the way the audience is set up and then with the cameras, so we tend to change things to suit camera angles which makes pre-programming pointless.

"I can honestly say in 18 years I've never been able to pre-programme anything. With possibly the exception of doing the patch on the console. Again the thing is that we tend to do a lot of 'one offs' and in very short time frames so we really don't get the opportunity."

To improve the situation, Rohan is hoping someone at Channel 9 will find him the money to buy a WYSIWYG system.

"I've done some training on it and I'd really like to start utilising WYSIWYG because I'm at the stage where I'd like to start doing a bit more with the shows but we just don't get the time to get any more subtle than we do."

Rohan said he was quite surprised by the widespread positive reactions to the Medal presentation.

"Generally with awards shows you do them and then you just wait for everyone to shit-can them in the papers the next day. I was all prepared to open up the paper and have every journo bag it, but it was totally the opposite.

"And you can always tell a show that will be a success because the crew don't like it, and you can tell when a show will be a flop because the crew are really into it. And so far history has proved that true."

• Mandy Jones

RADIAN

AUDIO ENGINEERING, INC.

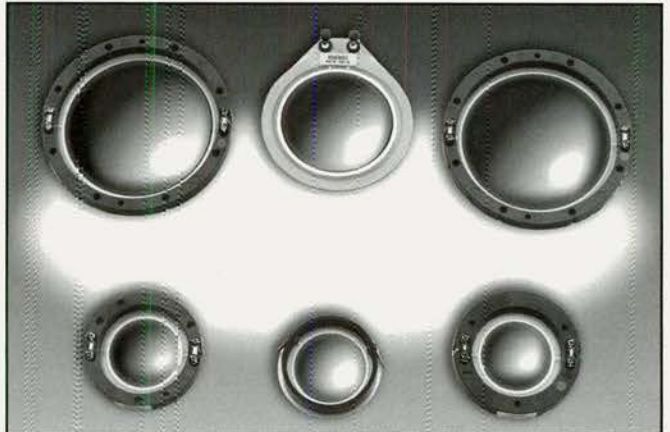

PREMIUM REPLACEMENT DIAPHRAGMS
FOR RADIAN®, JBL®, TAD®, ALTEC®, AND EMILAR®
COMPRESSION DRIVERS

Available from:

acoustic technologies

8-10 Staple Street, Seventeen Mile Rocks, Qld, 4073
Phone: (07) 3376-4122 Fax: (07) 3376-5793
Email: info@acoustic-tech.com.au

K&M rolls out your studio solutions

Konig & Meyer offer a range of stands, racks & trolleys to solve all your studio problems. Like the 28205 rack trolley (right) with 17 rack units down the front & 7 on top. Or the 42020 rack wagon (below) with 9 rack units in front, 12 in the tilting tray & optional add-on brackets to add another 9 rack units above the tray.

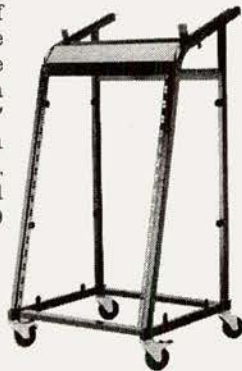

And then there's mixer stands, keyboard stands, desktop racks, music stands, all with the same legendary design integrity & build quality you've come to expect from K&M's microphone, speaker & lighting stands. Call us now for the full story.

trc

The Resource Corporation
6 King Street Blackburn Vic 3130
tel: (03) 9877 8233
fax: (03) 9877 8244
email: sales@trc.com.au

Elegant Efficiency

4065 Miniature
Microphone Headband
Available in black and
teige

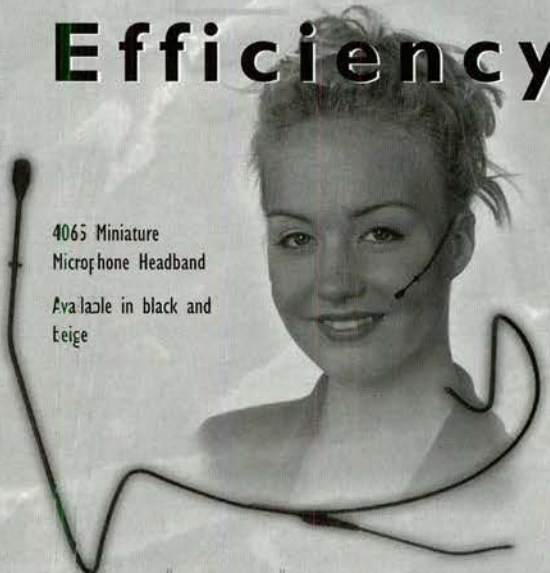

STUDIO
SUPPLIES
PTY. LTD.

5 Myrtle Street,
Crows Nest,
NSW 2165
Tel: 02 9957-5389
Fax: 02 9922-2043
Email: leonhart@ozama.com.au
ACN 103184502

Series 4000 Microphones
from DPA



Australia Day 2000 at Darling Harbour

by David Mansfield

The Darling Harbour Authority again produced a marvel of logistics and patience requirements for Australia Day this year. Last year the sound and lighting systems were spread out over about 900m. This year, to make it simple, everyone was put on a barge in the centre of the harbour – that is sound, lighting, screens, staging, rigging, sails and fireworks all in a 40 x 12m space.

From the start the worst potential problems were obvious. Once the barge was in Darling Harbour, nothing heavy was moved on to or off the barge. Secondly, rain became an issue.

As the control room was in the Convention Centre's "Skyline 2" room, getting a data, sound and vision feed to the barge was done with a carefully laid loom on the bed of the harbour. I must give thanks to The PA People for the use of three lines on their multicore for lighting data! The depth in the harbour was about 6m and a diving inspection was made by Tiny Good of Showtech Rigging for potential snags and damage.

Atlas Copco supplied power by way of four generators. These were lifted onto the barge from the loading area at Woolwich Naval Base - one each for lighting, sound, screens and a spare. Careful selection of generator size was required to ensure a suitable sized crane was ordered for loading.

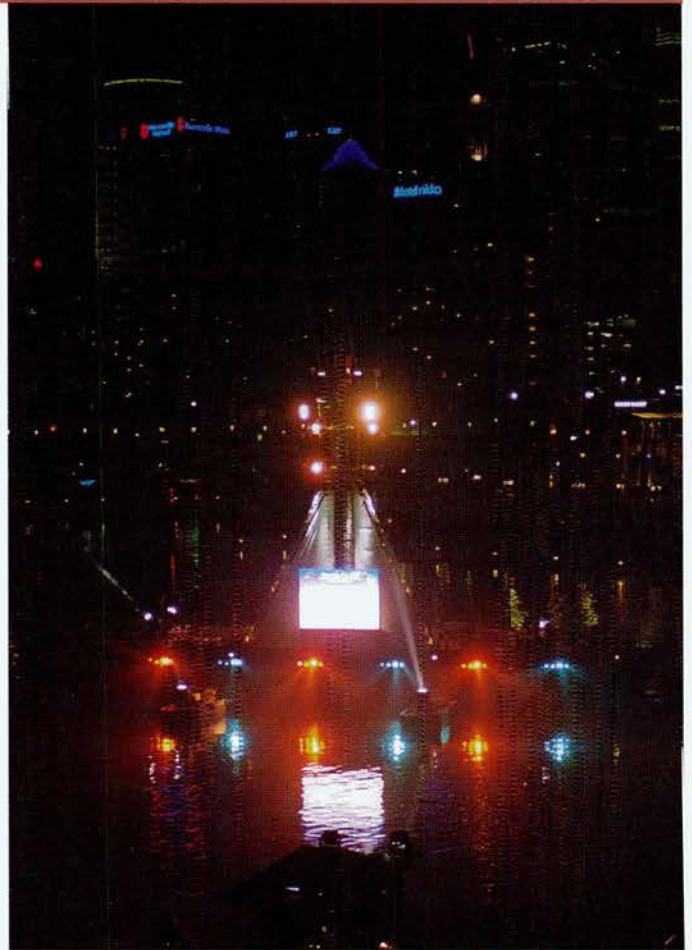

Photos courtesy of The PA People

Staging CAN'T get any easier than this...

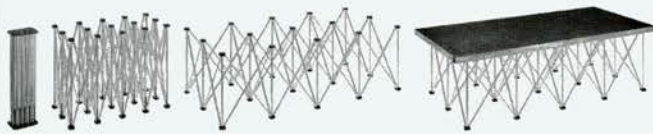

2m² of staging set up in 30 seconds by one person.
Sound good? Then also consider these points:

- Lightweight – one 60cm tall leg section weighs only 5kg
- Strong – will support 1000kg per m²
- Fast & easy to set up – the leg section can be set up with one hand!
- Versatile – multiple heights let you build steps, multi-level staging, in fact you are only limited by your imagination!

SC Systems - distributed in Australia by:

trc The Resource Corporation Pty Ltd
tel: (03) 9877 8233
fax: (03) 9877 8244
email: sales@trc.com.au



The Speaker Hospital

451 - 455 Liverpool Road
Ashfield NSW 2131

Phone: (02) 97971800 Fax: (02) 97971600

We are Sydney's largest repairer of speakers both domestic and professional having been established for over 12 years.

Service Highlights:

- * Factory Authorized Service of Most Major Brands.
- * Speaker Re-Edging (replacement of deteriorated foam surrounds).
- * Speaker Re-coning (replacement of all parts - cone, voice-coil, spider, gasket, dome, etc).
- * Speaker Magnet Realignment and Recharging.
- * 1 Year Warranty on All Repairs.
- * Shipping Available to anywhere in Australia.
- * We Accept All Major Credit Cards (Visa, Mastercard, American Express).
- * Free Estimates.

Music Box - Doing it Better

Service * Sales * Driveway Hire * AV Production * Staging * Draping

The crane was also needed for construction of the main feature of the production - a 20m high crane tower erected by ESS Rigging. So that the tower wouldn't sway in the breeze, Salken Engineering installed three very heavy duty rigging points to the floor of the barge. There were turnbuckles as thick as your arm and bow shackles that were almost a two-hand lift to secure the main structure in place. (...I must be a closet rigger....)

Atop this was the sound system and several of Chameleon's Griven Imperial searchlights. Running out from the centre, at 120deg from each other, were three triangular sails. This gave the moving lights something to register on other than just the fireworks smoke.

Fireworks were by Howard & Sons and the 3 tonnes of them made the deck look very busy- and that was before the show even started. Post-show, the deck was a scene of abject destruction. The smoke was ideal for the searchlights on the barge deck.

All this was envisaged by Andrew and Rosie Walsh from Accolade Events and managed by Andrew White from the Darling Harbour Authority.

Some of the issues that had to be planned for were the moving of a 20m structure through the Pyrmont Bridge and monorail, the barge had to pass through those obstacles before 5am on the way in and on the way out. Refuelling of the generators had to be organised "at anchor". A suitable bump in and out location area had to be found with the space and weigh capacity for a large crane, semi trailers, various other trucks and crew parking, ie Woolwich Naval Base.

Once the main barge was long gone three baby barges, each about 2 x 4m, were loaded at Woolwich with search lights and

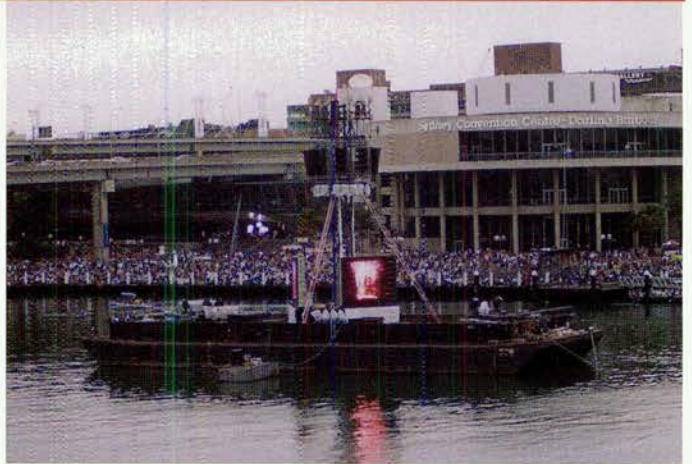

fireworks, to then be moved to Darling Harbour and placed around the main barge in a satellite manner.

There are a few matters that can be chalked up to experience. For one a barge is water proof, it doesn't let water in - or out. The rain pooled beautifully and provided a suitably challenging water trap to test the integrity of many shoe/boot types. Then there was the point that an earth-moving barge will, more than likely, have some residual dirt in it. That was taken care of by the aforementioned rain with the dirt miraculously replaced by mud. It didn't affect the show but it made bump out interesting.

The rain didn't prove to be an issue however, everyone was prepared for it with tarps, sheets of ply and various other water shedding materials.

Access to and from the barge once moored in Darling Harbour

continued page 79

Amphenol

Connecting People with Technology



EP / AP Series



SL61 Series



ACP Series



AC Series



Audio Connectors

Amphenol's Audio Connector range is available in a variety of styles including IDC and Solder Connections. For a cost effective solution to your Audio Connector requirements contact Amphenol now.

Amphenol

Amphenol Australia Pty Ltd
Head Office

2 Fiveways Boulevard, Keysborough Vic, 3173 Australia
Phone: +613 8796 8888 Fax: +613 8796 8801
Toll Free: 1800 674 569
Web: www.amphenol.com.au
Email: info@amphenol.com.au



"Awesome cable retention... by Amphenol"

Utopia Now in Hong Kong

Located in the heart of Hong Kong's famous 'Fragrant Harbour' is the spectacular Hong Kong Convention and Exhibition Centre. This was the setting for Hong Kong's pre-eminent Millennium Gala 'Utopia Now' presented by The Hong Kong Cancer Fund and Richard Li's Pacific Century Cyberworks Group to ring in the new Millennium. *Utopia Now*, as befits the centrepiece of Hong Kong's largest venue of its kind, was conceived on a bold and imaginative scale.

This Millennium experience was a 12 hour show of theatre-meets-circus blend of aerial acts, dancers, automated lighting and entertainers, the highlight of which was a 90 minute performance by the diva Whitney Houston. Opening for Whitney, was All for One and Sister Sledge with a line up of international DJ's and a variety of local acts keeping the party rolling until sunrise.

Winky Productions Ltd was contracted to handle sound production for this immense multi-faceted Millennium experience which was televised to 240 countries worldwide.

"It was a monumental task and the logistics of doing a show of this scale at the eleventh hour was enormous," said Wayne Grosser, Winky's Australian born Managing Director. "We provided concert sound for a crowd of 2000 people in the Grand Hall and the



Grand Foyer of the HKCEC. There were several changeovers between acts, all of which were well organised and handled efficiently by our team. We used our Clair Bros Audio System with the first Midas Heritage 3000 mixing console to be used in Hong Kong. It worked like a dream and Whitney's FOH engineer George E. Strakis was very pleased with its operation."

The design consisted of flying two main arrays each consisting of twelve Clair Bros R4 III's either side of the stage. Clair Bros ML 18 subwoofers and Clair Bros P2's were placed on the floor in front of the stage (left, centre and right) acting as sublow cabinets and nearfills. The system also consisted of eight Clair Bros P2's biamped for delay area's. FOH mixing consoles consisted of the one Midas Heritage 3000 as well as a Yamaha PM4000 with a total of 80 inputs returning from the stage. For processing we use a combination of DBX, Drawmer, BSS gates and compressors. Effects

AON Risk Services

AUSTRALIA LIMITED
ACN 000 434 720

presents

Entertainment Protection Plus

INSURANCE

FOR ALL YOUR ENTERTAINMENT RISKS

- Equipment
- Travel
- Non appearance
- Cancellation or abandonment
- Public liability
- Personal accident
- Vehicles
- Workers' Compensation

Call Ken Killen or Ian Stack
 TOLL FREE 1800 806 584
 for free quotations & advice

Level 27, AON Tower, 201 Kent Street, SYDNEY, 2000 Tel (02) 9253 7000

a microphone cable for every application...



02N6
"on the road" tough double jacket copper screen high flex 6mm OD



D2N6S2
high performance AES/EBJ 110ohm double screen 6mm OD

eurocable

cables for the new millennium



04N6S2
starquad style double jacket double screen 6mm OD



02N4.5
designed for TT bentam 4.5mm CD



02N3R
high flex designed for patch cables & rack wiring low profile 3.7mm OD



02N2A
very low profile foil screen install cable 2.7mm CD

trc

The Resource Corporation
 6 King Street Blackburn Vic 3130
 tel: (03) 9877 8233
 fax: (03) 9877 8244
 email: sales@trc.com.au



processors consisted of Lexicon, Yamaha and Roland units and playback included three Sony CD/MD players and one Fostex DAT recorder.

After flying the main PA to accommodate all the requirements for international stars and local acts, plus dance routines and performances all on the same stage, the most challenging aspect was to design the monitor system," said Wayne. "We used Clair Bros 12AM's and the wedges as floor monitors. Drum fill consisted of amplified Clair Bros 12AM plus an ML18 system and Clair Bros R4's were used for sidefill. Monitor consoles consisted of one Midas XL3 and a Yamaha PM4000M. Processing included a Lexicon PCM80, Yamaha REV5, Klark Teknik DN360 EQ's, DEX compressors Drawmer gates. Everything was powered by Clair Bros custom amplifiers; FOH - CBA 400C, CBA 2000HV and monitors - CBA 2000Q, CBA 2000HV."

Australia Day 2000 at Darling Harbour

continued from page 77

became a time consuming exercise but between the resources of the Darling Harbour Authority and Adam Huie from Banks Marine every obstacle was surmounted with minimum concern.

It does make me wonder what's on the boil for next year though.

All in all, cooperation between the various contractors made a job that could have been an absolute nightmare a veritable pleasure to be involved in. Of course the Sunday arvo BBQ overlooking the harbour from the shade of the Naval Base was hard work and could have ended in tears if the beer hadn't been carefully issued out and judiciously consumed.

David Mansfield is a Lighting Technician and Electrician who was contracted by Chameleon to work at this event. Sound and communication was provided by The PA People.



ENTECH CHECKLIST

1. Go to ARX stand and check out all the new stuff!
2. Go Home

At Entech 2000 we'll be releasing some great new products that should be on everyone's 'must see' list:

1. The e-pre computer based mic preamp

This unique and affordable tool was the surprise hit of the recent NAMM show, and puts high quality hard disk recording into everyone's hands

2. The MIX 8 - a stereo 8 into 2 line mixer. XLR, jack and RCA (phono) inputs and Balanced XLR outputs in 1 RU.

3. The ZA range of multi channel power amplifiers: ZA 400 four channel, ZA600 5 x channel, ZA800 eight channel, and the ZA5:1 surround sound amplifier, with a 250 watt Sub channel!

4. The complete range of the ARX SPL series of self powered speaker systems. SPL 10, SPL 12 (as reviewed in Connections last month), and the SPL 18 sub. Grab this opportunity to come along and see for yourself what all the good vibes are about.

5. The Climate 2 and Climate 6 weatherproof installation speakers. as used in the new Melbourne Aquarium and the UK Millennium Dome!

6. The new DI-Plus and DI-Plus 2 direct boxes

And of course all your other favorite ARX products, with ARX people on hand to answer your questions.

See you there!

ARX Systems P/L

Phone (03) 9555 7859 Fax (03) 9555 6747

Email: info@arx.com.au

Mail: PO Box 15, Cheltenham, Vic 3192



File Edit View Go Bookmarks Options Directory Window Help

Location: <http://www.arx.com.au>



Photos: Nicole Morris

The Big Day Out

a recovering production manager describes the touring mammoth

Matt Doherty is the Production Manager for The Big Day Out, one of the world's largest touring festivals. He also owns the Sydney-based company Australian Event Services who provide staging, portable roadways and grass cover and, of course, he hires himself for the BDO!

"Yes, AES is the staging company for the BDO," said Matt who starts working full-time on the BDO from the previous October. Work on the festival starts well over a year ahead, BDO 2001 is well under way.

"The preliminary stuff is just sorting out the venues (although they tend to be the same every year) and which way the promoters want to go in regards to how many other stages, the line up, and the configuration of certain area like the Boiler Room. Once they've decided what they want, we begin working out how we're going to build it."



A very calm cool and collected Matt Doherty, Production Manager of BDO

The festival travels to six cities - Gold Coast Parklands, Sydney Showgrounds at Homebush, Melbourne Showgrounds, Adelaide Wayville Showgrounds, Perth Bassenjean Oval and Auckland Ericsson Stadium - and a plan has to worked out for each of them

For the second year running, the Sydney BDO was held at Homebush, a venue which Matt says you have to work hard at to achieve a good show.

"It's very hard to get a vibe in that sort of venue as it's basically just a large concrete block," he said. "Also with the Olympic Coordinating Authority on top of the RAS as your venue owners, you run into bureaucracy and red tape at every turn. It's not something you'd want to do on a yearly basis but I guess we hang in there because we know the Olympic thing will be gone in a year or so and it might settle down to a reasonable venue. They don't make it easy to work there."

Matt prefers a 'green field' venue as you get a blank canvas to work with so, in that respect, the Gold Coast is a good venue. However the Gold Coast is limited in size. Melbourne is a good venue as it is still in one of the old showgrounds, is large and has a good vibe to it.

This year in Melbourne there were nine stages on the BDO whereas most other cities had six or seven stages - main Stages 1 and 2, Stages 3 and 4, Boiler Room, Hot House and What Is Music.

Jands Productions were the audio and lighting contractor for Stages 1 and 2 (with Bytecraft supplying the Icons). Chameleon supplied the lighting for The Boiler Room and Golight the audio. The other stages were supplied by local companies in each city visited.

"Main stages 1 and 2 and the Boiler Room are designed from what the bands want because we've always aimed to produce their shows on them," said Matt. "Stage 3, to a lesser extent, we

continues over

Jenny Davidson from Moon Mother Productions atop her stage which will be at the ENTECH Carnivale with Dru and Jeremy.





Upgrade Your 600 MHz to 96 kHz

Introducing the world's first professional tube mic pre

with dbx's proprietary Type IV™ conversion using the latest high-end A/D converters and all standard. The 386 also features our own TSE™ technology, which preserves the qualities of analog so you can take your signal straight to your desktop without sacrificing warmth. And taking the signal straight to your digital work station also means you no longer have to buy a separate converter box or rely on your sound card converters.

So, what else have we packed into the 386? For starters it includes features you would demand from a high-end mic pre such as:

- +48V phantom power
- 235V tube plate voltage
- Phase invert switch, and low cut filtering
- Selectable sampling rates of 44.1 kHz, 48 kHz, 88.2 kHz, or 96 kHz
- Selectable dithering and noise shaping
- Separate analog and digital output controls
- 12 segment LED meter for monitoring your analog or digital levels
- Convenient front panel instrument input jack
- Rear Panel mic and line inputs and outputs, word clock sync input and output, and both AES/EBU and S/PDIF outputs

Visit www.dbxpro.com to find out how you can upgrade your home workstation to 96kHz.

TUBES + 24/96 DIGITAL: NOW You're getting warmer.

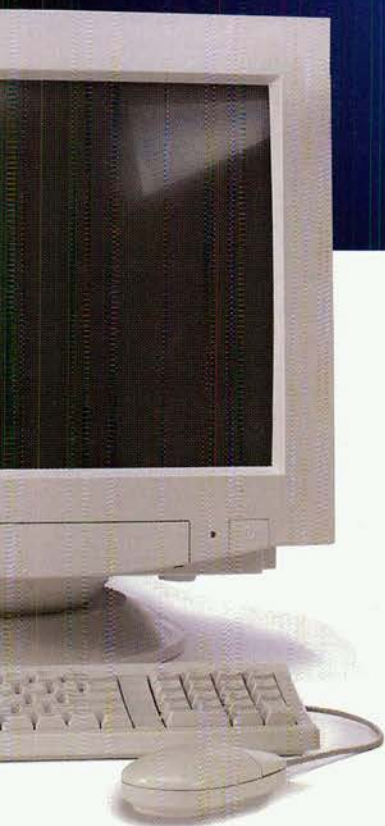

*Actual unit is 19" wide and will not fit in your computer drive bay.

dbx

PROFESSIONAL PRODUCTS

A Harman International Company

www.jancs.com.au

Tube Pre
386

The Big Day Out

continued from page 80

just take the final bands light show and the biggest bands sound specification and everyone runs through that. The other stages are usually just a festival system with a light show and sound system which everyone fits into, with the nature of the bands playing it's rare that you have problems.

"*Nine Inch Nails* had just under 12 tonnes of backline. They are very equipment heavy - they bring all their own house consoles, multicores, monitor console, wedges, power distribution. Their light show was very big too - they had Icons and Studio Colors. In contrast, the *Red Hot Chili Peppers* had a very cut down light show.

"*The Chemical Brothers* did the biggest production we've ever done in the Boiler Room. We used EAW boxes from Golight in Adelaide and there were six arrays - main, left and right of the stage; rear, left and right at the end of the house; and centre, left and right but it wasn't set up left and right. It was run through their own rack which did true distributed sound so you'd do centre left minus right, right minus left etc so you'd get some good sound effects. That was only for *The Chemical Brothers*, and was bypassed for the other acts.

"Their light show wasn't big but it was expensive. They had Barco 9400's rear projecting onto three screens that ran midstage and then on top of that, they'd have 16mm film projection running from FOH onto screens either side or above. Apparently it was a pretty amazing show."

Matt worked out that the light shows on the main stages cost an amazing amount of money because they've always aimed to produce the bands original production not just a festival rig. Yet the *Nine Inch Nails* only played a third of their show in true darkness.

"We've never had a touring festival rig which all the bands have to use," stated Matt. "That would be financially an efficient thing



Banning in the main room of the boiler room

to do especially as it's only the last two hours of the whole show that are in darkness, but the promoters want the show as if it was at the Entertainment Centre.

"It was quite a straightforward year, production wise, except for the Basement Jaxx in the Boiler Room. They had dancers and real time video, they normally tour with an outdoor LED screen at the rear of the stage. They were going to bring it this year but it wouldn't have worked in the Boiler Room. They're really into this real time video stuff where the guy is actually working on his images real time. They also used a video wall either side of the stage.

"There was a lot of video this year. I wouldn't mind making one of the shed-type rooms next year all video - all four walls made of giant video screens. We used a collection of screens this year. Dave Hawthorn from Exposure runs all the video for us and he sourced the screens."

Matt is used to strange requests at the BDO. This year *Antari Teenage Riot* requested that there'd be no smoking between the dressing rooms and the stage as one of the band members is pregnant. Matt replied that it was an outdoor show, to which they replied that they were aware but could they not be put in a dressing room next to a smoking room. They wanted it known that the band would refuse to walk through any clouds of smoke.

"I accepted that," said Matt wearily. "Then the next email from them requested that no connections, plugs or small junction boxes be placed on the front line of the stage whilst they are playing as the pregnant member is prone to vomiting during the show due to morning sickness! Wedges and other large objects were OK, because they were easy to clean. The tour manager apologised in advance and promised to clean up anything that happened. I don't think anything did.

"We didn't have any 'eccentrics' this year apart from *Primal Scream* who are just a bit weird. We didn't have a Courtney Love, Marilyn Manson or Ferry Farrell this year."

For such a large, touring production disaster incidents were very few. The fire alarm going off in the Boiler Room in Sydney during *The Chemical Brothers* act was one of the worst. Matt admits there were heated exchanges after that show.

"We've got to a point now with this festival where we're pushing the edge of the envelope with regards to size of the show so



Melinda Woods from Live Crewing her last gig before going off to have a baby.

Paul Moreland and Pete Gibbs from Gearhouse rigging the 5DV Digital Projector - a recent addition to the gearhouse inventory. There were 2 of these used in the Boiler Room's "Spill out room", displaying images approx 4-5 mtrs high.



continues over

Let us perform for you!



BIRKART FAIRS & EVENTS
Member of Birkart Globistics plc

60 offices worldwide



- Total World Tour Panning
- Airfreight, Seafreight & Air Charters
- Customs Specialists
- Forklift and Equipment Hire
- Door to Door Worldwide
- On-Site Handling & Storage
- Major Event Logistics
- Outside Broadcast Logistics
- Sound and Lighting Logistics
- New 48' Trucks in Australia
- Packing and Crating Services
- Express Courier Service

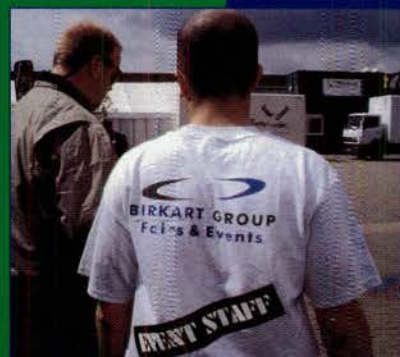

BIRKART FAIRS & EVENTS PTY. LTD.

MELBOURNE

28 Clarendon Street, Southbank 3006
Victoria Australia

Phone: 03 9696 3607 Fax: 03 9696 5927

Email: hocking@iaccess.com.au

SYDNEY

Level 2, Suite 4, Centrum Place
6-8 Crewe Place, Rosebery 2018
NSW Australia

Phone: 02 9313 8694 Fax: 02 9313 8695

Email: chris@birkart.com.au

*Check out our website
at www.birkartfairs.com*



**EXHIBITION
AND EVENT
Association
of Australia**

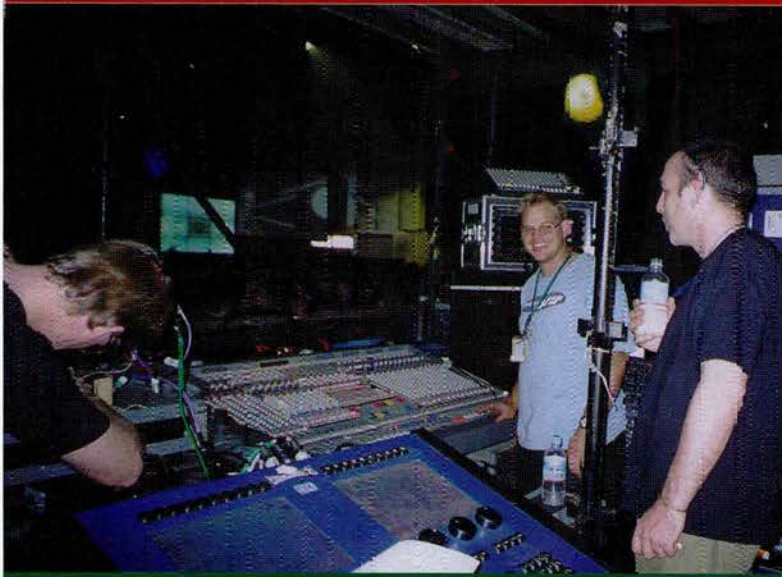

Chris Dennis from Colight Productions and John Hall with Pound System and Honeysmack.

The Big Day Out

continued from page 82

it's always fraught but we've never had any major problems."

The Big Day Out seems to be growing larger and larger by the year. In the space of two years they've gone from nine production trucks to seventeen.

"We have between 40,000 and 50,000 at any one show," said Matt. "Overseas where they have these sizes of crowds at festivals, there are rules and methods in place in regards to crowd control, and flow. In Australia we haven't got to this level with crowds in rock festival situations so we're basically writing the law on it. We're having to work out and go by international standards."

There was a touring production crew with the BDO of 31 with another 50 sound, lighting, video and technical crew hired in each city. This pretty much strapped the resources in most towns.

"My one real disaster this year was labour, especially in Sydney," said Matt. "There's just not enough labour to pull this show

in and out. On the night of Jan 26th we had a load out which required 122 loaders on top of the 80 production crew. That went to about 4am and then 8am, the same morning, we need to bump in at the Entertainment Centre, Hordern Pavilion and Metro for associated shows with the usual component of loaders. So that's 122 needed through the night and 60 the next day, on top of 80 production crew you've got to turn around with enough sleep. There aren't 200 loaders in Sydney and that's my biggest drama. The most experienced crewing company in Sydney, Lock and Load, can't fill more than 50 people and they pulled out of the BDO two months prior. That was a huge blow and the next crewing company in line, as far as we were concerned, was Live Crewing and they couldn't put more than 80 people in.

It's a problem we need to address, next year we're considering putting 40 loaders on a coach from Melbourne and putting them up for three days in Sydney."

When I asked Matt if the BDO was going to be bigger next year, he nearly fell off his chair laughing.

"It's the big question, what the heck are we going to do with this show?" he laughed. "Personally, I don't think any of the sites can get any bigger. One thing we've always kept our eye on with regards to crowds, is queue length and I think we're on the limit now. If anything, we need to consider pulling it back a little bit. I don't think there's enough production around to make the shows any bigger. In New Zealand we had crowds of 52,000 and used up all the available gear as well as taking a load in. The options are to either make it smaller and sold out every year or go into multiple days at the cities that require it, doing the same show each day.

"That means extending a two and a half week tour by another week and the costs involved in that would be a lot. It may not be economically viable to do. The BDO is already an enormous risk for the promoters. They do make decent money on it but not nearly as much as people think."

● Cat Forcer

The Next Generation In Rental Management Software



HIRE TRACK
Eclipse

- Multi Currency
- Multi Site
- Multi User

For Win95/98/2000/NT.



NAVIGATOR SYSTEMS
+44 (0) 7000 628797
info@navigator.co.uk
www.navigator.co.uk

Eclipse

- Job
- Hire
- Warehouse
- Equipment
- Diary
- Planner
- Multi-site
- Addons

LIVE



Photos: Mandy Jones

FOO FIGHTERS *taking it easy*

It's nice to see a band that values its crew. The Foo Fighters like their crew so much that they take them on tour even when they're not really needed. The Foo's lighting designer Mike Lamb admitted that all he's really done in Australia during the band's recent tour is play golf. Playing daylight sets at the Big Days Out and with only a couple of small club dates in Sydney and Melbourne, Mike has only had to deal with small lighting rigs, giving him all the more time to work on his handicap.

Mike explained that the band are on a *Queen* kick at the moment so his lighting designs have taken on that theatrical-rock look. And having just been announced as support band for the *Red Hot Chili Peppers'* US tour, Mike said the band is at a turning point with their on-stage image.

"We're all really psyched because we're going out with the *Chilli Peppers* so the band is really ready to take it up to the next level. They're at a changing point right now as to what direction they'll go in. But I think it's going to lean towards that whole seventies all-analogue-lights thing. It's really theatrical because when you see all those old videos, and that's what they're basing it on, it's all darkness with pools of light.

"We've been sitting around watching all the *Queen* videos and they always had a giant wall of lights behind them so they're into that right now.

"Usually down here we get an Echelon or something in that family. I kind of like the Echelon. I don't know the ins and outs of it, like I probably should, but I know how to programme and run it.

Mike likes rich colours for *Foo Fighters* shows. He relies on dark blues and reds but likes to cut through the darkness of those colours with correction filters 24E and 203.

"I'm into Lee 24E right now which is a fluorescent green colour like a super pale green and I think it's really cool. My room-mate Spike is also a lighting guy and he turned me onto it. He was like 'Dude you should try these green ones'. And when you get a lot of it, it's not really *Metallica* spooky because it's lighter than that, but it's got a really cool clean feel to it. I mix it

with 181 Congo and 125 Mauve. I like a lot of rich colours, like dark dark blues, standard reds, and mixed with that no colour stuff it just cuts through them.

"Mostly I really like that green because not many people use it, and let's face it, everything has already been done."

AUDIO

Scottish Monitor Engineer Ian Beveridge has worked with lead singer Dave Grohl since *Nirvana* days.

For the Hifi Bar, Ian said the band would easily be playing the kind of levels you would expect from an arena show.

"Normally what we do is carry a system of ten double 15" wedges and the side fills are usually Flashlight. We've got the drummer Taylor using the new Shure 700 series two way earpieces and they sound really good. It's helped Taylor a lot because the drumfill was so loud. I used to use two stacks of Floodlights for drum fill which is just crazy. In some places I would use four double 18s and all kinds of stuff and it just became horrible. And of course he would play with ear-plugs. It was just destroying the drum sound, so it's much more solid now, and much easier.

"We've also been trying out some new wedges by a company called Compact Monitor Systems which are an interesting design. They are a three way system with an amazingly good mid range, better than anything I've ever heard before so hopefully we're going to use them in the future."

Ian usually uses a Midas XL3 and FOH use an XL1200. After recently using the new Heritage console Ian said he would have liked one on this tour.

For microphones, Ian said the band have their favourites which are predominantly Audix and Shure.

"I really like Shure mics myself. I use a 52 in the kickdrum, there's a 91 in there (toc) and a D-drum trigger which we just started using recently.

"The vocal mics are Audix OM6s - they're kind of unstable and they don't react to water well at all, whereas a SM58 you can basically use as a hammer.

■ Mandy Jones



Ian Beveridge, Monitor Engineer



Free Classifieds

Only free if lodged by email, fax or post: email nic@conpub.com.au, fax: +61 2 9876-5715, Post to PO Box 439, EPPING NSW 2121 Australia. Display and paid classifieds: call Nicole, 1-800-635-514

Text: first 15 words free, then \$15 per 15 words or part

POSITIONS VACANT

ENTERTAINMENT POSITION - Casual. Crown Limited - Melbourne. Looking for diversity? Are you a reliable tram player who works well under pressure? Can you solve problems in a logical manner and follow through with a systematic approach? The successful applicant must have extensive experience in operating audio, lighting, staging components and all aspects of audio visuals for a corporate environment. This person would need to be well presented, punctual, be available to work at short notice and have own transport. Please forward your application to Human Resources, 8 Whitteman Street, Southbank VIC 3006.

GUJARIST wanted for legendary comedy - rock outfit. After their recent success on the Boys Are Back in Town tours, The Legendary Zarsoff Bros are back on the road. However, we are looking for a second lead/rhythm guitarist with vocal harmony ability to complete the line up. We are looking for a highly competent, mature musician/performer with that special sense of humour which has made us so infamous. Irreverence for the rock stardom construct would assist you in the Zarsoff experience, as would some knowledge of the band's history and performance values. You must be dedicated enough to put in some unpaid rehearsal, songwriting and recording time so that we are well prepared for a new album and live shows to promote it. As well as new material we will be playing a selection of songs from our previous repertoire, so some initial hard work is the order of the day, after which you will be ordered to enjoy yourself immensely. If you think you are who we are looking for, ring Izzy on 0414 627125 (or drop some contact details at zarsoffbros@netscape.net) and we'll arrange a blow.

SERVICE TECHNICIAN, Senior Position. One of Australia's leading Audio-Visual Contracting Companies require a Senior Technician to provide service support on all of our Installations. Must be available to do after hours call-outs. The successful applicant would need to have a background in Audio, Video and Lighting. A tertiary qualification would be a must, along with proven practical experience. Excellent remuneration, conditions

and a fully maintained company vehicle will be offered to the successful applicant. Please forward Resumes to the attention. Senior Service Technician. Total Concept Projects (Aust.) Pty. Ltd. PO Box 6405, Silverwater NSW 2128.

SHELLHARBOUR Workers' Club Ltd requires a permanent part-time technician to maintain all facets of the in-house facilities. Reporting to the Entertainment Manager you will need to have three years experience in a similar position, have broad-based knowledge of Audio, lighting and video and a healthy 'can-do' approach. Please call the Human Resources Manager for a copy of the selection criteria on (02) 4296 7155 or email

shayneleslie@ozemail.com.au. Applications close Friday 17th March 2000.

STOLEN

FROM outside Sound Solution in South Melbourne, Vic during the evening of the 11th Jan 2000 in a Mitsubishi Truck. The truck contained EHT PMH3 passive 12" + 2" mid hi speakers, EHT PSB2 dual 15" subwoofers, Sound Solution dual 18" and 15" subwoofers, Sound Solution passive 2x12" + 1" wedges and 2x15" + 1" drumfill. EHT 4000P amplifiers in rack and roadcase. Sound Solution 28L600 equaliser/amplifiers in rack and roadcase. Soundcraft 400B 24 channel mixing console in

Audio Visual, PA and Lighting Suppliers

Expressions of Interest

Project Scope: Consultation, design, installation and commissioning with ongoing technical support.

System: An integrated industry standard package delivering exceptional clarity in the presentation of: Contemporary music; Theatrical productions; Speech.

Venue: Medium Size, Multipurpose; Under construction.

Supplier capability: Proven record in cost competitive supply of high quality products with exceptional service; Technical expertise.

Tender process participation: Provide supporting information i.e. capability statements, 3rd party recommendations.

Applications close Friday 31st March 2000.

Send to: The Technical Operations Director, PO Box 377, Toukley NSW 2259.

AUDIO SALES DEVELOPMENT MANAGER

C.M.I., one of Australia's fastest growing Audio distributors, is seeking an experienced sales professional. You will have national responsibility for audio sales with a special focus on developing and expanding our client base. A solid sales background in live sound and/or contracting together with great communication skills and a high level of self-motivation is essential.

Please send resume to: CMI Po Box 499 Altona Vic 3025. Fax (03) 9315 2115. For further details phone Peter Trojkovic on (03) 93152244 or 0413 055 537.



Technical Director, Senior AV Operators and AV Operators

Looking for the chance to build a career in event staging? Hoping that you won't be delivering boxes forever? Join a company whose growth gives remarkable opportunities to bright people prepared to work hard.

Staging Connections needs experienced and capable technicians for a wide variety of positions. You will be skilled in data display, video, audio and lighting. You will have strong team skills, and the flexibility to work long hours when required. You will have the presentation and personal skills to work in a five-star corporate environment.

Staging Connections is strongly committed to developing the skills of its employees, and the long term prospects for good people are almost unlimited.

If your one of them, apply in writing to:
Leanne Isabella, Locked Bag 10, Drummoyne NSW 2047.



BYTECRAFT®

SALES EXECUTIVE

- Can you sell lighting, hire or events?
- Salary Circa \$50k plus company vehicle
- Entertainment Industry/Special Events

Bytecraft is an Australian success story specialising in the design, manufacture and maintenance of high quality "state of the art" electronic control systems. The company's main thrust is in the theatre, entertainment and leisure industries. In addition, we also provide a service, maintenance and rental market for entertainment lighting.

With projects already scheduled for the year 2000 we are assured of ongoing success. Sustained growth has created the need to appoint a successful, experienced Sales Executive to our proven New South Wales sales team.

Your experience should include:

- A strong background in entertainment lighting and an understanding of lighting effects areas applicable to theatre, television and corporate events;
- A demonstrable track record in sales and marketing;
- Capability of presentations at the top level;
- Ability to multi-task and work well in a team environment.

Interested - then send a fax to:

Julie Grant (03) 9586.4523 or send an e-mail to jgrant@bytecraft.com.au by close of business on Friday 31st March 2000.

roadcase. Allen and Heath GL2000 16 channel mixing console in roadcase. 17 unit Fx rack & roadcase ("Little River Band" stencils). Sound Solution TQ128B equalisers, Yamaha REV7 multi fx, Digitech DSP256 multi fx, Roland SDE1000 delay, Alesis 3630 stereo compressors, ARX sixgate. Sherwood Cassette

player. Stands case with tray for multicore and multicore. Tall boom, tall straight and short boom stands. Roadcase containing mic leads and EP8 and XLR speaker cables. Case for Microphones containing Shure SM58, SM57 and Beyer M88 Mic; plus Sound Solutions DI's. The truck has since been recovered, how-

ever the gear is still missing. Should you have any information regarding the gear or the incident, please contact Tony at Sound Solution on (03) 9686 4755.

STUDIO FOR HIRE

FAIRLIGHT MFX Studios. Friendly support. Easy free parking. Good indie sound solution. Call John (02) 9880 7081.

PROFESSIONAL 24track analogue studio, 16track non-linear digital, mastering, non-linear video. Liverpool Campbelltown district. Phone: (02) 9605 1203. Email: tribal@zip.com.au.

STUDIO FOR SALE

RECORDING STUDIO facility for sale in Sydney. Includes purchase of building which contains control room, studio, office space, kitchen area and 3 other general purpose rooms. Has all wiring in place. Price does not include equipment except for a NEC Ranger phone system. Located close to rail station and shops and is in prime development area. Price range \$270,000.00 to \$310,000.00. Call Ross (02) 9587 7711.

WANTED

1 JBL/UREI Model 7110 compressor/limiter. Please contact Richard or Adrian at McLean Audio Services (03) 9429 5381

FOR SALE

2 DYNALITE 12 X 2.4KW Production Dimmers, front breakers, rear outlets, recently serviced, excellent condition, \$1,000.00 each \$1,900.00 for both. Phone (02) 9311 1197.

AAFTER a certain piece of gear or have some to sell. Call Neil @ Cannon Sound on (02) 9948 4440.

ACCESSORIES/MICROPHONES. Flexible mic clips \$3 for \$20. Flexible radio mic clips \$15 each. 10 metre mic leads \$25. Proel mic stands \$70. Cannon Sound (02) 9948 4440 or sales@cannonsound.com.au

AKG D-112 Classic bass drum mic \$300.00 (02) 9153 9988.

AKG D202 Mics, Two \$250.00 each. Phone (08) 9339 4791.

ALLEN & HEATH GL2000, with roadcase, excellent condition, 1 band, 1 owner \$3,800.00 ono. Audio Advantage (07) 3300 4996, 0411 481 735.

AMPLIFIERS. Jands 920 500w + 500w. Delivered to your door Australia-wide \$650 each. Quantity in stock, get 'em qu ck. See us on the net @ www.cannonsound.com.au.

Cannon Sound (02) 9948 4440. ARRIVED! Just in! P.Audio 800 watt R.M.S. 18" speakers. Huge handling power at an unbelievable price. Come and kick the tyres at Stand K12 Entech 2000 or call Cannon Sound for specs and price (02) 9948 4440.

ATARI MX70 16 Track 1" with remote. Just fully serviced, in good condition \$5500. Have a look at it at www.cannonsound.com.au or call (02) 9948 4440.

AUDIO DESIGN VOCAL STRESSOR Vintage British vocal processor recapped and reconditioned MIXMASTERS (08) 8278 8506

AUDIO LOGIC 440 Quad Noise Gate \$400. Cannon Sound (02) 9948 4440 or sales@cannonsound.com.au

AUSTRALIAN MONITOR AM1600 Amplifier \$1800. Cannon Sound (02) 9948 4440.

AVALON. No compromise pro audio, all models in stock totally affordable. MIXMASTERS (08) 8278 8506 mixm@senet.com.au

BSS MCS 200 Crossovers (4). Stereo 3 way + mono sub out, limiting and phase correction \$1500 each. Cannon Sound (02) 9948 4440.

CARVER PM1200 Amplifier 2RU and really light (save your back) \$1200 each. Cannon Sound (02) 9948 4440.

COEMAR Bello effect with lamp, good working condition \$1,200.00. Black Express (02) 9559 4363

COLLECTABLES.....Altec 515 15" speakers \$2000 the pair.

Goodmans 15" Speakers. Set of 4 for \$2000. See them at www.cannonsound.com.au or phone (02) 9948 4440.

CONSOLES from the very large, to the very small SHRAPE www.ozemail.com.au/~shrape (08) 8278 8506

DAT Portable Panasonic professional SV-255 XLR inputs like new with service manual \$1,200.00. Contact Juan Ph: (02) 4325 5885.

DBX-163, Compressors, Studio use only \$190.00each. Jeff (02) 9153 9988.

DIAPHRAGMS, DIAPHRAGMS, From \$70, high quality replacement diaphragms to suit many popular 1", 1+1/2" and 2" drivers including: Altec, Acoustician, Coral, Radian, RCF, P.A.S., P.Audio, Toa, Zomax and around 20 different JBL models incl. JBL 2416 [MR Series and EONs], 2402, 2404, 2405, 2412 [TR Series], 2440, 2441, 2445, 2446, 2447, 2450, JBL LE85, 2470, 2421, 2420, 2425, 2426 etc)

We can deliver next day anywhere in Australia. Cannon Sound (02) 99484440 www.cannonsound.com.au.

ETONE 2122 Speakers, 200 watts, \$850.00 per pair. Black Express (02) 9559 4363.

EV 2x15" horn loaded subs, Altec design cabinet, \$1,000.00 each. Black Express (02) 9559 4363.

EV S1500 15" and horn cabinets. Out of an install \$1200 a pair. EV FM12C dual concentric monitor \$500 (1 only). Cannon Sound (02) 9948 4440.



BRISBANE CONVENTION & EXHIBITION CENTRE

The award winning Brisbane Convention & Exhibition Centre offers world-class meeting and exhibition facilities and hosts more than 500 international, national and local events each year.

Applications are invited from motivated and enthusiastic individuals who enjoy working in a team environment, are totally committed to providing outstanding service, and who have a desire to succeed in the hospitality industry. The following vacancies exist

Audio Visual and Production Services Department

ASSISTANT PRODUCTION MANAGER

Our busy Audio Visual and Production Services Department is seeking a highly experienced Assistant Production Manager to plan and co-ordinate the daily operational tasks of the department.

You will require highly developed organisational and administrative skills and an ability to cope with the unexpected. Experience in a similar venue, production company or theatre environment, is essential.

Abilities in equipment and human resource scheduling, co-ordination and management, and excellent client liaison skills are essential. Demonstrated recent experience in a variety of audio, lighting, video, projection and rigging services combined with an understanding of WPHS legislation and accurate documentation, are also pre-requisites for this position.

If you would like to be part of Brisbane's most exciting meeting venue, then please APPLY IN WRITING ONLY to:

Human Resources Department
Brisbane Convention and Exhibition Centre
PO Box 3869
South Brisbane Qld 4101

Applications close 5pm, Friday 17 March 2000.

BCEC is a smoke free work environment and an equal opportunity employer

THE AUDIO DEPT.

Wireless Microphone Specialists. 20 years experience. Large inventory of Sony UHF systems, Shure UHF and VHF systems, and now Garwood In-Ear monitors.

Short or long term hire for all applications, sales and full service.

Authorised Sony Wireless Service Centre.

Call for a quote.
(03) 9415 1868.

Drapes and Stages

from **Staging Rentals**

"Your complete staging service"

Big range Top quality On time
Friendly, professional advice

Ph: (02) 9519 6300

Fax: (02) 9519 6489

1 Pyrmont Bridge Road
Camperdown NSW 2050
mail@stagingrentals.com.au
www.stagingrentals.com.au



SOUND & LIGHTING

Hire, Design, Sales
Installations, Service

47 Auburn Street, Wollongong

Ph: (02) 4229 6010

"I've never seen
such brilliant
colours"

This is an authentic statement from one of our customers interviewed at 6am on site at the Happy Valley full moon experimental music festival.

In the dark? Dial up
www.electricsunshine.com.au for light.

EV Tapco 100M Entertainer. 10 channel powered mixer \$800. Cannon Sound (02) 9948 4440.

EV TL 2-way 15" + horn bins \$800 the pair. Cannon Sound (02) 9948 4440.

EX-HIRE Stock sale. Goldenscan moving lights, Dynalite DMX dimmers, LEM12 Ch mixer, speakers & stands, Plus much more. Phone for a complete list (03) 9819 6912.

INTELLIGENT lights, NJD IQ250, 8 colours, 4 gobos, 4 + controller \$2,500.00. Black Express (02) 9559 4363.

JANDS 920 Amplifier perfect condition \$900.00. Contact Juan Ph: (02) 4325 5885.

JANDS AP30 speaker system - 8 cabinets in total - similar to Turbo TMS3's. Each loaded with 2 P.Audio P150/2226 15's (new), 2 JBL M110's on phase plugs and 2" P.Audio PA-D72 drivers (new) on a P.Audio 2' 60 degree flair (new). Warranty on all new components. \$11,000 includes delivery to any capital city in Australia. This system is a lot of sound for minimum outlay. Cannon Sound (02) 9948 4440.

JANDS SR-3000 Amplifier in 4 rack units in flightcase, top condition Contact Juan Ph: (02) 4325 5885.

JBL 2901A cabinets. Loaded with a JBL 2205 15" speaker and a JBL 1" on a T-strainer flare. \$1000 the pair. Cannon Sound (02) 9948 4440.

JBL AP25 cabinets. As new condition, JBL loaded. Suit Turbo TMS4 buyer. \$1500 the pair. Cannon Sound (02) 9948 4440.

JBL genuine new 1990 issue in the carton D16R2440 diaphragms. The best sounding diaphragms JBL ever released. Will suit 2440, 2441 and 375 drivers.....real hi-fi sounding.....\$300 each (4 only). Cannon Sound (02) 9948 4440.

JBL System 700 speakers, 15" & horn \$1,250.00 each. Black Express (02) 9559 4363.

JBL2226 (8 ohm) 15" Speakers in excellent as new condition - 1 pair only - \$450 each. See us on the net @ www.cannonsound.com.au. Cannon Sound (02) 9948 4440.

JOEMEER British audio at its best. All models in stock for trial

SHRAPE (08) 8278 8506 www.ozemail.com.au/~shrape

LASER System with controller, 52mw, red, \$995.00. Black Express Light (02) 9559 4363

LEXICON PCM-41 Delay MIXMASTERS (08) 8278 8506 mixm@senet.com.au

MACKIE FR-M1400 Amplifier in factory carton used only 500 hours, with factory warranty. Only 2 available. Contact Juan Ph: (02) 4325 5885.

MARTIN 2518 DMX controller, bought, installed but never needed. \$450. Brad 0142647785 or BraddonC@aol.com.

MARTIN 518 (X8) Moving Lights Plus Martin 3032 Computer all only 6 months old as new condition, \$15,000.00 ono the lot. Ph: (08) 8221 5222.

MARTIN Pro400's inc lamps, standard and wide lenses, \$950.00 each, Black Express (02) 9559 4363.

MARTIN Pro518 Roboscans including lamps, \$1,300.00 each. Black Express (02) 9559 4363.

MICROPHONES. AKG, Beyer, Seinheiser, etc. Pre-owned in

stock. SHRAPE (08) 8278 8506 www.ozemail.com.au/~shrape

MSR 24TR Tascam - 1 inch, Studer A80, 8 track, 1 inch. GSP2120 with foot pedal. Tascam 3030 1/4 in. (02) 4353 2429.

NEUMANN U87, U89, Mixmasters (08) 8278 8506. mixm@senet.com.au

P.AUDIO Professional Loudspeaker Components. 'Professional Sound for Professional People'. New 10", 12", 15", 18" Speakers. 1 and 2" Hi Frequency Drivers. Flares and Diaphragms. Quality at an affordable price. With most things in this world you only get what you pay for. With P.Audio you get much more.....See the full range live at Entech 2000 Stand K12, on the Net at www.paudiosystem.com, or call

Cannon Sound (02) 9948 4440 or sales@cannonsound.com.au for a catalogue.

PEAVEY Impulse 200P biamped speakers, 1x12" + horn, 300

watts, \$1,900.00 for both. Black Express (02) 9559 4363

PRINCE Scan 575 moving lights x 4 + controller, \$5,000.00. Black Express (02) 9559 4363.

Graftons Lighting & Sound

Professional Equipment & Service
**Hire, Sales, Installs
Production & Design**

6/890 Bourke St, Waterloo NSW 2017
Tel: (02) 9698 7777 Fax: (02) 9698 9999

Lighting: graftons@idx.com.au
Sound: info@productionservices.com.au
Sound: www.productionservices.com.au

Wanna know more about AV?

Effective Audio-Visual
3rd edition. Robert Simpson.

A user's handbook for anyone who needs to know more about audio-visual equipment and techniques. Includes techniques such as overhead projection, slide-tape, film, multi-image, video and the increasing use of the computer.



\$80.00 plus p&h **Connections** Shop 1800-635-514

The gobo Factory

GLASS STAINLESS STEEL

*Custom-made and Catalogue Range
Customised Message & Theme Sets*

Quality, Service and Competitive prices

Ph: 61 3 5439 3770 Fax: 61 3 5439 3601
Email: gobos@netcon.net.au
Website: www.gobo.com.au

ACOUSTICS

• Manufacturers of high performance modular acoustic panels • Room design • Acoustic analysis

PH: (08) 8346 4199

**ROADCASES
for
PROFESSIONALS**

de Sine
ROADCASES

STANDARD RANGE & CUSTOM MANUFACTURE
19" RACK CASES AND SYSTEMS. LIGHTWEIGHT,
STANDARD AND HEAVY DUTY. LIMITED LIFETIME
WARRANTY APPLIES TO ALL CASES

CALL US FOR A CATALOGUE & PRICE LIST

PH: 07 3899 2971 FAX: 07 3899 0155
Email: desine@powerup.com.au

Technicality

Specialists in
AUDIO VISUAL SERVICE & REPAIR

- Video/Data Projectors
- P.A. Systems
- Video Cameras
- Broadcast Equipment

- Digital Audio & Video
- Studio Equipment
- Home Theatre
- Stage Equipment

Ph: (03) 9737 0007
technicality@service.mel.net

**Professional Audio and Lighting
Sales, Service and Production**

**1 Mary Parade,
Rydalmere NSW 2115**

Ph: +61 2 9638-0302

Fax: +61 2 9638-0331

All New!

WIGGLY STAND®

Ultra Stable, compact,
one person operation floor stand
for large or small
Moving Mirror luminaires.
Available in 2 sizes.
Info sheet & price list available now:

PR Lighting, SA
+61 (0)8 8391 3233 (Ph/Fax)
E-mail: prlx@olis.net.au

PRO AUDIO USED for full list email mixm@senet.com.au, or www.ozemail.com.au/~shrape
PRO AUDIO: Buy, sell, trade. What y' got on that cupboard? press the button, turn it up! mixm@senet.com.au or

www.ozemail.com.au/~shrape
SHRAPE. (08) 8278 8506
REEL to Reel 1/4 inch caps, brand new, unopened boxes Agfa 5" reels \$2.00 each J418 623 847

RENKUS HEINZ SD 1800-8 Drivers & Flares (pair) \$400. Cannon Sound (02) 9948 4440.
RNC 1773 "Really Nice Compressor" Unbelievable. Available NOW. MIXMASTERS (08) 8278 8506 mixm@senet.com.au

ROADCASE to suit Otari 24 track recorder or similar \$500. Cannon Sound (02) 9948 4440.
ROCKARD Coatings for your PA and roadcases - the true industry standard. 1 litre \$30, 2 litre \$45, 4 litres \$72, 18 litres \$225.

Prices include delivery anywhere in Australia. For more info go to www.cannonsound.com.au. Cannon Sound (02) 9948 4440.
SHERMAN FILTER BANK in stock. SHRAPE (08) 8278 8506 www.ozemail.com.au/~shrape
SONY / IBANEZ SDR-1000 Serious Stereo Reverb/delay \$900 MIXMASTERS (08) 8278 8506 mixm@senet.com.au
SONY DTX-10 Car DAT Player, AM/FM Radio/CD Changer

\$800.00. Phone: Kane 0419 570 660, (02) 9467 4579.

SONY PCM 2700A DAT Digital recorder \$900.00 o.n.o. 0418 623 847.

SOUNDCRAFT 2400 serious recording console \$8,000 reduced MIXMASTERS (08) 8278 8506.

SOUNDCRAFT 762/24B 24 track analog recorder, perfect order. Best offer Ph. (07) 3878 4707

SOUNDTRACS MRX 32/8/2 in roadcase. 24 mono and 8 stereo channels \$6000. Cannon Sound (02) 9948 4440.

SPEAKER Systems Clearance! Everything from Duds to Large scale concert events! Ring for full list (02) 9799 7219.

SPL Classic Vitalizer/As new \$1,100.00. Ph (07) 3831 8588.

STUDIO Due "Giant" moving yolks including lamps, excellent condition, \$1,400.00 each. Black Express (02) 9559 4363.

SUBS. Front loaded with P.Audio 18" \$400 each (4 in stock). Cannon Sound (02) 9948 4440.

TASCAM M-1016 mixer. 8 mic + 4 stereo line channels, 4 auxiliaries, 3-way EQ with sweep on mid, rack mount ears, in wooden case. Great condition \$650. Cannon Sound (02) 9948 4440.

TASCAM M216 Mixer 16 XLR/RCA Inputs. 4 bus like new with PE-40 4 channel parametric equaliser for studio or live. Contact Juan Ph: (02) 4325 5885.

UREI 1178 Classic compressor WALL brackets to take 12" + horn or 15" + horn. Steel. Out of installation. \$120 for set of 4. Cannon Sound (02) 9948 4440 or sales@cannonsound.com.au

YAMAHA REV 7 \$600 Mixmasters (08) 8278 8506

BRIAN McMAHON
TECHNICAL SERVICES
Melbourne 0402 11 5999
Studio Maintenance, Technical Support. Outboard Repairs. Design/Modifications
COMPREHENSIVE WORKSHOP

B. S. Sound PA Hire
3k PA with separate F/B, LX & crew. Driveway Vocal PA Systems & LX. Mics & components also available.
Contact Mark Barry for free quote
(03) 9531 1403 or 041 999 3966
www.bsound.com.au
mark@bsound.com.au

FOR
CUSTOM CASES
SPEAKER ENCLOSURES
TUFFA
CASES & CABINETS PTY LTD
Ph (02) 9153 9373 Fax (02) 9153 9329
Unit 5, 15 Lorraine Street Peakhurst 2210

GOBO
Greyscale Glass, Colour & Steel
Lighting by Design
First with the glass technology to OZ now standard in Martin 918 and Mac500.
Original designs & innovative ideas.
Tel: 0755 377 002 Sales@LBD.com.au
Fax: 0755 292 226 www.LBD.com.au

Staging ☆ Lighting ☆ Sound
For Concert Productions, Press Conferences, Launches, Corporate Seminars etc.
Office: (02) 9792 7770
Fax: (02) 9792 6660
Contact: Fred Ward
Mobile: 0418 212 431
Melinda Woods
Mobile: 0418 215 002



HirePoint98
Hire Software
For AV, Lighting & Audio Equipment rental & production, staging and business theatre.
SEE HIREPOINT 2000 AT ENTECH 2000
See integrated e-commerce for your business with HirePoint 2000.
It will exceed your expectations!
finalist - 1997 Small business show software awards
Download a demo from the web! www.hirep.com
Phone S.F Business Developments (03) 9761 2585,
HirePoint Software (02) 9824 1105, fax (02) 9824 0554

avi
Audio and Visual Innovations Australia Pty Ltd
Professional Audio & Lighting
Sales • Production • Installation
Clay Paky Miniscan HPE
Clay Paky Stagelight
Martin Pro400
Turbosound Hillight
Turbosound Floodlight
Excellent Cross Hire Rates to Trade
41 Brookes Street, Bowen Hills QLD 4006
Phone: (07) 3252 4022 Fax: (07) 3257 4950

ROSCO
DESIGNER SOFTWARE
ON CD-ROM
SOFTPLOT is Windows based for creating and maintaining design plots and paperwork Tax Free \$548.00
LIGHTSHOP is Windows based and provides photometric info. on more than 1500 fixtures Tax Free \$230.00
HORIZON is the free Windows based program that turns your PC into a lighting desk.
CALL YOUR ROSCO DEALER

TURNTABLE
4m diameter, 450mm (variable) height, capacity 3 tonne.
Power 2 x 0.37KW, Motors/40:1,
Reduction boxes source single phase 10 amp.
Variable speed, drives forward/reverse and timer switching.
Can be installed inside/outside on any surface.
Runs on inverted roller system with levelling jacks.
Phone (07) 5531 1966

Mastercut
GOBOS
• Custom made Stainless Steel and Glass Gobos
• Super fast turnarounds • Competitive prices
Telephone 07 5598 1200 Facsimile 07 5534 1891
Web Site www.mastercut.com.au



CATALOGUE Gobos
distributed by
Clearlight Shows Pty Ltd
Phone 03 9553 1688

ENTECH 2000 ULA VISION ZONES STAND #11

PROUD SPONSOR OF THE
ENTECH 2000 AWARDS

ENTECH
2000



Sound and lighting products for mobile DJs and nightclubs, from mirror balls and effects to intelligent lighting, DJ mixers, turntables and CD players



Professional moving mirrors and yokes, performance lighting control, intelligent smoke/haze, par cans and a full range of accessories



Innovative lighting and projections solutions for architectural/commercial applications - outdoor colour washing, search lights, downlighters, image projector, and LCD projection



Technics



Pioneer



NUDD

Panasonic



QUEENSLAND
26 Commercial Drive
Southport, QLD 4215
Phone: +61-7-5532-9922
Fax: +61-7-5532-4155



VICTORIA
2740 Assembly Drive
Tullamarine, VIC 3043
Phone: +61-3-9310-4999
Fax: +61-3-9310-4655

FREE PHONE AUSTRALIA WIDE 1-800-648-111 www.ula.com.au

LIGHTING

EDITED BY CATRIONA FORCER



Thinking of buying a lighting desk?

Lighting Control Options for under \$12,000

How do they stack up?

John Grimshaw invites some industry professionals to look at a range of affordable lighting desks.

In the feature starting on page 94, their comments and suggestions on each desk have been drawn together in a comparison for you to choose the right desk for your situation.

Presented as a tableau of the features any desk could or should have, this article is an essential guide for anyone thinking of buying an affordable desk in the near future.

The desks at a glance:

Jands Event 408	page 96
Strand 300/125	page 96
Compulite Photon	page 100
Colortran Innovator 24/48	page 100
LSC Axiom 24/48	page 107
Lightprocessor Q Commander	page 108
Theatrelight CueMaster 120plus	page 110

INSIDE LIGHTING



RED HOT CHILI PEPPERS
page 92

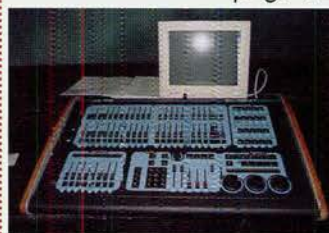

LIGHTING CONSOLES UNDER \$12,000
COMPREHENSIVE SURVEY
page 94



GRAPHICS PROJECTION GET IT RIGHT

page 104



LIGHTING CIRCULAR QUAY STATION

page 106

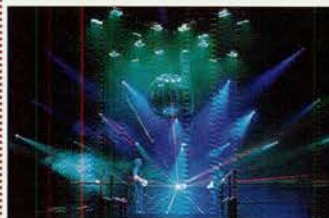

ALLAN FARKINSON PROFILE OF DANCE LD

page 111

Pavey to light Tina Turner



Australian lighting designer Jeff Pavey has hit the big time scoring a co-design of the lighting for Tina Turner's forthcoming tour. The *Twenty Four Seven World Tour* will be Tina's last stadium-sized tour and promises to be a huge spectacular.

Jeff will be co-designing the lights with the infamous Roy Bennet whilst the gigantic set is being designed by the legendary Mark Fisher. Fellow Australian Jim Straw will be lighting crew chief.

Jeff is already in the States learning how to use an Icon console whilst rehearsals start later in the month in Miami. The tour then travels through the States until mid-June and then on to Europe. Support act is Lionel Richie.

Jeff was one of Eric Robinson's right-hand-men at Jands for many years before landing the job of lighting designer for Joe Cocker and departing our shores. Joe Cocker's manager is ex-pat Roger Davies who also manages Tina Turner.

RED HOT CHILI PEPPERS

trying not to put on a production

Photos: Cat Forcer

In Sydney, lighting designer Scott Holthaus described his trip to Australia as a 'fucking technical nightmare'.

"Everyone is totally cool and kind but the gear is fucking horrible - and I never use that word!" he lamented. "I have six Cyberlights and I haven't had all six make it through a show yet. It's been one nightmare after another. At the Brisbane show I had to apologise to the band members that spent most of the night in the dark at a sold-out arena show."

Scott was using six Cyberlights, without their mirrors, as truss spots so they were particularly vital to the show.

"The stuff gets working during the middle of the day and twenty minutes before the show it goes down and never comes

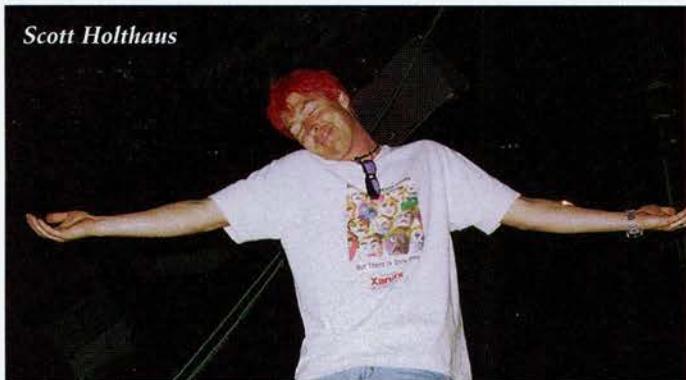
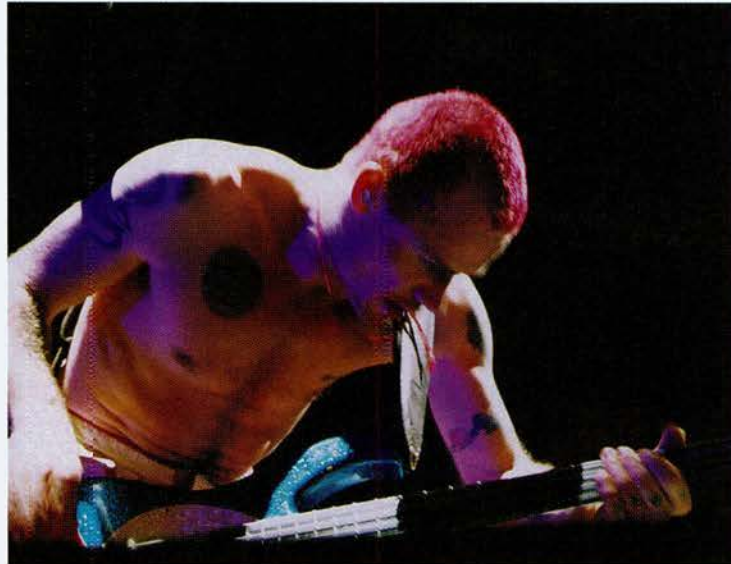

back up. I'm hoping this show is half way good but I'm afraid. When you only have 48 Par cans, a couple of Molefays, half a dozen strobes - if something goes out it's a giant hole."

Scott was quick to emphasize that he usually uses High End gear and never has a problem with it. He believed the Cyberlights in Australia were poorly maintained.

When the Red Hot Chili Peppers started touring in Europe the lighting rig was considerably larger with a 200ft more truss, 24 mirrored Cyberlights as well as Cyber-spots, 20 Studio Colors plus tonnes of strobes, floor cans and strobes.

"I soon discovered that the bigger and badder the look was, the worse it seemed to fit this band," said Scott. "Any gobo of any kind just didn't work so I went to solid colours. Hard edges didn't work either, eventually I realised that technology didn't help this band. So we ditched the Cyberlights and then the Studio Colors, then 100ft of truss full of Par cans and finally about fifty colour changers. We're now



down to one row of Pars on two trusses with no colour changers! There are a couple of strobes and Molefays on the floor with colour changers on them.

"I let the band do everything. It's so simple. The tricks you learn like using blue in between songs and using lacy gobos for the slow songs, I've tried to do the exact opposite. The colours are all wrong, very wishy-washy and at any time there's only 8K of lights on."

Gear bought out with the band included the yokes and seats for the Cyberlights which bolt onto the truss. Also shipped over were the boxes, Wybron colour changers, strobes, and side strobes with colour changers, the rest of the gear was supplied locally.

"The Wybron colour changers are unbelievable," said Scott. "I've never replaced one or had to reset one, ever. Everything else just kind of sucks."

Using Cyberlights as spots was very useful for Scott in countries such as Russia where there was always a 10 second delay in interpretation!

"This way I can say 'you're on the guy with blue hair' to the operator and then I control the rest," said Scott. "Intensity and colour I can control from the desk. With Cybers you can ride them manually with the show. The video people hate my guts! At the bands request, we never alter the show for television so it is dark, slashy and uncorrected, basically bad TV lighting. I had to change from the WholeHog because the four

Lighting::CONCERT

BY::Cat Forcer

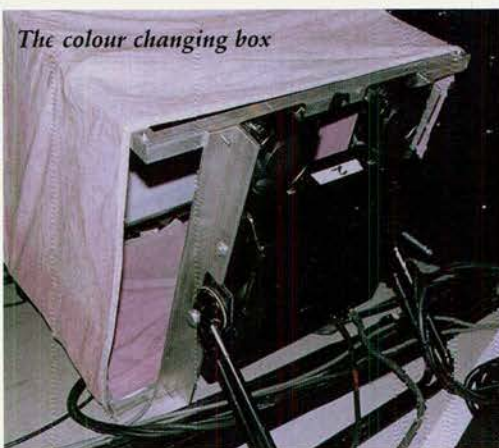

The colour changing box

followspot handles took half the desks busking channels away. I'm now using an Echelon which is fine and easy to use."

Scott is proud of the lack of front light and the asymmetrical side light which he uses 'in spots I'm not supposed to'.

The first stage element you notice

with this Red Hot Chili Peppers show are the seven boxes strung randomly from the trussing. These are the result of Scott's search for light sources which were not actually lights.

"When I took all the technology away there was a large hole, I had to have something to break up the two-dimensional aspect of the screen and the lack of anything else," explained Scott. "The boxes contain an ETC Source Four Par with a Wybron colour changer in each one. They fold real flat and travel in cases. It was a

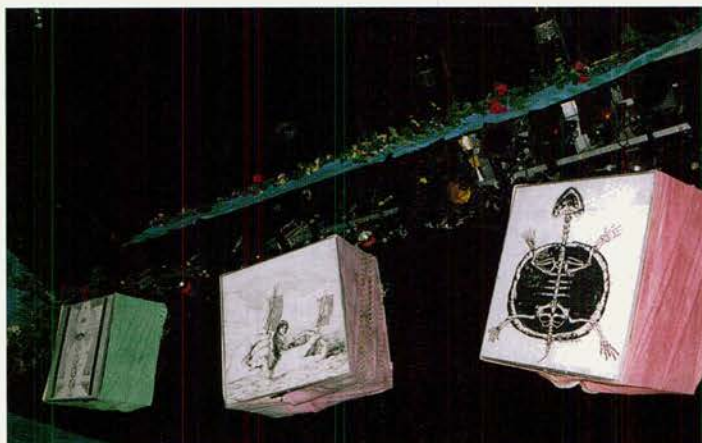

thing we thought of very last minute and it was done very quickly and easily."

The boxes are made of aluminium and the Wybron changer lives in them as well as a fan and the Par just slides on, held on by the colour changer. Stickers of non-specific images 3ft x 3ft are attached to the boxes. Fake foliage was also strung around the stage for added effect.

The video for the show is via two Electrohome Roadies which project a 24ft x 60ft image, another reason why Scott could cut down on lighting.

"The band really want to appear like they are not trying to put on a production," said Scott. "They don't want to look polished, they want to be tongue-in-cheek, just four friends playing together. The video is very candid stuff we shot out of our own personal digital video cameras. It's quickly conceived and simple."

"Minimalist is good. At the Big Day Out festival the Red Hot Chili Peppers followed Nine Inch Nails who have a beautiful show with thousands of moving heads and strobes designed by Roy Bennett and Gary Westcott. I just think it's funny that we followed that. We're a two truck tour with a skeletal crew that can set up in a couple of hours. We don't need to impress the world with a big, bad-arse show that costs an extra \$30,000 a week. We didn't cut down the show for money reasons, it was all artistic, but the savings are a benefit."

PRODUCTION PERSONNEL

Tour Manager *Louis Mathieu* Production Manager/Video *Grievovorko* Production/Tour Manager Assistant *Lyssa Bloom* FOH Engineer *Dave Levine* Monitor Engineer *George Squires* Lighting Director *Scott Holthaus* Video Tech *Johnathan Doral*

gemini™
SOUND PRODUCTS WITH SOUND IDEAS

**MIXERS
CD PLAYERS
TURNTABLES
AMPLIFIERS**

**WIRELESS MIC SYSTEMS
SPEAKERS
EQUALISERS
SAMPLERS**

DISCO WORLD PTY LTD

SHOWROOM: Factory 20, Cave Hill Road, Lilydale VIC 3140

Ph 03 9735 0588 Fax 03 9739 5441

Web: www.discoworld.com.au

Email info@discoworld.com.au



ENTECH STAND E16

Lighting Control Options for under \$12,000

Connections does the research for you

For anyone, buying a lighting desk often becomes a leap of faith. Balancing the cost of the desk against the features you think you might require (for the indefinite future) is a very hard judgement to make. To really understand any desk takes at least a few hours of use, and most people can not afford the time to do this. So nearly every desk that is sold is done so on the reputation of the manufacturer. The fact that names like Jands, Strand and others have stood out, survived and prospered over time goes a long way to ensure their market share for the future. However, making an informed decision about which desk to buy remains an elusive problem.

Looking at the problem from the point of view of the manufacturer for a moment, the company has to decide to make a desk has to choose what "type" of event the desk is going to be used for. Is it for straight theatre, a club, concert production, school hall, shopping centre, etc?

Some manufacturers try to cover as many options as possible with the one device, others are very specific, and some make modular systems so the user can buy the parts that are required. In the limited market that is the world lighting industry, competition is furious for the buyer's dollar – and this creates a large range

for the user to choose from. However, the side effect of this is that the buyer can be all too easily overwhelmed by the choices available.

We at Connections wanted to try and address this problem, so we decided to look at a limited price range of the lighting control market. Originally the intention was to compare desks under \$12,000 against one another. However, after a discussion with the industry professionals that were invited to the comparison, it was decided that the desks could not easily be compared against each other because they all were designed for specific market sectors.

Instead, we looked at each desk with a view to developing a series of questions that could then applied to any desk. These questions may not cover all of the features each desk might have, but they are a useful guide.

So in the end, all of the desks profiled here has had this group of questions asked of the desk. Each was lined up along the front of the stage at the Independent Theatre in North Sydney. Then one by one, each was put through its paces by the panel. The DMX stream output by the desks controlled the in house 48 dimmers, and two Mac 600s (kindly supplied by Show Technology). *continued over*

The Panel



Matt Binney is Company B's Technical Manager (at Belvoir Theatre)



Paul Collison is a freelance lighting designer



Roger Hind owns and operates the lighting production company "Theatricks"

Creativity and technology.

A spectacular combination.

Creative lighting for shows, theatrical productions, television studios and entertainment venues.

Giotto moving head fixtures, with their ground-breaking technical originality, are the result of twenty years' experience: completely designed and tested in the SGM Research & Development Centre with the consultation and collaboration of world-famous show industry professionals and lighting designers.



Acanto

Giotto Spot 1200

- MSR 1200SA lamp powered by an electronic ballast • 540° Pan (3.8 sec.) 270° Tilt (2.4sec.) • 16-bit control
- Automatic head repositioning • 72 colours • 4 beam angles (9° - 12° - 15° - 18°) • Electronic focus • Iris • 4 rotating
- 4 fixed gobos • 2 rotating prisms • Variable frost.

Cover for using Giotto Wash 1200 and Giotto Spot 1200 outdoors. The dome, in highly heat resistant perfectly transparent polycarbonate, has an ABS body and built-in ventilation system.

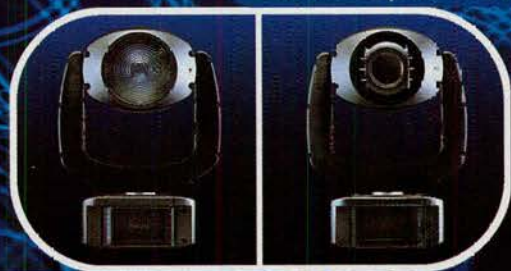

Giotto Wash 1200

- MSF 1200 lamp powered by an electronic ballast • CMY colour mixing • 200mm Fresnel lens with zoom facility (18° - 35°) • 540° Pan (3.8 sec.) 270° Tilt (2.4sec.) • 16-bit control • Automatic head repositioning • Luminosity of over 30,000 lux at 5m./18° angle.

Giotto Barndoors



Exclusive motorized barndoor system for theatre and television applications. Each of the 4 barndoor leaves has an independent motor and a fifth motor rotates the entire group through ± 95°.

Light Dome

VISIT US AT SIB 2000 • RIMINI, 26th-29th MARCH • HALL G • BOOTH 59-97 / 56-94



SGM Elettronica srl • Via Pio La Torre, 1 • 61010 Tavullia (PS), Italy
 Tel. +39 0721 476477 • Fax +39 0721 476170 • <http://www.sgm.it> • E-mail: info@sgm.it
 Jansen Limited • 4 Huntly Ave, Grafton • Auckland • New Zealand
 Tel. +64 9 3773663 • Fax +64 9 3075884 • e-mail: mail@jansen.co.nz

Lighting::PRODUCT COMPARISON

BY::John Grimshaw

manufacturer: **JANDS**

desk: EVENT 408

price (ex tax): AU\$9831.96

distributor: JANDS ELECTRONICS +61 2 9582 0909

No. of DMX Channels: 512 ON TWO SEPARATE OUTPUTS

General Information

Designed for use in small shows that include conventional lights, colour scrollers and/or a limited number of moving lights.

Do you want manual fader control of individual channels?

The 408 has 48 faders on two presets that can be used in normal mode (2 sets of faders for channels 1-24) or "wide" mode (use all faders for channels 1-48).

Do you want submasters?

There are 99 pages of 8 Assign Masters that are used for most of the functions on this desk. The functions include simple memory recall, chases and "stacks" of crossfade cues. Memory limitations prevent every position being used as chases and/or stacks, but how often are you going to want more than 792 masters?

Do you want intelligent lighting control?

An excellent interface allows for quick and precise control of moving lights. A "Palettes" section allows for recording parameters (position, colour & beam) for groups of fixtures.

Do you want to run a sequence of preset cues in a generic "theatrical" situation?

Control in this way is achieved by using the "stack" method. A consecutive series of cues are recorded into an assign master, all with individual times for each cue. The "Flash" button below the fader becomes the "Go" button.

Do you want to run chases and other effects?

This desk is designed to run this type of operation. A step and dwell time can be set for each chase. The chase numbering (0-999) suggests that there are more than enough recording possibilities for most situations.

Do you want inexperienced operators to be able to immediately control the desk?

For those people that have never sat at a desk like this before, this desk will take time to learn. Quick control of individual channels is possible, but control of the complex functions is not immediately obvious.

Do you want to be able archive or move the show information from desk to desk?

This desk uses a standard floppy drive to save the show. As these disks use the PC format, the archived information can be stored in any compatible computer.

Do you want to be able to "offline edit" your show?

Not possible

Do you want a video display?

The current generation of the Event 4 now includes a video output for the desk. This can display features of the desk, as is required to set some of the parameters.

Where is it repaired if a fault develops?

Service dealers around the country

Any other interesting features noted by the panel?

This console is a nice revision to the Event series - especially the inclusion of the "Flying Pig" intelligent light software and the VDU.

Any drawbacks noted by the panel?

The control layout makes the desk a little hard to operate for operators not experienced on the desk. Also the new control design (from previous versions) means that those familiar with the previous version will require some re-learning of the desk. With only 8 assign masters on this desk (and even 16 on the 416), this desk's functionality is less than the standards often seen on other desks. This is only a drawback in situations where submasters are used a great deal.

Other desks by this manufacturer

This is the smaller model in the Event 4 series, the larger one being the 416 @ \$14750 ex-tax. Jands also make the Hog series of control desks.

manufacturer: **STRAND**

desk: 300 SERIES / 125

price (ex tax): YET TO BE DETERMINED BUT UNDER AU\$ 12,000

distributor: BYTECRAFT PTY LTD +61 3 9587 2555

No. of DMX Channels: 125 DESK CHANNELS / TWO SEPARATE OUTPUTS



General Information

Theatrical lighting desk with modular design so that panels and/or LCD screens can be added as required. The model tested was a pre-release demo model, and some features may vary slightly to the production model, due for release, and available from March.

Do you want manual fader control of individual channels?

Manual fader modules are available as an option for up to 96 faders. The 125 will model we saw was not fitted with this feature. Modules for instant channel control are going to be available in 24/48 and 48/96 formats, and can be retrofitted to desks after purchase.

continued over



Living Light

Delicate or overpowering, static or dynamic, light is a living element full of possibilities for lighting design.

JOIN THE REVOLUTION

TO BE LAUNCHED AT ENTECH STAND I8

The most affordable MAC moving head ever!

The Fastest MAC moving head!

ULTRA COMPACT Fits into rooms of all sizes!

Powerful 150 watt beam source!

Attractive complementary design!

To see the MiniMAC in ACTION, visit our website at www.martin.dk

Martin
Professional Lighting
AUSTRALIA

A division of Show Technology Australia Pty Ltd

13-15 Bridge Street • PO Box 480 • RYDALMERE NSW 2116 • Phone 61 2 9898 1111 • Fax 61 2 9898 1222
E-mail: Martin@showtech.com.au • Website: <http://www.showtech.com.au>

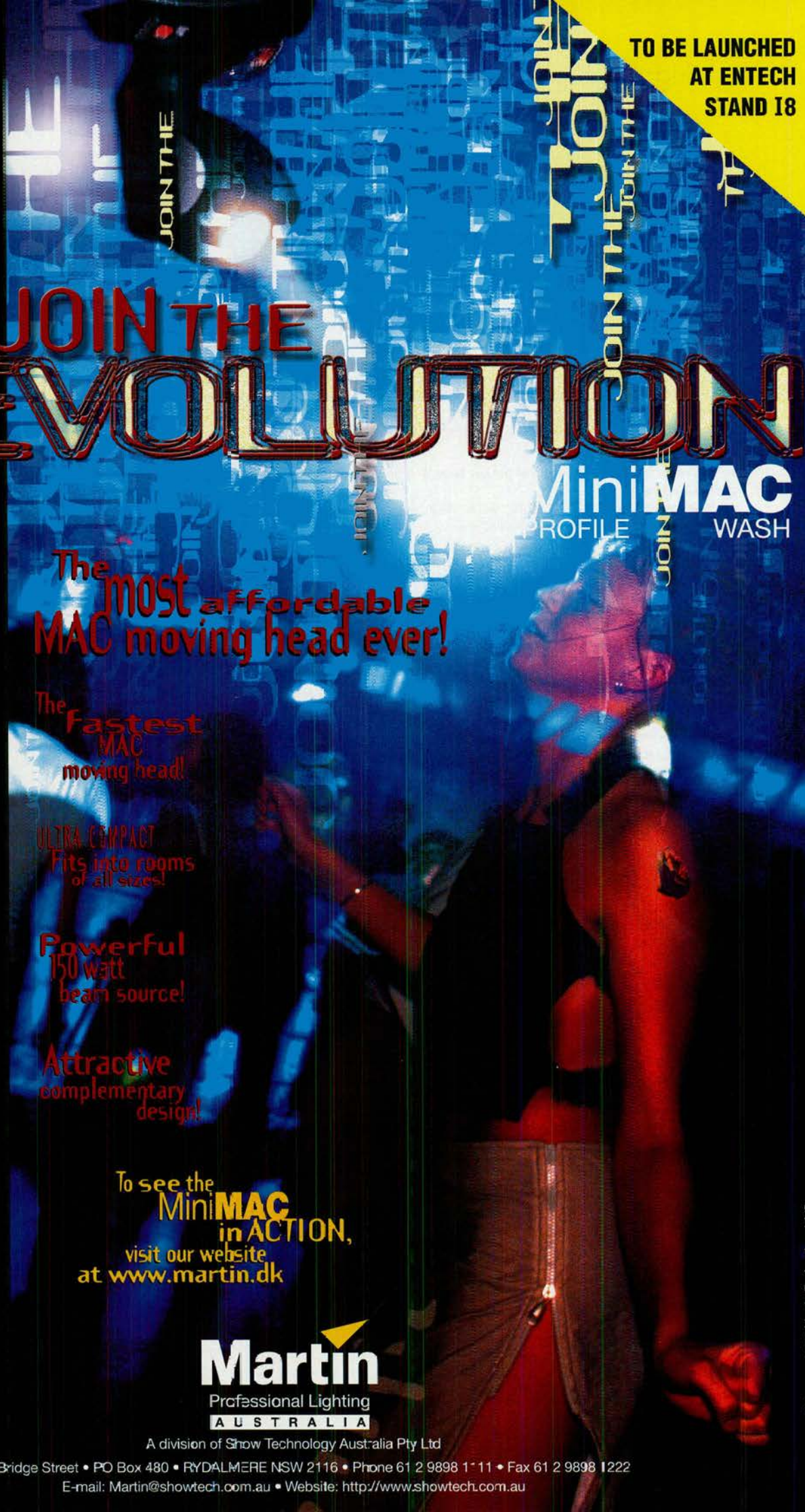

JOIN THE JOIN THE JOIN THE JOIN THE

MiniMAC PROFILE WASH

© 2000 Martin Professional A/C

STRAND

continued from previous page

Do you want submasters?

There are 4 pages of 24 submasters. These are standard submasters that a "state" can be recorded to.

Do you want intelligent lighting control?

The intelligent lighting control software is the same as for the 500 series desks. Libraries of standard fixtures are in built, and can be upgraded. One good aspect to the way this feature is designed is that you do not lose numerous desk channels for each intelligent fixture you use. Of the 125 channels, when a fixture is allocated the actual DMX control channels can be anywhere in the 512 possible channels of output, and only the intensity control is allocated to the limited number of available desk channels.

Do you want to run a sequence of preset cues in a generic "theatrical" situation?

This desk is specifically designed for this function, and most aspects of running a show this way are controllable.

Do you want to run chases and other effects?

Up to 300, 99 step chases can be recorded, and assigned to cues and/or FX busses.

Do you want inexperienced operators to be able to immediately control the desk?

This desk will take some hours for a novice to learn, but operators familiar with other Strand products should pick it up much faster. The fact that it uses the same software as the 500 series certainly helps. Also there are options for making the desk and/or display behave in the same way as other desks.

Do you want to be able archive or move the show information from desk to desk?

Not only can the desk memory be saved to a floppy, archived on a PC, and loaded into other Strand desks, but an operator can save all of his/her set up preferences and move these between desks without interrupting the show memory.

Do you want to be able to "offline edit" your show?

A precise answer to this question was not available at press time. Presumably editing is/will be possible using Strand software, but expect to pay for the privilege.

Do you want a video display?

The desk comes standard with one video display output. a second display showing channels only is optional.

Where is it repaired if a fault develops?

Bytecraft service all Strand equipment in Australia. Simple faults may be able to be dealt with by the nearest supplier. The Melbourne office deals with major problems.

Any other interesting features noted by the panel?

There are MANY features included on this desk. One that will save hours of plotting time when using intelligent lights is the "move while dark" feature. Imagine being able to plot the show without having to go back and plot the moves between the cues. There is also a "preheat" function that will preheat channels before use in a cue. Powerful macro control features, including full day/time activation for any macro. Bytecraft says that all software will be enabled with the shipped desk, so no paying for enhancement upgrades as for the old GSX.

Any drawbacks noted by the panel?

The "plastic fantastic" (GSX) is to be replaced by the "plastic fantastic 2". The faders and buttons, in fact the whole interface feels a little fragile. A power interrupt failure causes a long wait before the desk reboots - you should seriously consider getting an uninterruptable power supply as designed for use with computers.

Other desks by this manufacturer

The old GSX range will probably be phased out by this new range, so you may be able to pick up a bargain if you twist someone's arm. Otherwise, this 300 series will come in eight different forms - 24/48, 48/96, 125 (profiled above), 250, 400, 600, 120 submaster

continued over

NEWS

PATENT AND FINANCE FOR COLOR KINETICS

Color Kinetics of Boston has announced the awarding of a US Patent, the first issued patent in its field, for its exclusive Chromacore technology. The patent, No 6,016,038, covers stand-alone and network control of multiple LEDs for illumination and display.

The company state that Chromacore is an integral part of their growing intellectual property portfolio which includes US and international filings encompassing a number of emerging digital technologies. "Our patent is a major milestone for Color Kinetics, capping over two years of industry recognition for Chromacore and the virtually unlimited applications it enables," said president and CEO George Mueller.

In a parallel statement, Color Kinetics also announced the completion of its third round of equity financing, with Deutsche Bank as the lead investor. The round featured significant participation from the company's existing investors as well as from several new investors, and has raised over \$13 million for the company.

MARTIN BEAT VARI-LITE US INJUNCTION

In February and March of this year Martin Group will introduce two new products on the important American market. The MAC 500SP and MAC 600NT will replace two of the products that continue to be affected by the injunction which prevents their sale in the USA.

The products are primarily used in the professional segment, including concerts and tours, as well as in film and TV studios. Martin's own engineers have developed a completely new patented colour mixing system for the MAC 600NT. Both products lie outside of the American patent, which is the basis of the litigation.

The Federal Appeals Court in Washington DC is expected to hear the appeal sometime in February. Regardless of the decision in the case, Martin can sell the new products in the American market and have essentially won back their freedom of trade.

Hereafter only one less significant product will continue to be excluded from the American market. The economic effect therefore of an eventual continuation of the injunction will be substantially reduced.

Martin CEO Kristian Kolding stated, "The speed with which we have developed the color mixing system for the MAC 600NT is an example of the Martin R&D team's exceptional capabilities in product development. We are proud to offer these two new products to the American market and are confident they will meet with success."



LSC CRUISING IN 2000

Carnival Cruise has just purchased innovative lighting control systems from LSC Lighting Systems for their 132,353 ton ships Carnival Triumph and Carnival Victory. Servicing their hot spots of onboard entertainment with full DNA DMX512 systems, these two installations were done by H.M.S. in Italy

- Other recent and successful installations of LSC lighting control equipment include the New Years Eve Concert in the Domain, Sydney 2000. Powered by four LSC 48 channel Touring Dimming Systems, equipment was supplied by Chameleon Touring Systems, Sydney, Australia.
- LSC Distributor, Feiner Lichttechnik, Germany was successful in installing Axiom 24's, Multisplits and DMX splitters in retail stores in Munich and Hamburg for a hi-fi video computer chain, Saturn-Hansa. This follows the installation of Multisplits to NOB, Germany's largest TV station.

- Newly appointed distributor, Dragon Music in Fiji installed a number of Atom desks and ePAK dimmers at the ever-sophisticated Sheraton Resort in Fiji.

- Last but not least, Lightwaves, Melbourne have been very busy installing a number of large DMX512 networks and turn key equipment for theatres and nightclub circuits. Projects and equipment included the new Colonial Stadium with DNA networks and Wallpaks; Mt Scopus College with DNA networks, Axiom 60, Wallpaks and ePAKs; Moonee Ponds Cultural Centre with DNA networks; and St Bernards College with DNA networks, Wallpaks, and Axiom 36.

Welcome to the **Family**

Since its introduction in 1996 the Chroma-Q has revolutionised the world of colour changers, opening the doors of technology to a wide range of users.

Continuing this tradition, the Chroma-Q M-Range introduces a family of new units that open the doors of affordable and reliable colour changing to a much wider range of fixtures:

M1 - for fixtures from 575 W up to 1 kW

M2 - for fixtures up to 2 kW

M5 - for fixtures up to 5 kW

M8 - for 8-Lite fixtures



**SETTING NEW STANDARDS IN
PROFESSIONAL COLOUR CHANGING**

Dealer Enquiries Welcome

A.C. Lighting Ltd.,

Unit 3, Spearmast Industrial Park, Lane End Road,
Sands, High Wycombe, Buckinghamshire, HP12 4 JG. U.K.

Tel: +44 (0)1494 446000 Fax: +44 (0)1494 461024

E-mail: sales@aclighting.co.uk Internet: <http://www.aclighting.co.uk>

Write in Reader Service Number: 157



Lighting::PRODUCT COMPARISON

BY::John Grimshaw

manufacturer: **COMPULITE**

desk: PHOTON

price (ex tax): AU\$9,999

distributor: COEMAR DE SISTI AUSTRALIA +61 3 9467 8666

No. of DMX Channels: 240 DESK CHANNELS SOFTPATCHABLE TO ANY DMX



General Information

This is a theatrical show desk, primarily designed to run cues in sequence.

Do you want manual fader control of individual channels?

Not available with the desk tested.

Do you want submasters?

There are 20 "controllers" that can be used for a group of channels, a memory, a chase or as a submaster.

Do you want intelligent lighting control?

It is possible to control intelligent lights, and there are certainly enough channels for this, but using these fixtures will take time due to the fact that the interface is not really designed for this kind of work.

Do you want to run a sequence of preset cues in a generic "theatrical" situation?

This is what the desk is built for, and it does this simply and well.

Do you want to run chases and other effects?

99 effects can be recorded, each with a fixed step fade time of 0sec, and a variable dwell time for each step. Unfortunately, this function requires that all channels that are active in any particular step be at the same level.

Do you want inexperienced operators to be able to immediately control the desk?

By far the most striking feature of this desk was the fact that we were able to get into its functions, and program the desk within five minutes of the first time any of us had seen it. The controls are functional and obvious to follow for any operator that has had previous experience or other desks. New operators can expect to have to spend a little time to learn the interface, but this should be a relatively quick process.

Do you want to be able archive or move the show information from desk to desk?

This desk uses a standard floppy drive to save the show. As these disks use the PC format, the archived information can be stored in any compatible computer.

Do you want to be able to "offline edit" your show?

There is a free DOS based editor, or the associated Compucad Software (which is a full 3D cad lighting design program @ \$900) can

also edit the show.

Do you want a video display?

The desk has a standard video output that gives all of the displays you would expect. The desk can be run without the display, but it is not ideal.

Where is it repaired if a fault develops?

Service agents in Perth, Melbourne, Sydney and Brisbane

Any other interesting features noted by the panel?

DMX input is separately soft patchable to the control channels. There is a "Free Dimmers" function that will instantly display which dimmers are not used or assigned. Of the desks tested, this desk was the best able to cope with a power interrupt, with a fast reboot straight back to the lighting state and cue that the desk was doing prior to the power failure.

Any drawbacks noted by the panel?

Maybe the price is a little high when compared, for example, to the Colortran desk. Some might consider this drawback is offset by the ease of use and/or the offline editing options.

Other desks by this manufacturer

This is the base model in a good range of desks, the next one being the "Spark" which adds a 2nd DMX out and moving light control for \$13,990 ex tax.

manufacturer: **COLORTRAN**

desk: INNOVATOR 24/48

price (ex tax): AU\$9325 (INCLUDES GROOVY BLACK MONITOR)

distributor: MEDIAVISION PTY LTD +61 2 9816 4055

No. of DMX Channels: UP TO 386 CONVENTIONAL CHANNELS AND 1536 CHANNELS AVAILABLE FOR INTELLIGENT LIGHTING CONTROL - 3 DMX STREAMS

General Information

This is a theatrical based desk that is designed to control lighting in a wide range of situations.

Do you want manual fader control of individual channels?

The Innovator has 48 faders on two presets that can be used in normal mode (2 sets of faders for channels 1-24) or "wide" mode (use all faders for channels 1-48).

Do you want submasters?

There are 24 submasters, and as many pages of them as you want (We stopped trying to find a limit at 1000 pages). They are simple submasters that "snap shot" records the DMX output of the desk (on all 3 DMX streams)

Do you want intelligent lighting control?

The Innovator has very good intelligent lighting control abilities once you understand how to operate the desk. There is a comprehensive library of fixtures, and new additions are easy downloaded and installed from the Colortran web site. Alternatively, the user can create his/her own fixture profile if necessary.

Do you want to run a sequence of preset cues in a generic "theatrical" situation?

This desk is designed for this type of operation. One nifty function of this part of the desk is that it has two cue busses. That means that you can be playing cues from either or both busses simultaneously.

Do you want to run chases and other effects?

There are up to 99 chase effects that can be recorded

Do you want inexperienced operators to be able to immediately control the desk?

Programming the desk requires a little bit of time to learn and understand the interface. Colortran have designed the interface to be reasonably straightforward, but there are just enough differences so that you need to spend time learning the desk before you use it.

continued over

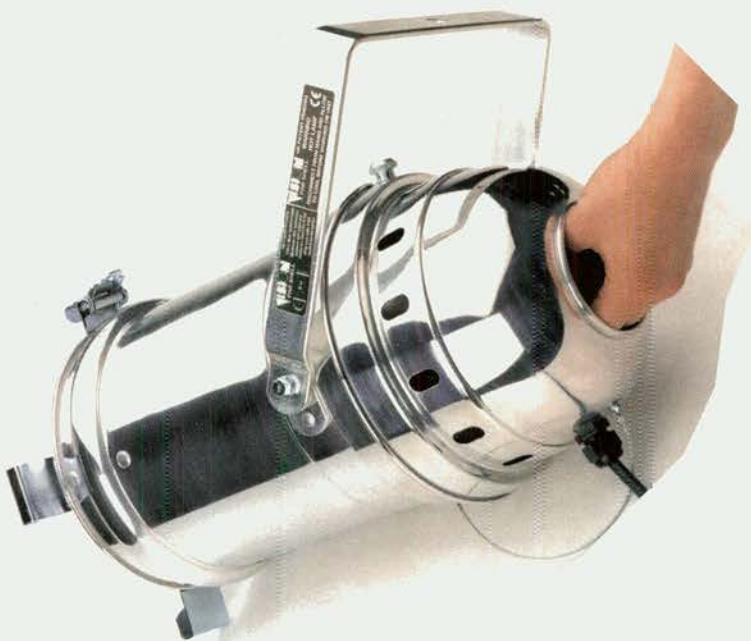

Don't get a shock, get a Parshell

VISION™
PARSHELL

The Vision Parshell allows safe adjustment of Par lanterns without causing the overheating problems often associated with lamp adjusters. Fitted in minutes the Vision Parshell ensures the lantern is fully earthed and all electrical components are double insulated to the touch, making it the safest way to upgrade your Par lanterns.

- *Universal - fits most Par 64 and 56 Lanterns**
- *Fully Earthed*
- *Double Insulated*
- *115/230V at 1kW rating*
- *Does Not Cause Overheating Problems*
- *Simple Installation - No Special Tools Required*



Don't say we didn't warn you!

Dealer Enquiries Welcome

A.C. Lighting Ltd, Unit 3, Spearmast Industrial Park, Lane End Road,
Sands, High Wycombe, Bucks HP12 4JG, England
Tel +44 (0)1494 446000 Fax +44 (0)1494 461024

* Not suitable for use above
250°C. Consult dealer for list
of compatible lanterns

E-mail: sales@aclighting.co.uk
Internet: <http://www.aclighting.co.uk>



Write in Reader Service Number: 158

COLORTRAN

continued from previous page

Do you want to be able archive or move the show information from desk to desk?

This desk uses a standard floppy drive to save the show. As these disks use the PC format, the archived information can be stored in any compatible computer.

Do you want to be able to "offline edit" your show?

Available at the end of 2000

Do you want a video display?

The desk comes with a video monitor, and there are plans to have a second VGA output available in the future. Having a black monitor is an obvious plus that is often overlooked by other suppliers. The testing panel noted that the colour scheme is a bit garish!

Where is it repaired if a fault develops?

Sydney or Melbourne

Any other interesting features noted by the panel?

Knobs for dollars, this desk has the best price/features ratio of the desks looked at in this comparison. The controls are nicely spread out, and the desk has a good ergonomical feel to it.

Any drawbacks noted by the panel?

It is physically a bit big and heavy. LCD screen is a bit small, and sometimes hard to read.

Other desks by this manufacturer

This is the base model in a range of desks. The other models are the 48/96 @ \$11,961; 72/144 @ \$17,660 (that is HEAPS of faders!); and the Innovator 600 (no channel faders, better features) @ \$14,529. Hand held remote to be available in 2000.

continued over



new products::

LOLER LADDER

White Light has announced a new, safe and fully rated solution to a standard lighting problem within the live performance industry. Until now, adjustable lighting ladders have generally been adjustable frameworks constructed from scaffolding. However, the advent of the new Lifting Of Loads and Equipment Regulations, which came into force during 1998, means that this solution is no longer acceptable.

White Light designed a new adjustable ladder system, christened the Loler Ladder. They consist of 2m vertical tube sections with spigots to accept cross-pieces at spacings suitable for commonly used conventional and moving lights. Cross pieces are fitted onto and then bolted to these spigots to form ladders with the desired rung spacing and, since standard diameter pipe is used throughout, lanterns can then be hung on the ladder using their standard hook clamps. The uprights are fitted with rated hanging points, allowing the ladder to be flown safely. They are built for White Light by leading trussing specialists Tomcat.

NEWS

SHOWCRAFT CHANGERS IN MELBOURNE

The tower and structure on Melbourne's premier high-rise, 101 Collins St, are now permanently lit with Showcraft Architectural colour changers. Four ACC2000 changers containing five computer controlled colour filters and a blackout on a 2kW HQI Sports light provide the colour for the spire sections of the tower. Together with these four Showcraft ACC250 colour changers coupled to 250W FL10 fittings providing colour on the insides of the spire structures. Showcraft's changers are also on the Victorian Arts Centre and Sydney's Centrepont Tower.

MARTIN AWARDED CONTRACT FOR THE LARGEST AUTOMATED EXTERIOR COLOUR CHANGING LIGHTING SYSTEM IN THE WORLD

Martin Professional's US subsidiary, Martin Professional Inc., has been awarded the lighting contract for the Sepulveda/Century entrance of the new LAX Gateway project.

Designed and specified by Los Angeles based Dawn Hollingsworth of MRH Design (Moody, Ravitz, Hollingsworth Design Inc.) the project will feature nearly 500 Martin Professional Exterior 600 lighting fixtures.

The popular outdoor colour changers were ultimately chosen by MRH to illuminate the entrance's 15 Sepulveda Circle Columns. Each column is approximately 30 - 60 meters tall and 4 meters in diameter and is made of a frosted glass material.

The illuminated columns will stand at the entrance/exit to the Los Angeles International Airport and will be seen at night by the over 100,000 people who pass through LAX each evening.

The Exterior 600 fixtures will be programmed to change colours and will synchronize with an additional 15 smaller glass columns located on Century Blvd, the main road approaching LAX. The complete lighting project will be controlled via a customized system of Martin ProScenium lighting controllers.

Helix Electric, Inc., constructors and engineers for the \$25 million LAX Gateway portion of the \$110 million LAX improvement project, are supplying the complete job.

Upon completion in June of 2000 the project is certain to be the largest automated exterior colour changing lighting system in the world. Completion is slated for just prior to the start of the Democratic National Convention which will be held in Los Angeles this summer. Visiting delegates will be treated to a vibrant and colorful red, white and blue welcome to Los Angeles. Over 60 Million people pass through LAX each year.

SELECON SUCCESS IN SYDNEY

Selecon's exclusive distributor in NSW, Herkes Pro Lighting rounded out the end of the millenium with a Pacific boom having sold over 140 fittings to rental companies in Sydney.

- Chameleon purchased 40 Pacifics to meet a specification for the Sydney Festival production of Elektra (the German LD wanted an entire Selecon rig) in addition to Trudy Dalgeish specifying Pacific for the Domain concert series. Pacifics also greeted 2000 in style thanks to Spectak using them as Pani replacements on the New Years Eve concert in the Domain.

- Roger Hind now has Pacifics for his own use as well as for general hire use separate from Megatone and the Great Outdoor Lighting Company. Lots of Watts and 3200 Lighting have each purchased a number of Pacifics bringing the overall stock available for hire in Sydney to a significant level.

ETC EUROPEAN APPOINTMENT

ETC has announced the appointment of Mike Lowe, previously of Teatro Srl, as its new managing director for ETC Europe. Lowe former lighting equipment manufacturer Teatro Srl, Italy, 13 years ago and prior to this was with Rank Strand, where he was managing director of the company.

Download free WYSIPAPER & demo at:
www.wysicad.com

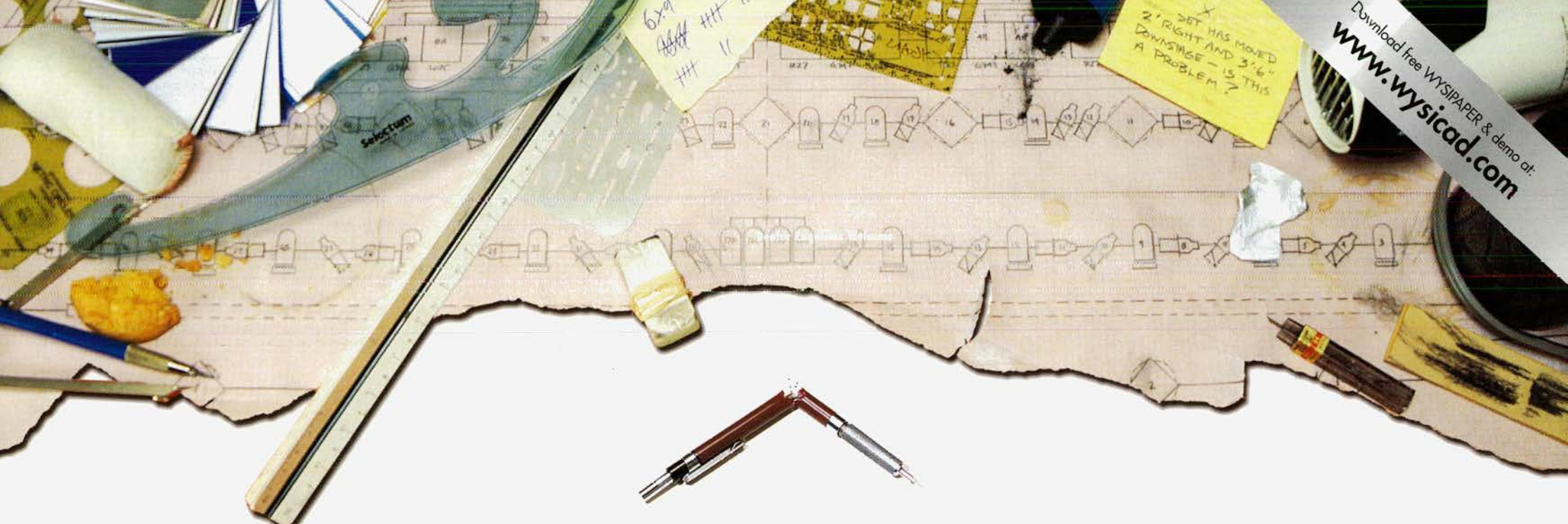

What has your lighting plot done for you lately?



Customizable Schedules & Counts

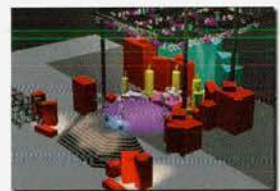

Real Time Softedge Simulation



Interactive Plot Data Editing

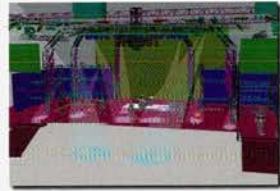

Gobos, Prisms, AutoFocus Console Control

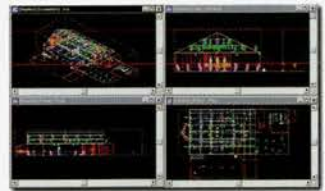

Seamless 2D & 3D CAD

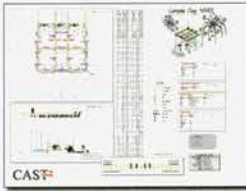

Comprehensive Plots With Presentation Space



Photo Quality Rendering



Drag And Drop Patching



Developed By: **CAST** lighting

Worldwide Distribution: 

A.C. Lighting Ltd. UK
 Unit 3, Spearhead Industrial Park, Lane End Road,
 Sands, High Wycombe, Bucks HP12 4JG England.
 Tel +44 (0)1494 446000 Fax +44(0)1494 461024
 Email: sales@aclighting.co.uk
 Web: <http://www.aclighting.co.uk>

Dealer Inquiries Welcome

Pick the WYSIWYG package right for you: WYSIPAPER, WYSICAD, WYSIWYG500, or WYSIWYG2000

wysiwyg ver 3

GRAPHICS PROJECTION IN A DIGITAL AGE

We're getting more computer literate and our email has become an essential tool. With less time on our hands than ever we still find that we have to master new skills to remain efficient. It's impossible to keep up, and filter out, just the technology that has relevance for us, so we get by with the information that we snap up around us. Sometimes right, sometimes wrong, often incomplete and frustrating. We need the right information at the right time to ensure we get the best results quickly and painlessly.

Concepts such as image resolution and even worse, file type, are a constant often misunderstood, headache. Here we will touch on the first of these issues.

SCENARIO the client hands you a CD of a scan he has proudly made of his business card, black text on a brown background. You had stated to him you needed a high resolution image so he set his new scanner to 9600dpi interpolated and set his super fast G3 to work...The client who's really on the ball, decides that his brown background was possibly not a good idea on his red brick wall and asks could you please just project the black text. (Black trees are good too.)

PHOTOGRAPHS AND SLIDES are produced by using films that can achieve varying shades of continuous tone images. Film colour and slide images will be continuous and the blends will be smooth across the colour spectrum. The resolution will be reliant upon the grain of the film which is usually extremely fine hence we can get great quality enlargements from a single slide negative. The slide in effect stores immense amounts of information which if we wanted to digitise and store, at a similar quality, would take huge amounts of memory.

PRINTED IMAGES like the images in this magazine, will be printed with what is called a halftone screen. We don't print grey ink, we print black dots close together to let your eye get an average of white and black and thus we see grey. The same goes for the other colours. We normally only print using Cyan Magenta and Yellow like the inks in an inkjet, but placing the dots of colour close or on top of each other will let you see other colours. (CMYK)

LIGHTING when we project colour, adding Red + Green + Blue will give us white and obviously turning the lights off will give us black. This is called additive colour mixing and is used by all your big screen projectors TVs and such. If on the other hand you decided to place a Cyan Yellow and a Magenta gel in front of a single light source, you would have no light output. This is subtractive (CMY) colour mixing and is for instance used in a range of moving lights to achieve different colour tones.

GLASS GOGO projections use high resolution chemical etching of a metal surface that has been deposited on a sheet of glass. Once again we either have transmission or we don't, we never have semi transparent dots. Any shadings or greyscale is achieved by placing dots of varying size close to each other. The process is the same as used in the printing industry and for full colour images the technique is once again the same. We use subtractive colour mixing (CMY) for the different shades of colour and a black (K) layer to ensure that black really transmits no light.

Another technique that is used for solid block colour is comparable to the printers spot colours. You would select specific colours to use, just like the solid colour wheel in a scan that achieves colours that are outside the CMYK gamut. Here we will only discuss halftone rasterised images.

RESOLUTION divide your page into a large number of equal size squares or cells. This would be called your screen ruling also known as linescreen (lpi) and is a grid of halftone cells also known as a raster. When you look at a B&W photo in a newspaper and see the dots of ink that make up the photo, each dot that you see is a halftone cell. The finer the dots that you see the higher the linescreen. A newspaper might be around 80lpi where a magazine might be closer to 130. A higher resolution image needs a higher linescreen to not look grainy or coarse.

DPI a misunderstood term. Dpi is the printers finest dot that would be used to fill the halftone cell with ink, the more ink in the cell the darker the image. The larger the printer dot the less dots per inch (dpi).

If you could only fit four printer dots inside your halftone cell, you would only be able to achieve four shades plus white. Doubling our dpi we would have a grid of 4x4 dots within our cell letting us achieve 16 shades plus white. Higher dpi will thus increase our number of achievable tones but it will not change the size of the halftone cell itself which is the actual 'dot' that we see. A dpi that is only four times higher than your linescreen would give you 16 shades of grey or 65536 shades of colour in a CMYK image. There is a limit to how many shades our eyes will perceive and our projection problems are more often than not based on intensity and ambient light problems than on the qty of shades. Higher contrast is often welcomed and is a product of fewer shades whereas a softer image is achieved by increasing the number of shades. The dpi gives an indication to the quality of an image but to make specifications meaningful you need to know the dpi and linescreen (lpi) of the final image and realise to what extent you will enlarge.

Joakim Odlander owns Lighting By Design, manufacturers of gobos



BROWN'S

PRECISION WELDING PTY LTD

ALLOY TRI TRUSS • BOX TRUSS • CIRCULAR TRUSS

18 YEARS EXPERIENCE • AUSTRALIAN MADE

ENGINEER APPROVED

Quality assured competitive prices

56 Mologa Road, West Heidelberg VIC 3081

Ph (03) 94552899 Fax (03) 94575044

Mobile 0412 401 469

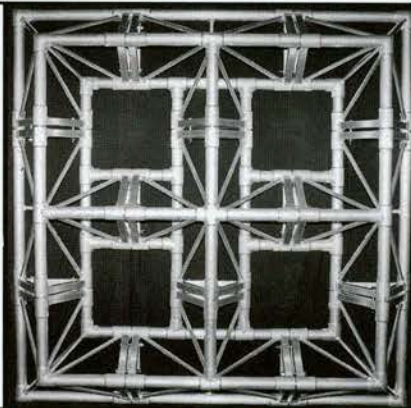

Postcards from ENTECH



MILLER

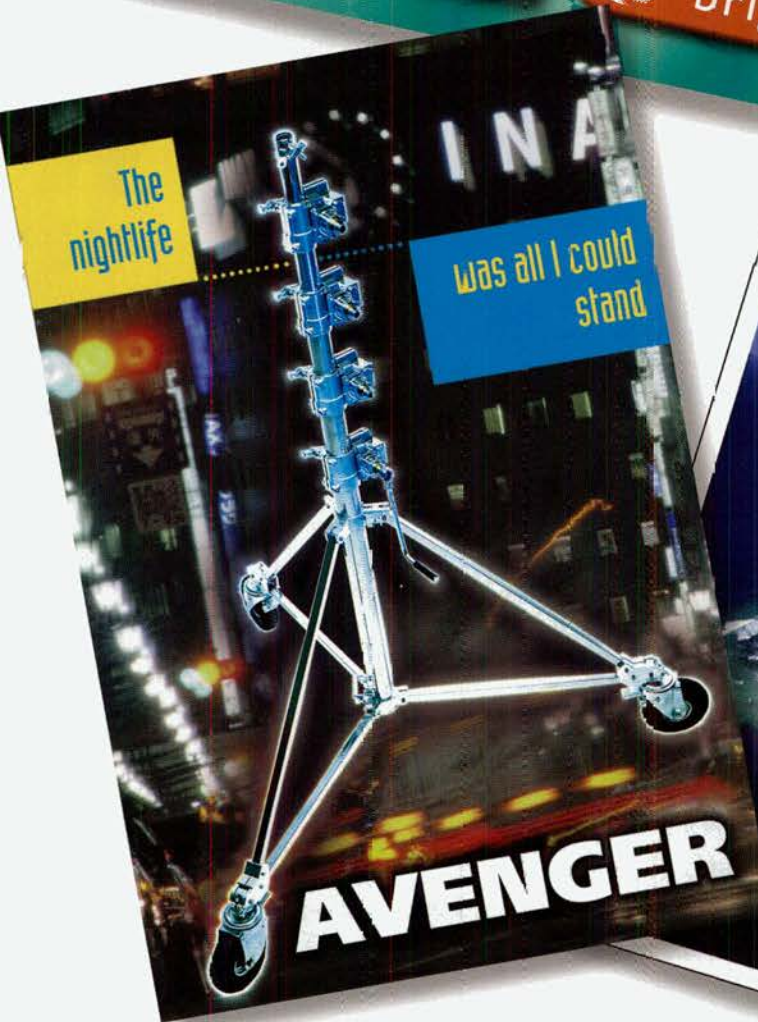
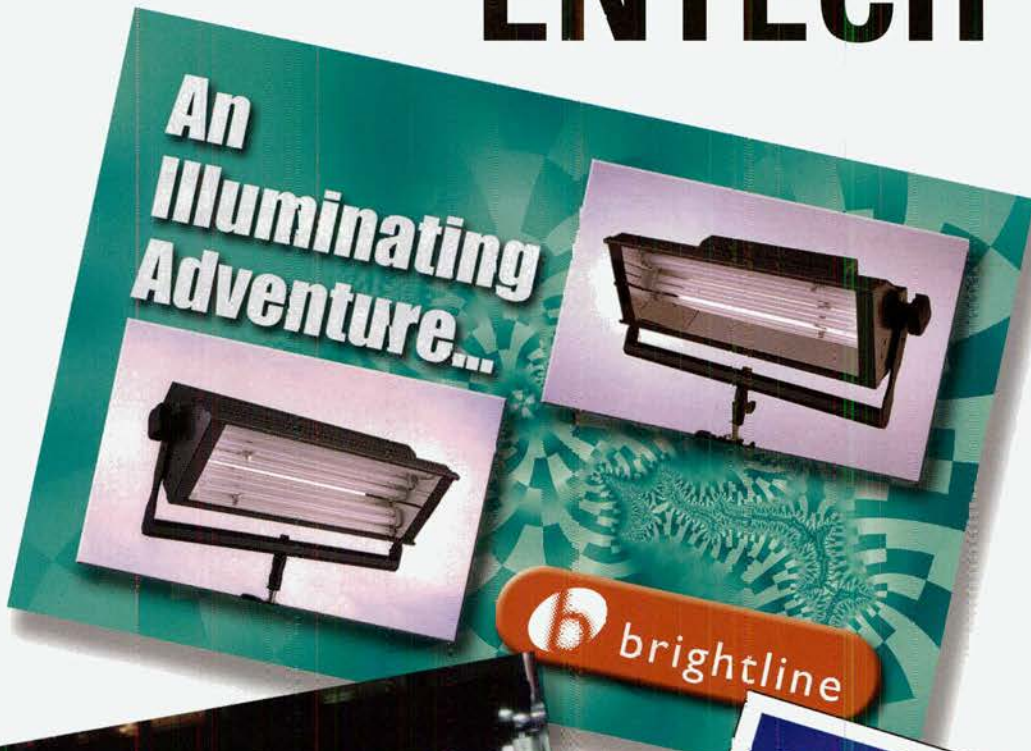

Lighting

Support

Need some new:



Par Cans...

Mirror Balls...



**Smoke
Machines...**

DYNAMITE

www.discoworld.com.au

email: info@discoworld.com.au



Disco World Pty. Ltd.™

**SEE US ON
ENTECH STAND E16**

SHOWROOM
FACTORY 20
Cave Hill Road
Lilydale Victoria 3140
Ph 03 9735 0588
Fax 03 9739 5441

Lighting::ARCHITAINMENT

BY::Cat Forcer

VIP'S LIGHT UP CIRCULAR QUAY RAILWAY STATION

As Sydney gears up for the biggest sporting event in history - the 2000 Olympics - a new idea in marketing and promotions has been created for the sporting industry.

A sporting hall of fame has been emulated at Sydney's Circular Quay Railway Station to pay homage to athletic excellence and to one of the world's biggest sporting giants - Asics.

A brainchild of KWL Advertising and Australian Posters, the concept gives Asics advertising ownership of Circular Quay Railway Station ... a process that took months of careful planning and design to ensure that the transformation occurred without a hitch.

As John Smallwood, CEO of Australian Posters said, "The key to station ownership is it allows advertisers to create an environment that reinforces the brand experience and Asics have done a fantastic job in achieving just that".

In fact everyone entering the station at Quayside and at platform level is met with a celebration of sport - huge banners displaying some of the world's finest sports people, past and present, are suspended from the ceilings; action shots liven the walls; and the Station floor has the feel of a running track. There's even two giant Asics shoes to capture the attention of all.

But to add that touch of class and to heighten the senses of the 30,000 commuters that pass each day, a variety of images spin and rotate along the walls of the station using the latest lighting technology from manufacturer Clay Paky.

Chosen for their bright optics and versatility, four Clay Paky VIP DIA Image Projectors - together with four Rotogobos - have been used to give the display an element of visual impact using movement.

The VIP DIA's project a plethora of images onto white sails that have been hung along the ceiling of Circular Quay station while the Rotogobos have been used to project the Asics logo onto the main escalators that lead up to the platforms.

Playing an integral part in the project were John A ten and Nobuyoshi Shoji, Account Executives for KWL Advertising who recommended Night-Shift Entertainment Services and the use of the lighting fixtures.

John said, "it's an entertaining and unique way of branding and the lights add movement and motion, complimenting the station and its surroundings. The lights are very versatile, colourful - and being able to customise them is the good thing about them. They are sure to catch on - there are already a lot of people, who have seen the display that are interested in using similar fixtures for promotions".

Night-Shift's technical team of Shannon Byrne and James Marmont found the installation process an experience in itself. To ensure that there were no disruptions to the daily schedule of the Station, the Night-Shift team worked in the early hours of the morning - from 10pm until 2am - to ensure the fixtures were working to their optimum performance.

The concept was unveiled in December last year at the international launch of a new range of shoes called the Gel Kayano. "Stadium Asics", as the project has been nicknamed, was on display at Circular Quay Railway Station from Dec 99 to Jan 2000 and then will return in July - August 2000, just before the 2000 Olympics.

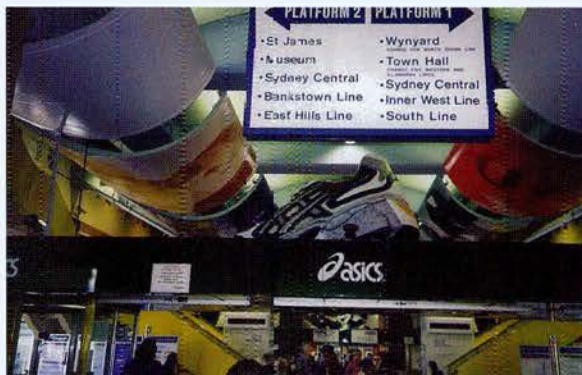

Lighting::PRODUCT COMPARISON

BY::John Grimshaw

manufacturer: **LSC**

desk: AXIOM 24/48

price (ex tax): Au\$3950

distributor: LSC LIGHTING SYSTEMS +61 3 9561 5255

No. of DMX Channels: 48

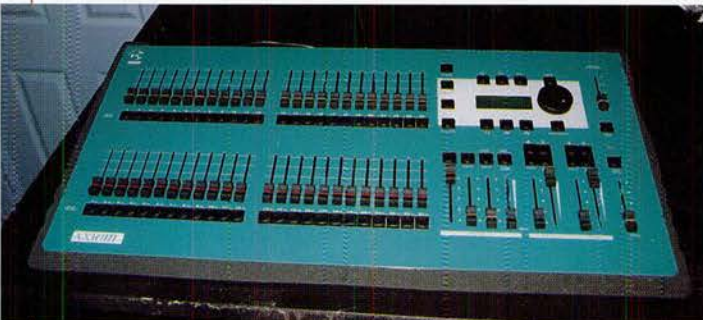

General Information

This is a basic, two preset type of desk - designed for small venue use. Ideally used as a 24 channel desk, an optional "wide" mode does give control over 48 channels.

Do you want manual fader control of individual channels?

This is the desk's primary type of interface, and the way it was designed to be used. The two rows of 24 faders give immediate access to channel control.

Do you want submasters?

The lower row of faders can be set to be submasters, with the ability to snapshot the output of the desk, record chases or "stacks" of cues. There are 12 pages of 24 submasters that can be recorded on this desk.

Do you want intelligent lighting control?

Believe it or not, this little desk does have some limited abilities in this area, including hexadecimal level (0-255) display for precise movement control, and a form of "tracking" recording that optionally allows the user to modify only the specified channels in a specific cue. This little guy even has a fixture library!

Do you want to run a sequence of preset cues in a generic "theatrical" situation?

Control in this way is achieved by using the "stack" method. A consecutive series of up to 99 cues are recorded into 1 of 48 stacks, all with individual times for each cue. The stacks can be linked to each other for seamless show running.

Do you want to run chases and other effects?

Up to 24 chases can be programmed into the memory. This is done in a similar fashion as "stacking", and there is the ability to set the step, fade and dwell times for the chase.

Do you want inexperienced operators to be able to immediately control the desk?

This desk is quick to operate at a basic level. The complex functions like "stacking" and chases will require much more time for anyone to understand and master.

Do you want to be able to archive or move the show information from desk to desk?

The desk is fitted with a floppy drive that uses PC formatted disks.

Do you want to be able to "offline edit" your show?

Not possible.

Do you want a video display?

Not available on the Axiom range.

Where is it repaired if a fault develops?

Service agents in most capital cities

continued over

Your 'One Stop' Rigging Shop.

At Hoisting Equipment Specialists, we have the most comprehensive range of rigging, lifting and materials handling equipment in Australia. As suppliers to the Entertainment Industry for more than 15 years, H.E.S. has the staff with the knowledge of your requirements. We understand you have deadlines and you will have peace of mind knowing your order will arrive on time, everytime.

We guarantee it!

"Hoisting Equipment Specialists" the name to remember for quality, service and advice, at the right price!

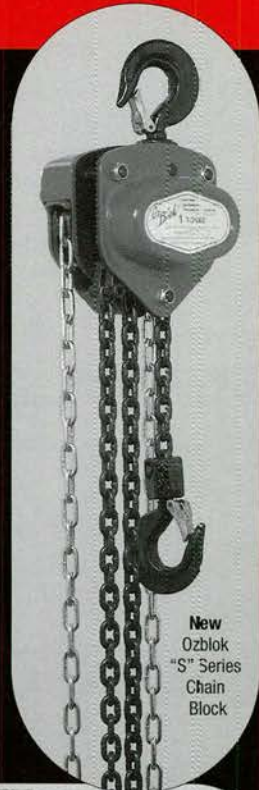

New Ozblok "S" Series Chain Block



Black Round Sling

- Ozblok range of products, including the new generation "S" Series chain blocks, girder clamps and trolleys.
- C.M. Lodestar, GIS, Kito and Hitachi chain motors.
- Galvanised and stainless steel wire rope and fittings.
- Standard wire and Superflex steels and bridles made to your requirements.
- Manual and electric winches.
- Extensive range of rigging hardware including rated shackles, rigging screws, eyebolts etc.
- Black polyester round slings.
- C.M. Stac chain.
- Height safety equipment and fall arrest systems.

Ozblok

- Industrial and recreational harnesses, carabiners, dynamic and static climbing ropes.
- Tri-lite pocket laser levels.
- Canvas chain bags.
- Bonwick caving ladders.
- Endless webbing ratchet straps and load restraint systems.
- Sisal and manilla rope.



HOISTING EQUIPMENT SPECIALISTS PTY. LTD.

12/63 Norman Street
Peakhurst NSW 2210
Phone: (02) 9584 1177
Fax: (02) 9584 1201
Email: HOISTEQUIP@bigpond.com

39 Raglan Street
Preston VIC 3072
Phone: (03) 9480 5577
Fax: (03) 9480 0855
Email: hesvic@ocean.com.au

Lighting::PRODUCT COMPARISON

BY::John Grimshaw

LSC

continued from previous page

Any other interesting features noted by the panel?

Small and light. Good for small venues, churches etc.

Any drawbacks noted by the panel?

Flash buttons are a bit too close together, so it is all too easy to mis-hit a button. A lack of video display output can be a serious limitation.

Other desks by this manufacturer

This is the smaller model in the Axiom range, the larger being a 36/72 @ \$5000. LSC also make the Atom range of mini desks, with the 12/24 @ \$1720, and 24/48 @ \$2750.

manufacturer: **LIGHTPROCESSOR**

desk: QCOMMANDER

price (ex tax): \$5487

distributor: GUET +61 2 9420 4888

No. of DMX Channels: 256 OUTPUT CHANNELS

General Information

This desk is primarily designed as an intelligent light control desk.

Do you want manual fader control of individual channels?

Not available with the desk tested.

Do you want submasters?

Physical faders and traditional submaster were not on the desk tested. However, it could record output "snapshots" which LightProcessor have called "groups". These can then be used in a similar fashion to submasters.

Do you want intelligent lighting control?

The desk has a large library of intelligent lights in an internal library. It is designed to operate up to 16 of these fixtures. Programming is very complex (see next question), but given time, these fixtures can be controlled quite precisely.

Do you want to run a sequence of preset cues in a generic "theatrical" situation?

This can be achieved, but it is a complex process. The following description of the steps required for programming one channel into a scene is given as an example: Using a sequence of menus, the user defines a scene number to be programmed, selects whether to add channels or a "group" to the scene, and then has a list of channels. The user moves the cursor up and down to

select a channel, and then uses the trackball to set the level from 0 to 255. These scenes can then have times attached and be played back in sequence.

Do you want to run chases and other effects?

This desk can record up to 64 chases, each with up to 64 steps. The step fade and dwell times can be set globally, or for each step.

Do you want inexperienced operators to be able to immediately control the desk?

This desk takes time to learn how to operate, as it does not follow any familiar way of programming desks.

Do you want to be able archive or move the show information from desk to desk?

This desk uses a PCMCIA type 1 card with 512kB of SRAM for backing up the desk, updating the system software, and updating the fixture library. Spare cards cost \$549 from GUET, but you will find better prices from your local computer supplier.

Do you want to be able to "offline edit" your show?

Not possible

Do you want a video display?

Not available with the desk tested.

Where is it repaired if a fault develops?

Brisbane

Any other interesting features noted by the panel?

Could be useful as a additional desk purely for controlling intelligent lights, or in clubs.

Any drawbacks noted by the panel?

Very complicated interface. The level control for each channel was displayed in its hexadecimal form, which makes finding percentage points of 255 positions a bit of a brain drain.

Other desks by this manufacturer

The Q Commander can be supplied with an "input extender" which adds 16 submaster type faders to the desk. LightProcessor also make a small 2 preset desk.



Colourset Series 2

Twenty-one colours.
MAKES A PAR LOOK
PRETTY SPECIAL!

COME AND SEE THE FRIENDLY STAFF OF
LOTS OF WATTS AT ENTECH STAND NUMBER L35

new products::

STRAND ARCHITECTIURAL SL

Strand Lighting's successful SL theatre range, which sold 15,000 units inside six months of production, has expanded with the announcement of a new series dedicated to the Architectural market.

The new spotlights house metal halide 150W CDM lamps that combine performance, energy savings and long lamp life to create a source for display applications. Available in all standard SL beam angles, the range can be supplied in black, architectural white and grey RAL9006. Any other colour can be specified for quantity orders.

The CDM series lamps are available in two colour temperatures - 3000° for a warm, tungsten look and 4000° for a cool, daylight appearance.

All lamps feature high CRI indexes and all units are supplied with detachable electronic ballast. The full range includes six fixed-angle fixtures - SL5, SL10, SL19, SL26, SL36, SL50 - as well as two zooms, the SL15/32 and SL23/50.

Australian distributor.

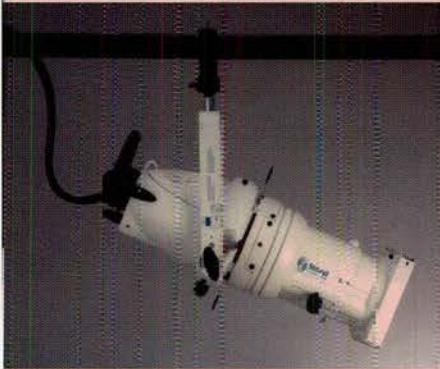

Bytecraft + 61 3 9587 2555, 2 9550 3955.

LSC E-24 and ePRO

LSC Lighting Systems have launched the E-24 Touring Dimmer System complete with 24 channels of 12 Amps connected through a 2:1 series/parallel patch bay, it offers 48 or 60 outputs, depending on the connector arrangement.

With a selection of Weiland/Harting or Socapex output connectors,

the E-24 is available in four models. Each of which offer full Earth Leakage protection on inputs and auxiliary output connectors for powering ancillary equipment.

Fully flight-cased with front and rear lids with wheels, the E-24's compact size is ideal for quick set up of shows and transportation.

Also new from LSC Lighting Systems is the ePRC 12 Amp Professional Dimmer Pack

LSC +61 3 9561 5255.

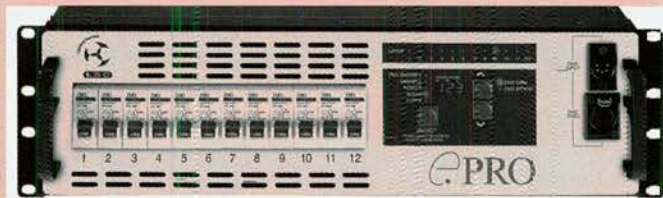

CP-100

The OS update to V3.0 for the CP-100 Universal Lighting Console brings several new features including User Definable Fixtures function (UDF) enabling the user to produce custom defined fixtures for the CP-100's Universal Fixture Library on a computer using a standard text editor.

The second notable feature addition is the implementation of "Special Effects" which acts as an automatic special effect generator for any fixture's DMX channel(s). Effects such as "circles", "figure 8s", "ballyhoos", and "rainbows" can be created easily and recalled at the touch of a button.

Also new is the CP-100 Submaster Expansion Wing which gives the user an additional 12 playback and 12 Dimmer Submaster Fades as well as the OS v3.0 software update. This bolt-on unit can be purchased with the new CP-100xt Universal Lighting Console or added to any existing CP-100.

Call: Show Technology +61 2 9898 1111

Innovative, affordable, easy to use. Object-based CAD used by design professionals around the world.

VectorWorks seamlessly integrates object based design with precision 2D drafting, powerful 3D modelling and high-quality rendering. Creating increased productivity of object based design, without sacrificing the flexible and control offered by general purpose CAD. Couple this with specific tools, spreadsheet functions, a powerful scripting language and cross platform compatibility.

VectorWorks can simplify your daily tasks and enhance your overall productivity.

From only \$1600.00

MiniCAD®
Vector
WORKS
Object-Based CAD for Professionals
Windows®/Macintosh®



Image rendered
with RenderWorks

OzCAD Pty Limited
Free Call 1300 788 820
Web: www.ozcad.com.au
Email: sales@ozcad.com.au

**PACIFIC PROJECTION:
How COOL?
THIS COOL!**

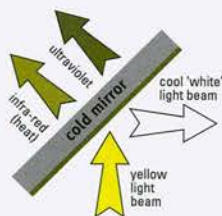

A NEW WORLD OF LOW COST DIY PROJECTION made possible by the superior properties of the Pacific flat cold mirror.

Images made in a computer program such as PhotoShop™ then printed onto plastic overhead transparency film by a colour inkjet printer can be used for several hours in the Pacifics. Care needs to be taken with the setup to maximise the life of the image—refer to our web page for full details.

For the **NEW YEAR'S EVE CONCERT** at the Sydney Domain, set designer Peter England discovered that with little budget, Pacifics not only provided a cost effective option, but also provided a level of flexibility that was able to accommodate last minute changes to the images with minimum hassle.

The **SYDNEY FESTIVAL** also used Pacifics to project this year's version of their logo on the Domain tent. 12°–28° Pacifics from the FOH tower (90–100m throw) covered the front of the canopy, while 90° Pacifics covered the P & OP sides of the canopy.

The **JAZZ IN THE DOMAIN** concert this year was in memory of Sydney Jazz great Roger Frampton, so an image of Roger in action with a time line was projected behind the performers. The production team was greatly impressed with the speed and ease of projecting the images using Pacifics.

AUSTRALIAN OPERA'S outdoor production of *La Boheme* staged in the Domain above Sydney Harbour is another annual Festival highlight. Lighting Designer Toby Sewell was looking for a tree gobo that would be a reasonable facsimile of one of the main images used in the Opera. Toby was unaware of the Pacific's abilities as a projector, and was delighted with the result of a quick e-mail from the Set Designer (Phillip Drake), who draughted the six gobos for projecting onto the canopy.

The latest in a continuing range of those making use of the plastic transparency 'gobo' capability of the Pacific is the **AUSTRALIAN MUSEUM** with the *Body Art* exhibition—Pacifics and transparencies are being used to project various tattoo images onto mannequins.

COOL, TOTALLY!

CONTACT YOUR SELECON DEALER OR SELECON FOR FULL DETAILS

- NSW** — HERKES PRO LIGHTING, Ph 02-9319 3133, Fax 02-9319 0204
- VIC** — CLEARLIGHT SHOWS PTY, Ph 03-9553 1688, Fax 03-9553 4401
- SA** — OSMOND ELECTRONICS, Ph 08-8410 1111, Fax 08-8410 3322
- QLD** — THE PRODUCTION SHOP, Ph 07-3216 1340, Fax 07-3216 1376
- ACT** — SOUND ADVICE, Ph 02-6280 8777, Fax 02-6280 8177
- WA** — STAGE & STUDIO, Ph 08-9227 9932, Fax 08-9227 9347
- TAS** — K.W.McCULLOCH, Ph 03-6343 1034, Fax 03-6343 1847

SELECON AUSTRALIA — Ph/Fax 02-9664 8237

E-MAIL: seleconaus@ozemail.com.au HOME PAGE: www.seleconlight.com

Lighting::PRODUCT COMPARISON

BY::John Grimshaw

manufacturer: **THEATRELIGHT**

desk: CUEMASTER 120 PLUS

price (ex tax): \$6,995

distributor: LIGHTMOVES TECHNOLOGIES PTY LTD +61 2 9560 0000

No. of DMX Channels: 120

General Information

General purpose desk with manual and memory control

Do you want manual fader control of individual channels?

The Theatrelight range of desks often provide a manual fader for each channel that the desk can control. With 120 channels, the Cuemaster 120 is a very big desk.

Do you want submasters?

There are 10 pages of 24 submasters - 240 total. As well as each being able to recall a "state", numerous "states" can be stacked into each sub, which can then be used as a chase or as a sequence of theatrical show cues.

Do you want intelligent lighting control?

While the Theatrelight could conceivably control intelligent lights, it is not really designed to do so. As a result, it is difficult to program movement sequences.

Do you want to run a sequence of preset cues in a generic "theatrical" situation?

This desk offers the basic features required to run a show in this way. However, there are numerous limitations, which is why this desk is not often seen in professional "theatrical" venues.

Do you want to run chases and other effects?

As mentioned previously, this is done using the submasters. Separate fade and dwell times can be recorded globally for each chase

Do you want inexperienced operators to be able to immediately control the desk?

Given a little time to understand the interface, an inexperienced operator could operate this desk. Theatrelight have printed numerous helpful instructions on the front panel of the desk to facilitate this.

Do you want to be able archive or move the show information from desk to desk?

This desk uses a memory card for saving the desk. Unfortunately, this means that the number of memory cards you have defines the number shows you can save, and at \$155 ea, that can become an expensive option. However, the desk documentation indicates that the memory in the desk lasts five years without power, and crashes happen very rarely if at all.

Do you want to be able to "offline edit" your show?

Not possible

Do you want a video display?

There is a video output for the desk that gives the user a display of the current channel output as well as some other useful data.



Where is it repaired if a fault develops?

Most capital cities and some other large centres.

Any other interesting features noted by the panel?

The "plus" version of the desk includes a panel known as DMX Link. This novel little gadget (which can also be purchased separately) can mix two streams of DMX to one output, load any of four soft patch lists, it has 10 pages of 10 submasters and 4 separate analogue controls (for houselights). This device is limited to controlling 240 channels.

Any drawbacks noted by the panel?

The layout and operation of this desk is unlike any other desk. As a result, some operators that have learned other desks may consider the ergonomics and operation of the desk a bit difficult to work with.

Other desks by this manufacturer

This is the top of the range model of the Cuemaster series. There are numerous smaller and simpler desks that are progressively cheaper, all the way down to the baby Starlette 6 @ \$345.

LIVING THE HIGH LIFE

lighting designer Allan Parkinson in demand on the party circuit

Allan Parkinson has been a well known figure in the mid-night-world of nightclubs and dance parties for several years, gaining a reputation as a competent and innovative lighting designer particularly on the gay scene.

In the past few months, since Allan returned to Sydney from Melbourne, his career has sky-rocketed. Most Saturday nights he is the resident lighting director at ARQ nightclub, a job which pays well and leaves him plenty of free time to pursue other projects.

Prior to Christmas Allan worked on the lighting design for the nightclub GAS in Sydney and he is currently designing the new nightclub/live venue which will open at Fox Studios later in the year. Allan also co-designed the lighting for the launch of Fox Studios last year with Francesco Calvi.

Allan is planning to use quite a bit of projection work in the new Fox Studios nightclub.

"I've got a couple of ideas up my sleeve," he said. "I want to put a couple of large projectors in there to use as a light source as well as the moving lights."

Dance parties are as popular as ever and Allan is probably the top choice lighting designer in this country for such events. He recently did the Sleaze Ball in Sydney, the Sydney Lesbian & Gay Community Centre "PRIDE New Years Eve Party 1999" at the Hordern Pavilion, and the Melbourne Australia Day Red Raw Party produced by the ALSO Foundation and held at Shed 14, Victoria Dock. Allan designed the lighting for last year's Mardi Gras party in the RHI and he is currently working on this year's design, again at the RHI but also incorporating the stage area.

"Usually there has been two separate designers but this year they want me to do the same room which is fantastic," said Allan.

Through his work on the Mardi Gras and Sleaze Ball Allan has found himself in demand on the American gay dance party scene.

"Promoters saw what I did and they wanted to take a talent back to America because basically there was no one else in America achieving that standard," said Allan. "As big as America is, there party scene was much smaller. Their production was nowhere as good as ours. In the last six months I've lit the Hell Ball (a Halloween ball in San Francisco) in October, the Magnitude party in September, and I was in New York in August doing a large party on Fire Island.

"Earlier in the year I did the White Party in Palm Springs, the Black Party in New York in March....it's just a string of parties month after month. This year I've already been contracted to do all the same parties and the first one is the White Party in New York's Roselands Ballroom next week! It's been fantastic for me especially as I have projected work for the next twelve months. The parties are getting bigger as are the productions.

"Working in America is getting easier, at first it was quite difficult. In fact it was a nightmare and I hated it! The power is different, their terms are different and back in Australia I have a team of people who have put me where I am including Ian Messner and Michael Kent. When I first went to America those people weren't there and I found that hard. Now I've got contacts throughout the West and East coast and I have good people who know exactly what I'm all about."

One job Allan did in the US which he is particularly proud of is

continued over



Mardi Gras

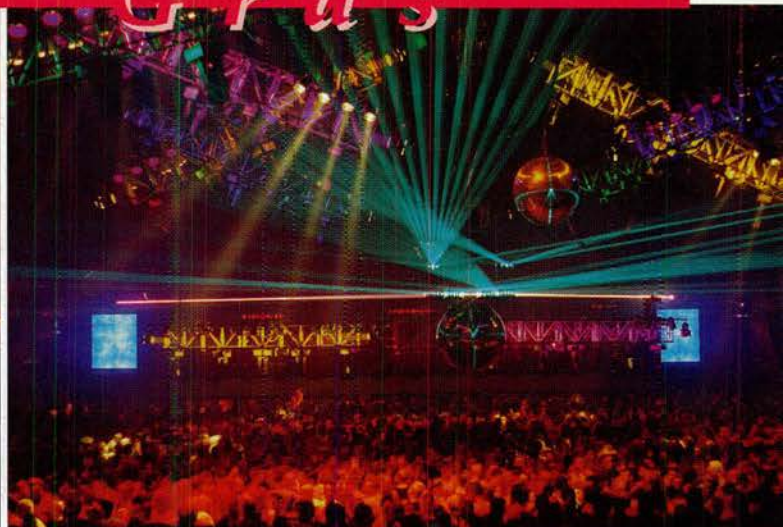
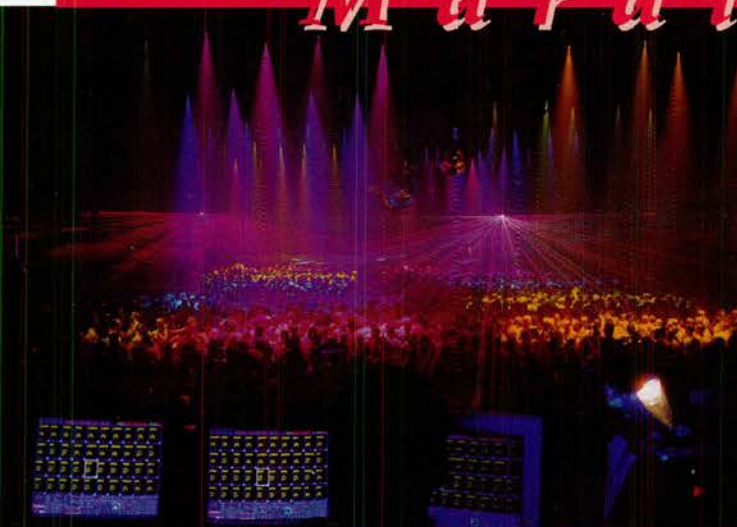

Mardi Gras photos courtesy of Oracle Laser

LIVING THE HIGH LIFE *continued from previous page*

the lighting of the San Francisco City Hall building during the Gay Pride week.

"It had just been renovated at a cost of \$230 million and I was the first person to light it," Allan said. "The mayor gave me special approval to turn the building hot pink for the whole week! I've got another event coming up called the Sydney Harbour Party

which will be held at Lady Macquaries Chair on the botanical side. It's a tea dance the Sunday before the Mardi Gras parade. I've been contracted to light the peripheral area of the party, mainly the trees. I'm excited about doing that, it's something different. 3200 Lighting are supplying the gear and lighting the dance floor area. I'll turn the site into a bit of a fairy land between 9pm and 12am using projected images on the trees, several 8-lite's with Colourmags, hopefully the new Cyberlight Turbo's, and some Arena Visions with the congo-blue gel glass in them to light the night sky. Oracle are supplying a 10W laser. There's definitely a future in lighting buildings and sites."

One of the most interesting jobs Allan has done recently is the lighting of the yacht used by Tom Cruise, Nicole Kidman, Sarah O'Hare, Lachlan Murdoch, Baz Luhrman and Catherine Martin for their private New Years Eve party.

"Absolutely every bit of gear was bought on to the boat which was transformed into a 'boat which had sailed the seas for over 2000 years' and been through every port of origin," Allan described. "The cabins were totally over-designed and decorated by Tony Asness from Synch who employed me. I had to scenically set the mood on the boat, it was far from just a dance floor. I wish I had photos but no one was allowed to take any."

Allan is still a big fan of Vari*lates, the moving light he feels most at ease with.

"However I'm getting my head around desks like the Echelon so it's making it easier to use other moving lights," Allan said. "I still favour the Vari*lite and I'm still waiting to bite into the VL7. I've been promised them but...."

"I've used Martin MAC's quite a lot during the past six months in the nightclubs but I have a good relationship with Jands Production Services. Dance parties are really just an extended version of a nightclub, it's a dance hall but five times the size. The nightclub design has been a new thing for me. When Ian Messner and I walked into GAS nightclub it was just a concrete shell. I told Ian what I wanted to achieve there but we had to engineer a mother grid to hang everything from. We went from nothing to being able to hang 5 tonnes of weight. Again, with the new nightclub at Fox, we just have a shell to start with. If you go into the RHI, you have the same rigging points already there for every party. You have to create that in a nightclub which is much harder."

Allan sees the nightclub and dance party scene in Australia growing bigger and bigger.

"Since ARQ opened up it has inspired every hokey-pokey nightclub in Sydney to totally renovate and turn into multi-million dollar nightclubs," he stressed. "There's a market out there, people always want to listen to music. I think the nightclub-slash-live venue concept is where the market will go. When the Fox Studios nightclub is not in nightclub mode there will be new promotions, theatre, live music - multi-purpose events. The multi-purpose venue is what's going to happen in Australia. That was the main thing behind ARQ and GAS. The day of the nightclub is over."

"My career has changed so much in the past six months," reflected Allan. "Sometimes I wonder where it is going. Every day it changes - dance parties, corporate work, private parties. I'd really love to do a big rock'n'roll show! I'd also like to do some television work, doing Fox Studios was an eye opener. There was a lot of bitching going on and we coined the phrase 'saucer of milk to table thirteen, meow'. I thoroughly enjoyed working with

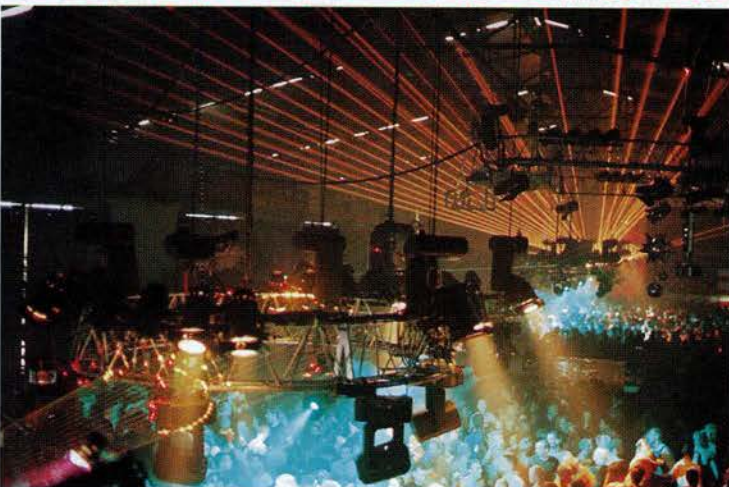
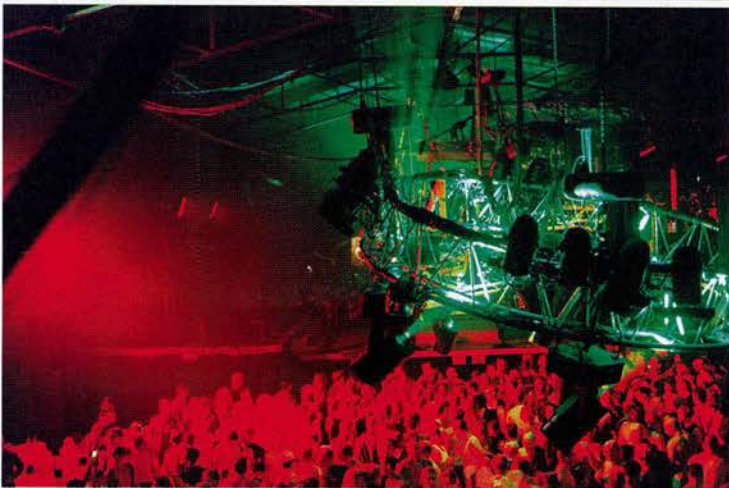

Lighting::PROFILE

BY::Cat Forcer

Francesco Calvi, I adore him. He's one of Australia's finest men and it's been a god send meeting him. Another great person who's helped my career is Mark Hammer, he programmed Pride New Years Eve for me and he's very understanding of what I want to achieve. I'd also like to mention the support that Ian Messner and Michael Kent have given me"

"It feels like all the hard years doing all the late nights and dance parties have paid off."



Pride

Pride photos courtesy of Dominique Cleary

RYGER

THE TINY SCAN SYSTEM
THE AX4 CHASER

DISCO WORLD PTY LTD

SHOWROOM: Factory 20, Cave Hill Road, Lilydale VIC 3140

Ph 03 9735 0588 Fax 03 9739 5441

Web: www.discoworld.com.au

Email info@discoworld.com.au

VisioSonic



THE ULTIMATE
LIVE PERFORMANCE
TOOLS FOR PRO DJ'S
DIGITAL 1200SL



ENTECH STAND E16

Connections Advertiser & Product EASYFINDER!

*Please.... tell
them you saw it
in Connections!*

Company Name	Phone Number	Website address	Product	Page
AC Lighting	+44 1494 44 6000	www.aclighting.co.uk	Chroma-Q	99
AC Lighting	+44 1494 44 6000	www.aclighting.co.uk	Vision Parshell	101
AC Lighting	+44 1494 44 6000	www.aclighting.co.uk	Wysiwig	103
Acoustic Answers	+61 2 4736 7723		Sonex	32
Acoustic Technologies	+61 7 3376 4122	www.acoustic-tech.com.au	Acoustic Technologies	31
Acoustic Technologies	+61 7 3376 4122	www.acoustic-tech.com.au	Radian	75
Active Lighting	+61 3 9819 6912		Hire & Production Directory	60
Amber Technology	+61 2 9975 1211	www.ambertech.com.au	TC Electronics	37
Amphenol Australia	+61 3 8796 8888	www.amphenolaust.com.au	Amphenol	77
AON Risk Services	+61 2 9253 7000	www.aonrisk.com.au	Entertainment Insurance	78
Apple Computers	133 622	www.apple.com.au	Apple Computers	58,59
Audio Telex Communications	+61 2 9647 1411	www.audiotelex.com	Peavey	29
ARX	+61 3 9555 7859	www.arx.com.au	Various at Entech	79
audiovisualshop.com	+61 2 9554 5310	www.audiovisualshop.com	Website	26
AV Communications	+61 8 9249 6688	www.avcom.com.au	AVC	43
AWA	+61 2 9669 3477	www.audioproducts.com.au	Jeil	43
Big Beat Productions t/as Johnston Audio	+61 3 9329 3311	www.johnstonaudioservices.com	Hire & Production Directory	62
Birkart Concert Cargo	+61 3 9696 2988	www.birkart.com	Transport & Logistics	83
Browns Precision Engineering	+61 3 9455 2899		Truss Manufacturing	104
Bytecraft	+61 3 9587 2555	www.bytecraft.com.au	Bytecraft Generic	63
Central Musical Instruments	+61 3 9315 2244	www.cmi.com.au	Apogee	23
Central Musical Instruments	+61 3 9315 2244	www.cmi.com.au	Eminence/Prøel	41
Central Musical Instruments	+61 3 9315 2244	www.cmi.com.au	Various at Entech	45
Concert Corporate Productions	+61 8 9328 9529	www.iinet.net.au/~ccp	Hire & Production Directory	65
Concert Lighting Systems	+61 3 9682 6111	www.clsacom.au	CLS	51
Corporate Audio Services	+61 3 9480 5980	www.corporateaudio.com.au	Audient	18
Digidesign	+61 3 5428 7780	www.digidesign.com	Digi01	21
Disco World	+61 3 9735 0588	www.discoworld.com.au	Gemini	93
Disco World	+61 3 9735 0588	www.discoworld.com.au	Dynamite	106
Disco World	+61 3 9735 0588	www.discoworld.com.au	Ryger/Visiosonic	113
EAW	+61 3 9415 1585	www.eaw.com	EAW Avalon	35
Electric Sunshine	+61 2 9550 6000	www.electricsunshine.com.au	Hire & Production Directory	50
Emtec Magnetics	1800 805 691	www.emtec-magnetics.com	BASF Tracking Guide	44-46
Entertainment Product Services	+61 2 9898 0501	www.omnitronic.com.au	Various	34
EVI Audio	+61 2 9648 3455	www.eviaudio.com.au	EV	17
GUET	+61 2 9420 4888	www.guet.com.au	Celestion	33
GUET	+61 2 9420 4888	www.guet.com.au	StuDiomaster	115
H&C Audio	+61 3 9876 2333	www.ozemail.com.au/~hcaudio	Wavecom	42
Hire & Rental Association	+61 7 3851 4777	www.hireandrental.com.au	Hire & Production Directory	51
Hoisting Equipment Specialists	+61 2 9584 1177		Ozblock	107
Interlink System Solutions	+61 2 9638 0777		Interlink System Solutions	32
Jands	+61 2 9582 0909	www.jands.com.au	Shure	2
Jands	+61 2 9582 0909	www.jands.com.au	JBL	3
Jands	+61 2 9582 0909	www.jands.com.au	dbx	81
Lots of Watts	+61 2 9638 0302		New Showroom Opening Sale	22
Magna Systems & Engineering	+61 2 9417 1111	www.magnasys.com.au	DAS	39
Major Music Wholesale	+61 2 9545 3540	www.majormusic.com.au	Electric	39
Martin Professional Lighting Aust.	+61 2 9698 3009	www.showtech.com.au	Martin MiniMac	97
Miller Professional	+61 2 9439 6377	www.miller.com.au	Brightline, Lowel, Avenger	105
National Systems Corp Australia	+61 3 9434 1888	www.chaiyo.com.tw	Various	28
Navigator Systems UK	+44 7000 628 797	www.navigator.co.uk	HireTrack	84
Oceana Audio	+61 3 9362 0699		Hire & Production Directory	61
Ozcad	+61 2 8338 8622	www.ozcad.com.au	Minicad/Vectorworks	109
PA Stuff Pty Ltd	+61 2 9838 4622	www.pastuff.com	www.pastuff.com	46
Panasonic	+61 2 9986 7400	www.panasonic.com.au	Panasonic Projectors	15
Penn Fabrication	+61 3 9335 6455	www.penn-fabrication.com.au	MSB	36
Presentech	1800 635 514	www.presentech.com.au	Presentech Magazine	6
Production Audio Services	+61 3 9415 1585	www.productionaudio.com.au	Crest	25
Production Shop	+61 7 3216 1340	www.productionsshop.com.au	Hire & Production Directory	56
Public Event Group	+61 2 8585 5200	www.publicevent.com	Stageline	44
Richardson & Devine	+61 7 3252 4433	www.meyersound.com	Meyer Sound	4
Richardson & Devine	+61 7 3252 4433	www.meyersound.com	Meyer Sound	5
Roland Corporation	+61 2 9982 8266	www.roland.com	V-Mixing System	8
SAE	+61 2 9211 3711	www.sae.edu.au	SAE Courses	71
Selecon	+61 2 9664 8237	www.selecon.co.nz	Selecon	110
SGM Light Technology	+39 721 476 477	www.sgm.it	SGM	95
Showcraft	+61 2 9698 3009		Showcraft Co ourset	108
Show Lighting Australia	+61 2 9898 1111	www.showtech.com.au	Clay Paky	116
Stage & Screen	+61 2 9383 4544	www.stageandscreen.com	Travel & Freight	14
Studio Supplies	+61 2 9957 5389		DPA	75
TAG Technical Audio Group	+61 29810 5300	www.tag.au.com	Martin Audio	19
The Music Box	+6 12 9797 1800	www.themusicbox.com	Speaker Hospital	76
The Resource Corporation	+61 3 9877 8233	www.trc.com.au	K&M	75
The Resource Corporation	+61 3 9877 8233	www.trc.com.au	SC Staging	76
The Resource Corporation	+61 3 9877 8233	www.trc.com.au	Eurocable	78
Trader	1800 635 514	www.conpub.com.au	Trader	86-89
Universal Lighting and Audio	+61 7 5532 9922	www.ula.com.au	ULA Lighting Product Port Folio	90
Yamaha	+61 3 9693 5111	www.yamaha.co.jp/product/	Yamaha Mixers	27

StuDiomaster Club 2000 series

HI Z PLUS

Based on the proven design concepts of our most expensive mixing consoles, the Club 2000 range delivers a remarkable level of features and versatility that is unmatched by other compact mixers.

With our new HI Z input circuitry, the Club 2000 range offers greater flexibility. The line inputs accept any signal from CD players to electric guitars - no more guess work.

102 - 6 mic/2 stereo rackmountable
142 - 10 mic/2 stereo rackmountable
182 - 14 mic/2 stereo

- Balanced mic & line inputs.
- 3 band EQ with Mid Sweep.
- 2 Aux sends.
- Listen (PFL).
- Stereo Aux return.
- 48V Phantom power.
- Balanced outputs.
- Internal power supply.
- 60mm faders.
- Internally modular.
- Optional rackmount kit available for 102 and 142.



The Club DSP offers a superb audio specification together with well chosen features and a high quality 32 bit digital stereo effects processor in a compact package that will last for years.

Club 2000 DSP

6 mic/2 stereo rackmountable

- 32 bit digital effects processor.
- Balanced mic & line inputs.
- 3 band EQ with Mid Sweep.
- 2 Aux sends.
- Listen (PFL).
- Stereo Aux return.
- 48V Phantom power.
- Balanced outputs.
- Internal power supply.
- 60mm faders.
- Internally modular.
- Optional rackmount kit available.

Built to last!

All models use traditional construction methods with an internally modular design, rugged 18 gauge steel chassis and fully regulated internal power supply.



Applications:

- Solo singers & entertainers • Public address • Duo's & bands
- Karaoke • Theatres • Installations • Conferences • Clubs & pubs
- Bars & restaurants • Schools & colleges • Places of worship • Recording
- Computer soundcards • Video audio • DJ mixing • Keyboards

StuDiomaster - because you can't

In accordance with our policy of progressive product development, StuDiomaster reserve the right to change features and specifications without prior notice.

Distributed by GUET SVL Distribution
87 Mars Road, Lane Cove 2066
Ph: (02) 9418 6029 Fax: (02) 9418 9801
Email: mardelle_collins@guet.com.au

GREATER UNION
ENTERTAINMENT TECHNOLOGY

The winner is... Stage Line



STAGE LINE
1999 LIVE! AWARDS
New Lighting Fixture
of the Year



STAGE LINE
1999 ETA AWARDS
Club Lighting Effect

STAGE COLOR 300
1999 ETA AWARDS
Budget Lighting Effect



STAGE LINE
1999 MOLSON BEA AWARDS
The New Product of The Year



STAGE LINE
1998 EDDY AWARD
The Art and Technology of
Show Business



STAGE LINE
1998 ETA AWARDS
Innovative Lighting Product

Distributor:

SHOW LIGHTING AUSTRALIA Pty Ltd

Adm. Office: 13-15 Bridge Street - Rydalmere NSW 2116 - PO Box 480 Rydalmere NSW 1701
Tel. +61 (0) 29898 1666 - Fax +61 (0) 29893 1222 - E-mail: showtech@showtech.com.au

CLAY PAKY S.p.A.

Via Pascoli, 1 - 24066 Pedrengo (BG) Italy
Tel. +39-035-654311 - Fax +39-035-665976
Internet: www.claypaky.it



PROFESSIONAL SHOW LIGHTING