

Connections

The **Entertainment Technology** Magazine

July 2000 A\$5.50 (inc GST)

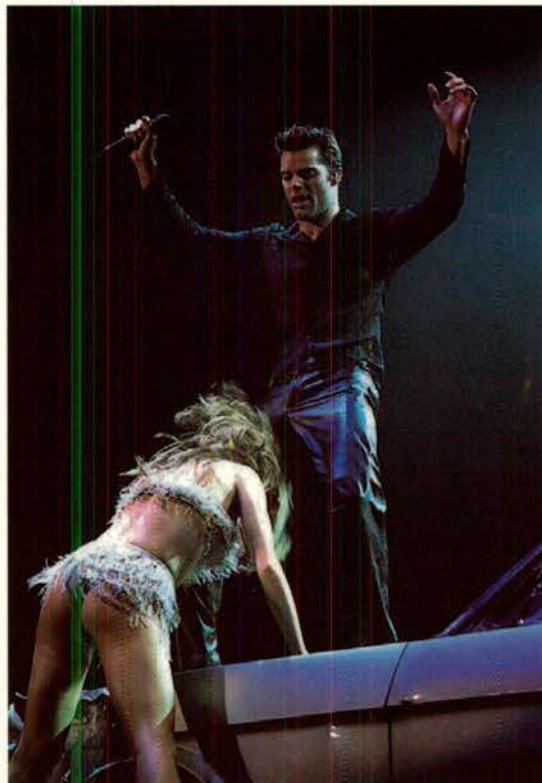

SHAKE YOUR BON BON!
Ricky Martin is coming, and the production values are terrific!

GET INSPIRED!
Slava makes compelling theatre with old tricks and new cred!

HOTTEST SHOWS!

- WE FIND THE NEWEST AND BEST PROJECTORS - AV EXCLUSIVE!
- ROYALTY BATTLE WON IN COURT: LESSONS FOR THE STUDIO
- WHICH FRICKEN LAMP? WE DETAIL WHICH GOES IN WHAT
- PLENTY OF PA, STUDIO AND INSTALL AUDIO, LOTS OF LIGHTS

ISSN 1320-5595



08

9 771320 559004

Now incorporating **PRESENTech**

**You Love Them
For Their Live
Performance.**

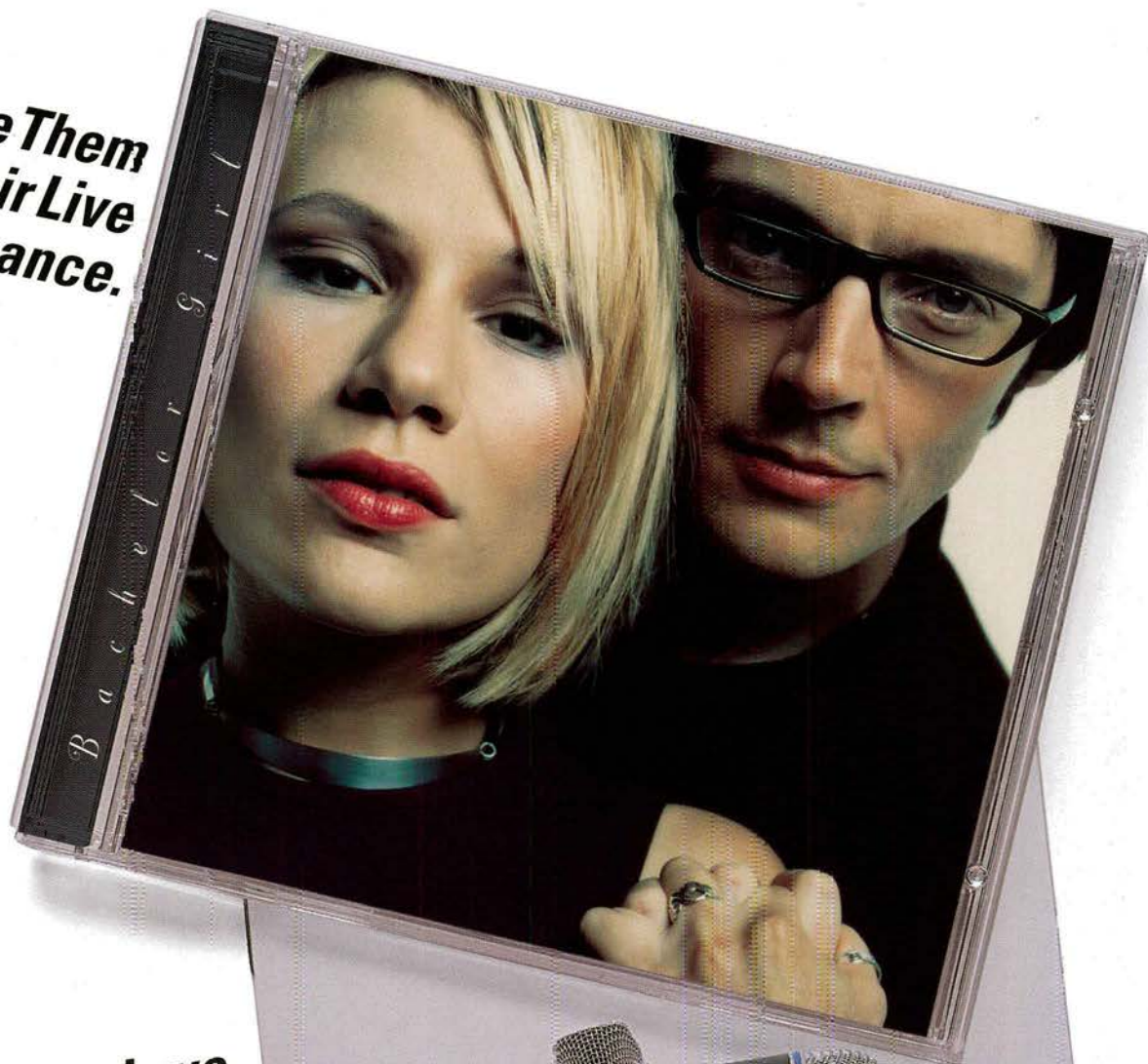

**They Love
Shure
Beta Microphones
For The Same
Reason.**



SHURE®

Distributed in Australia by:
JANDS Electronics Pty Ltd
40 Kent Road Mascot NSW 2020
Phone: (02) 9582 0909
Fax: (02) 9582 0999

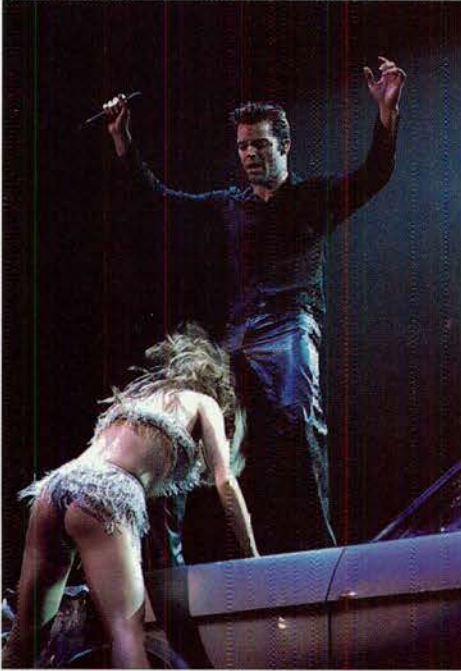

"From the moment he burst on to the stage in a battered, 65 Mustang, Martin shook his tight leather-trousered ass for all it was worth. And, like a man whose crotch is being besieged by a pack of hungry ferrets, he doesn't stop".

Go to page 42!

Snow Show: probably the best thing you'll see in a theatre for a long, long time.

Go to page 67



Inside your news magazine:

Venues fight to the death (there are too many!) Sydney to say goodbye to Her Majesty's as Casino bites	5
Royalty battle won in court. John Prior tastes victory Tips for young players: be sure to register your song!	5
Shootout: we pick the best new projectors, at the LA show We fearlessly choose the best from all the categories. Read on.....	8
Life after the Olympics not so happy	9
Mackie introduce first new desk of its kind in four years	10
New AV trends emerge at Infocomm	10
Pioneer go PLASMA in a big way	16
More rock, less cafe as Hard Rock Cafe goes Turbo for the bands	18
Renkus Heinz returns to Australia	20
101 Collins street: anatomy of a big outdoor lighting job	22
Flashram recorder: new	26
Pani film scroller	28
Peavey debut new Cobranet devices	28
LSC announce iPro is shipping	28
Crank up the volume! PA at the Soccer	32
Ricky Martin! This is one show to see! We preview the tour in London	42
A lamp is a lamp - right? Wrong!	48
Piaf plays to packed houses	52
NZ Report	52
Water powered searchlights: how to make them!	55
Big Gig: how Hyundai launch their range.	56
Women in the industry	60
Rigging	61
Colonial Stadium: the PA works as advertised.	62
Things the books don't tell you. Graham Walne	64
How to do it: Live sound series	66
Slava's Snow Snow: winter hit	67
Black Inc Studio goes Artemis	71
Studio News	73
BASF Tracking Guide	73
Duncan Fry	78

Filled with people talking about their shows, sessions and work - and what they use!

World's easiest subscriptions!

Au \$52 1 yr*
 Au \$86 2 yrs*
NEW ZED:
 Au \$80 1 yr
 Au \$120 2 yrs
ASIA:
 Au \$80 1 yr
 Au \$140 2 yrs
USA:
 Au \$115 1 yr
 Au \$199 2 yr
EURO:
 Au \$125 1 yr
 Au \$240 2 yr
 *Incl. GST

- Step one. Decide to save 25% or more.
 Step two. You want your mag early, before the newsagent.
 Step three. You know we are very trusted to do this right!
- 3 VERY EASY WAYS TO SUBSCRIBE:**
- (A) Use our online form at www.conpub.com.au ; or -
 - (b) Fill out the stuff on the right. and fax it to us ; or -
 - (C) Call Sarah on 1-800-635-514 in business hours.

I want to subscribe NOW! Yeah! quickquickquick.....

Dearest Sarah, please call me during work hours and fix this up:

My name is: _____

Work phone: (incl country code) _____

OR, my email address: _____

OR, fax me a form to this fax: _____

FAX THIS PAGE TO **+61 2 9876-5715**, Sarah will be in touch!

UNRIVALED PERFORMANCE!

Unrivaled Product Selection.

No other professional speaker series offers you as many choices. With 18 unique speaker designs, there's an SR-X System that's just right for your musical and personal style.

Unrivaled Reliability.

With the highest sensitivity and lowest power compression in their class, all SR-X Series speakers play louder longer.

Unrivaled Build Quality.

Their 13-ply baltic birch cabinets, virtually indestructible DuraFlex™ finish and tongue and groove construction are just a few of the reasons your SR-X system will gracefully shrug off the effects of life on the road.

Unrivaled Testing Ensures You of Unrivaled Satisfaction.

No other comparable system is tested like an SR-X. While most manufacturers test their speakers for only a few minutes, each SR-X design is tested for 100 hours at rated power output. This subjects SR-X to more strain and stress than they would typically experience in years of actual use! It's a JBL commitment that assures you unparalleled confidence and satisfaction.

Unrivaled JBL Technical Superiority.

Pure Titanium Diaphragm Compression Drivers in all two-way and three-way models assures you of superior power handling and reliability. **VGC™ Vented Gap Cooling** means transducers that control heat build-up. The result: increased power handling and decreased power compression. **Dual Mode Crossovers** provide total system flexibility. Switch from full-range to bi-amplified operation smoothly and effortlessly. **Optimized Aperture™ Horns** feature driver exit and throat flare that integrate seamlessly. As a result, SR-X Series speakers minimize throat distortion and provide smooth frequency response, even at the highest SPLs.

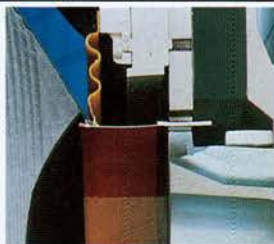

SR-X series



Add it all up, and you'll know why **9 out of 10** speaker systems travelling with today's top touring artists feature:

JBL's Concert Proven Components



A Harman International Company

Connections

The Asia/Pacific Entertainment Technology Monthly **JULY 2000**

Venue glut hits Theatres, Superdome

.... as Sydney's Casino kills off Her Majesty's Theatre

Suddenly there are far too many venues in Sydney, where for years the conventional wisdom was that more were needed. They were built, and now the venue business is anything but profitable.

To underscore this, Her Majesty's Theatre is to close next year, once current obligations are met. Theatre manager Jim Crowley said that Star City Casino was the main cause, where both the 2000 seat Lyric Theatre and the 800 seat Showroom were aggressively competing for shows.

Still more new theatres are scheduled for Sydney, including the new Parade Theatre at NIDA (800 seats) and a proposed 1000 seater for Sydney Theatre Company at Walsh Bay. Sydney's Luna Park also may acquire a theatre space, with plans advanced by the

new leaseholders, a partnership between Michael Edgely and the operators of Sydney's successful Metro venue.

Her Majesty's has been dark for 33 months during the past five and a half years.

Ominously, Mr. Crowley echoed fears that reach Connections' ears more and more often, whether from theatre, music or cinema sources. "There is a lack of new shows coming through" he says. Which belies the notion that 'if you build it, they will come'. You need material - or software - to fuel the hardware.

Then there's Sydney's Super Dome, the 20,000 seat arena venue at Homebush Bay. Once the Olympics are over, this venue will return to its current state - mainly dark. It has hosted few shows since opening last year.

• Homebush Bay troubles: Page 9

Royalty battle settled in court

He wrote the music in 1992, and a court awarded his royalties in 2000. John Prior urges music composition status be agreed in the studio, once any song is committed to tape

Sydney based composer, musician and producer John Prior won a crucial copyright case in the Federal Court of Australia recently. He sued Zelda and Stuart Sheldon, and Artec Sound Vision Productions, over denial of royalty payments for the theme music used on the Network 7 show; *The Great Outdoors*. The court found that although the Sheldon's claimed the theme was composed solely by Zelda Sheldon, John Prior had, in fact, jointly composed it with her.

Justice Wilcox returned a resounding verdict in favour of John Prior, and awarded extensive damages and costs be paid. Legal estimates have the proceedings and judgement costing in excess of two hundred thousand dollars, although the judgement amount

has not been revealed to Connections.

The court heard how John Prior co-wrote the theme music with Zelda Sheldon, who claimed she wrote the work herself. She had come up against a creative block with her initial attempts to compose the music, and had asked John at short notice to assist. He then spent part of the next four days refining what is now the very identifiable show theme.

John Prior was paid a basic fee for his work, and then denied a fair share of royalties, which amassed at a steady rate in the years since. The music was registered with APRA
(continued on page 70)

Your Rights-

- You WRITE a song or part of it? Register with APRA (www.apra.com.au)
- You want to RECORD someone else's song? Get a license from AMCOS (www.apra.com.au)
- You want to PLAY someone else's song? Just do it, the venue pays APRA a license fee. Mobile DJ's MUST pay the fee too.

Happy clappy days as Churches go hi-tech



US churches are now opting for Broadway calibre stage lighting to enhance the emotive power of their services- and Australia is set to follow.

"They get the audio going strong first" said Greg Keen from Sydney outlet Lots Of Watts. The firm just outfitted the Shire Christian Centre with a PA worth over A\$100,000. Also in Sydney, Hills Christian Life Centre have massive expansion plans, while Oxford Falls Christian Life centre has a TV studio.

Churches large and small are turning to non-traditional means for the presentation of services, religious concerts and member productions, and the use of special lighting effects to support these events is growing, according to Vari-Lite International.

"One reason people choose a specific place of worship is because of the emotional feeling they get from the worship services," they say.

Vari-Lite's new VL2400 Series wash luminaires and the VL2201 spot luminaire (above) are now targeted for direct sale into Churches.





With all your Meyer Sound gear out there working for you, you'll need to find new ways to use that empty warehouse.

You'll think of something.

In the best of all worlds, your warehouse stays empty, with every piece of gear out there working. And with that in mind, it's time to take a fresh look at Meyer Sound. Our loudspeaker systems provide the finest audio quality, are simple to set up and exceptionally reliable – designed to be in demand.

We've never approached the professional sound reinforcement market like others do. We've never been followers. That's why all Meyer Sound loudspeakers are self-powered. Every system component is a self-contained building block. Amplifier racks are eliminated, so systems are easier to configure, set up and transport. Wiring is a piece of cake. Set-up and tear-down are faster, needing smaller crews and less truck space. And our new QuickFly™ rigging system makes array assembly and flying a breeze. Just add signal and mix well.

So why not check out Meyer's self-powered touring systems and talk to us about your needs? Then start working on your backswing.



Meyer Sound

**www.meyersound.com.au
sales@meyersound.com.au**

**Toll Free
1800 4 MEYER (Australia)
0800 3 MEYER (New Zealand)**

Meyer Sound Australia Pty Ltd
PO Box 595 Albion Qld 4010, Ph 07 3252-4493, Fax 07 3319-6016

CONNECTIONS

ISBN: 1320-5595

CONNECTIONS is published monthly - except January - by Connections Publishing Pty Ltd
 Australian Company number 058 443 182
 ABN 66 058 443 182

Mail: PO BOX 439, EPPING
 NSW 2121 AUSTRALIA.

Deliveries: 16 Willoughby street.

Web: www.conpub.com.au

Email: mail@conpub.com.au

Phone: +61 2 9876-3530

Fax: +61 2 9876-5715

Lazy Hours: 0900 - 1700 Sydney.
 After hours try any of the mobile numbers below, email, or fax.

Advertising:

Caroline Grafton, (sales director)
 caroline@conpub.com.au,
 call toll free 1-800-635-514
 or +61 2 9876-3530.
 Mobile 0418 401-503

Subscriptions: call toll free
 1-800-635-514 or +61 2 9876-3530
 or email sarah@conpub.com.au

Bulk sales, dealer sales: toll free
 1-800-635-514 or +61 2 9876-3530
 or email sarah@conpub.com.au

Newsagent sales: NDD code CNC.

Publisher and editor: Julius Grafton
 julius@conpub.com.au
 mobile 0408 498-180

Technology editor: John Grimshaw
 john@conpub.com.au
 mobile 0408 833-394

Melbourne bureau: Mandy Jones
 mandaj@deakin.edu.au
 mobile 0414 537-847

Contributors: Worldwide.

Write for us: We welcome your unsolicited material, however rough, and we don't mind spelling mistakes. If your stuff is exactly grammatically correct and gorgeously spelled, we reserve the right to introduce *small errors*, to maintain our track record....

Legals: Nothing herein to be reproduced or transmitted by any means without the express written approval of the publishers. All contents copyright of Connections Publishing Pty Ltd. All material thought to be correct at time of publication, but we accept no legal responsibility if it isn't. You can always take legal action against us, but in any case we always prefer to run a correction in the very next available issue if anything published herein is faulty in fact. We have made every reasonable effort to track original copyright holders.

Lawyers: Depends.

Why do you want to know?

Accountants: Partlett, Chave and Rowland, Sydney.

Printed in Sydney by: John and Garry and crew at Superfine

Reprographics: Omicron. 8th year.

IT consultant: Brendan (is the) King

Platform: Apple Mac G3, G4 (Page Maker 5) on a Win 2000 server.

Superb advertising production:
 Sharon Miceli, call +61 2 9981-2891
 (not while Young & Restless is on TV)
 or email smiceli@one.net.au

Direct from the Shootout at the LA Corral....

John Grimshaw chooses the best of the bunch, in our EXCLUSIVE report on how the very latest video and data projectors compare, side by side!

Anaheim USA: The universe starts at Infocomm 2000 for four days in June, where ICIA runs the extremely famous projector shootout. This year, 76 projectors were divided into eight categories and shown side by side

Amongst all of these comparisons were some expected "winners" as some as some unexpected surprises. Interestingly, Sony chose not to take part in the shoot out. Considering it has very good quality projectors in most of the categories, it was a notable absence.

A Sony representative indicated that they chose not to take part because they felt that there would not be enough difference between the projectors for the exercise to be worthwhile. Apparently it was a marketing decision.

This is a very interesting position to take considering many of the astute people who went to see the comparison left with a better idea of which projector would be best suited for various applications. With a staggering variety of projectors available and coming soon to the market this may not have been a particularly wise decision for Sony to make.

It is important to consider that these projectors relied heavily on the technicians that set them up. A bad colour balance by a careless technician can easily stain the reputation of what could have been a very good projector.

I chose to pick the best picture based on what was shown on the final day of the shootout to give the manufacturers the maximum amount of time to tweak their product. This "human factor" could be the reason why lesser models in a particular brand ended up with better pictures than better models by the same company.

Ultra Portables (under 8lbs)

I had two favourites in this category...

- The **Toshiba TLP-B2** is a 1024x768 native resolution, 1000 ANSI lumen LCD projector. It had a very good colour balance and contrast, and high-resolution graphics was distinct and clear - something that quite a few projectors in this range failed to achieve.

- Likewise the newly released **InFocus LP350** also had a very smooth and stable



InFocus LP350 - our pick of the new Ultra Portable projectors

picture when showing high-resolution graphics. The InFocus projector was not officially released when it was previewed at Infocomm. It is a 1024x768 native resolution, 1300 ANSI lumen projector - however its image source is DLP - not LCD. This has the result of giving it slightly better blacks than the Toshiba. The LP350 will be officially released in July.



Toshiba TLP-B2

The Toshiba retails at US\$6495 and the InFocus is US\$6999. Expect to pay double in A\$.

Portables A (less than 30lbs and less than 1500 lumens)

- Although it was hard to pick, the **Sanyo PLC-XU22N** was the projector I chose in this class. It is a LCD projector with a native resolution of 1024x768. Most projectors in this class failed when it came to projecting high-resolution images, most of them generating distortion jitters in the test patterns used. However, Sanyo's machine was

> Continued on page 36

Who is doing what?

Life after Olympics not so rosy

Super Dome leads list of worries as NSW Government considers return on investment from venues at Homebush Bay

Sydney's venue glut is set to intensify once Olympic and Paralympic events finish later this year. But a surprise review of the future of the Sydney Exhibition Centre has the entertainment industry worried that it will be closed to bolster the flagging fortunes of the Super Dome.

Located out at Homebush Bay, the Super Dome has failed to attract commercial events due to transport issues and lack of nearby amenities. The fear expressed by promoters is that the Government may close the Entertainment Centre, sell the site, and thus force events out to the Super Dome.

Connections has been told by several major promoters that they simply would not

take the risk on shows at Homebush Bay.

"The Happy Days debacle proved you just can't expect people attending a concert to take the train" said one, citing the fact that rail services to Homebush Bay are at best patchy, and also deliver punters some distance from the Super Dome. Happy Days opened almost an hour late as thousands of cars were gridlocked outside.

This magazine ran the ENTECH trade show at Homebush Bay in March, and experienced first hand the problems of a remote site - and the difficulties of trying to co-ordinate parking and transport.

Sydney Entertainment Centre has attracted wide industry support for its struggle to remain open, hopefully sanity will prevail.

By Julius Grafton



Sydney's **Laservision Macro-Media** recently won the International Award for World's Best Outdoor Show for their latest permanent attraction at South Korea's Everland Theme park, (above). *Congrats.*



Tie down the load, sport!

This just in from the driveway at ARX in Melbourne - an example of *what not to do!* A bit of snappy acceleration away from the lights, and WHAMMC - no back window. THE number plate has been changed to protect the guilty.

~Vale~

Dick "The Fuse" MacGillycuddy

Richard Neville deCourcy MacGillycuddy passed away in Sydney recently, at a respectable age but still a little early. His funeral was attended by a good number of lighting and theatre industry persons.

Dick was well a respected theatre technician with a long history of working in various parts of the industry. He is fondly remembered, judging by the numerous humorous anecdotes of events he has worked on.

Once, Dick was working at the old Capitol Theatre as a followspot for pianist Victor Borg. As he was also working for the ABC at the same time, Dick was quite tired when he came to work on the show. Dick thought that working dome (*followspot*) for a pianist that does not move was the ideal opportunity to close his eyes for a bit. So, he locked off the dome, and proceeded to lightly lean on it to make sure he could get control of it quickly should he need to. Dick fell asleep.

Gradually, the dome started to move across the stage to OP, so Victor - rather than lose his light - started to move his stool and then the whole piano to follow the slowly moving light. By the time that Dick woke up, Victor and the piano were almost off the stage. The audience loved every second of the slow drama.

At the end of the show, the call went out for "that follow spot operator" to come to Mr Borg's dressing room immediately after the show. Victor tore strips off poor Dick, giving him a tirade about concentrating on the job etc - and then told him to do exactly the same thing for the next night's show.

PRESENTECH MOVES BACK HOME

Connections announces a series of changes

Our co-publication PRESENTECH has returned to where it came from, namely these pages. It couldn't quite stand alone out there in the cold wilds of magazine publishing. We gave it one brave year and a pile of cash, and we are enriched with some magnificent knowledge, and a much better understanding the audio visual constituency.

Because of this we have restructured the company to better reflect that we no longer publish two magazines. It meant that our long serving and loyal deputy, Nicole Morris, has departed for the brighter lights of downtown Sydney, where she is a new star at an events management company. Go girrrl!

After almost eight years non stop, we - the partners - have taken stock and made the decision to stay in this industry. We explored selling out, but instead have decided to look after ourselves better.

Step one is for Caroline to take long break from next month, ahead of the launch of ENTECH 2002, this September. The show has grown to the extent that running it is a fulltime job.

This necessitates some additional internal changes, with Julius Grafton moving out of the editorial chair to act as full time publisher for the time being.

John Grimshaw becomes acting editor. He foolishly looks forward to occupying the hot seat, and has unlimited access to trauma counselling.

- Caroline Fitzmaurice
and Julius Grafton

Who is doing what?

Mackie Introduces new Compact Mixer

The 1642-VLZ PRO is the first, completely new, high-end professional compact mixer offered by Mackie in over 4 years.

It features Mackie's new, precision-engineered XDR (Extended Dynamic Range) premium mic pre-amps. The new XDR mic pre-amps offer an exceptional 60dB-gain range with ultra-low noise and the highest headroom in its class.

The new 1642-VLZ PRO joins the current Compact VLZ PRO product line and is being marketed to Mackie's core product market base which includes professional recording engineers, home and project studios, secondary mix, broadcast and post production applications, and theatre and multimedia applications.

Price including GST A\$2595.

• Australian Audio Supplies, FreeCall 1800 50 20 15.



New AV trends emerge at INFOCOMM

John Grimshaw reports on the very latest in PLASMA, control, and projection

Anaheim Convention Centre, California: Infocomm 2000 was a stunning trade show, with all of the contributing manufacturers providing a non-stop visual feast of technology. Infocomm showcases the cutting edge of display devices, projection, presentation, media distribution, control systems and many other associated technologies together in one room (Actually it was three *very big* rooms).

Judging by the millions of dollars committed by these companies in the high quality stands at the show, presentation technology is a very healthy industry and it is growing.

Video/data projection is the main drawcard for the trade show, and some of the trends at the show indicate that DLP looks to be the new projection technology of choice by most manufacturers. Some of the most impressive projection technologies were on display, and it was easy to see that traditional cinema film projector's days are numbered. In this issue, you will find Connections' choice of the best projectors that participated in the shootout held at the show.

Another technology that is now beginning to make steps out of the "too expensive" basket is plasma displays. While they still have a long way to go in this respect, the volume of sales, range of options and development of the technology all suggest that one day in the not-to-distant future, we will be choosing plasma over CRTs for computers and the home. After Infocomm, it

would seem that Pioneer, NEC and Fujitsu are shaping up to be the big players in this arena. It will be interesting to watch them and others manoeuvre for the number one spot in the years to come.

Control systems were also fighting for attention at the show. Crestron Electronics chose the opening day of Infocomm to introduce a new control system technology — the Crestron Isys (advanced touchpanel control system). The Isys system uses the new Distributed Network Architecture

(DNA) to make each of the new touchpanels have all the information and intelligence required to become an entire control system.

Crestron's main competitor — Panja (formerly AMX) also had a strong presence in the show, displaying and promoting their technology. Often it seemed that everywhere you turned, there was someone in an iridescent green "Panja" shirt. And of course, there were gadgets — everywhere.

Read on!

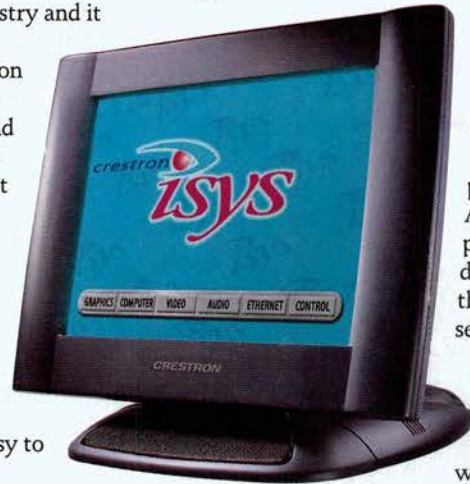

GEAR TO MOVE?

IF YOU'VE GOT GEAR TO MOVE,
CALL STAGE & SCREEN ON (02) 9383-4544

STAGE & SCREEN
TRAVEL & FREIGHT SERVICES PTY LTD

Pioneer

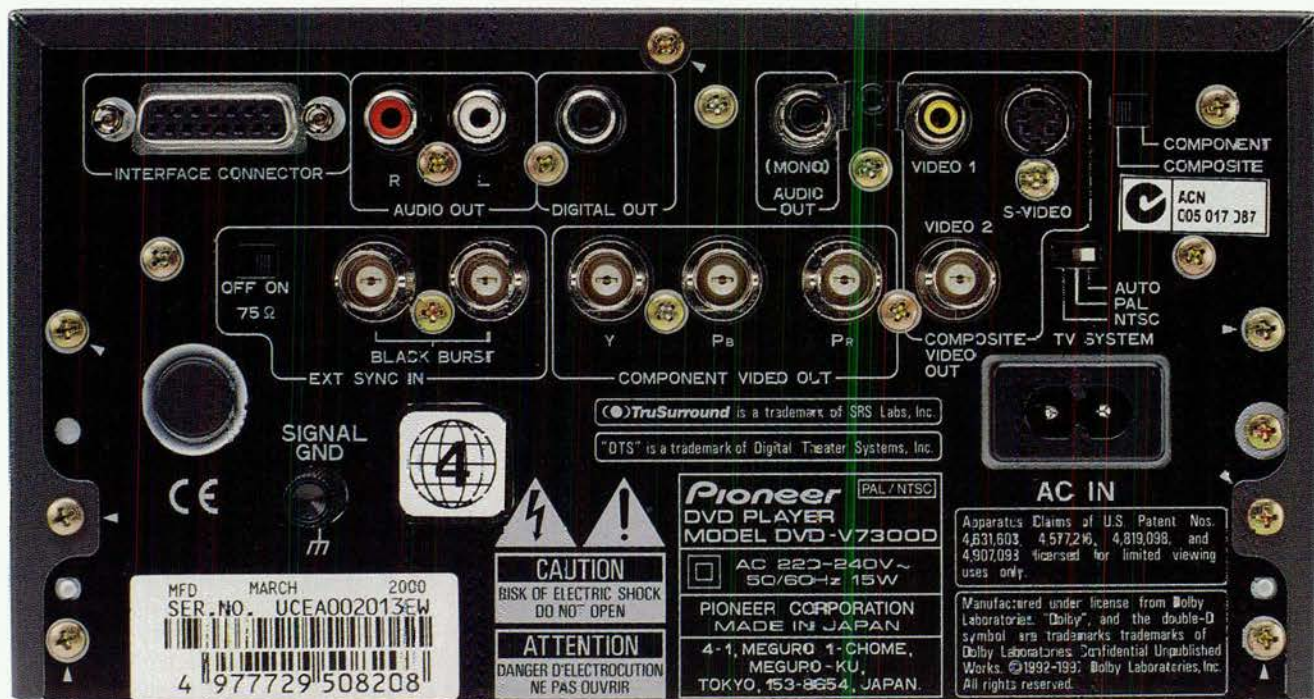

DVD MULTIMEDIA is EASY with the right CONNECTIONS

Pioneer is a world leader in the development, creation and application of DVD technology in all its forms



The first ever DVD-R Writer

especially Multimedia. Only Pioneer offers you the ability to write DVD-Video and DVD-ROM on the world's first ever DVD-R Writer, combining up to 4.7GB of data, vision and audio on a single disc in around an hour. Only Pioneer offers you a 720 disc modular DVD-ROM jukebox with multiple drive options including CD-R and



Hi-Res 50" 4:3 plasma display

DVC-R for a maximum 3.3TB of data. And only Pioneer offers you hi-resolution plasma display panels in either 4:3 or 16:9 aspect ratios, and a purpose built professional DVD-Video player featuring heavy duty drive mechanism, RS232C control, mouse and keyboard interface as well as a video blackboard. For further information connect with Pioneer and



720 Disc DVD-ROM jukebox



Industrial DVD-Video player

see just how easy DVD Multimedia can be. Freecall 1300 364 765 or explore Pioneer Multimedia now at www.pioneeraus.com.au.



Dr G's Gadgets

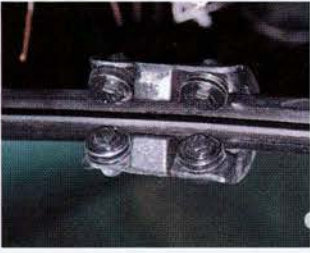

Barrel Runner

Want to use a standard 48mm OD pipe like a curtain track? Well, get a hold of this device. Called a "beam trolley", it was recently installed by Salken Engineering for the Ensemble production of "Intimate Exchanges" in North Sydney.

It is being used on a large section of curved pipe to roll some very heavy set pieces on and off stage. According to Bomac Engineering (the manufacturer), these devices were also used in the filming of The Matrix - to enable the cast to jump from building to building.

Bomac make about forty to fifty different varieties of trolleys for numerous different applications.

The trolley used by Ensemble Productions has a Safe Working Load of 100kg. The smooth running device has nylon wheels for low noise and will happily cope with curved and straight sections of pipe. It has an opening of around 15mm at the top to pass pipe supports.

Bomac Engineering
+61 3 9794 5715
www.bomac.com.au

Cat No: C06-40-A-100 (for 48mm OD pipe) SWL100kg - \$94.30 ex-tax

Cat No: C06-300-S-BH-SGR2 (for 60mm OD pipe) SWL300kg - \$121.30 ex-tax

MiniCity from Studio Due

New weatherproof CMY colour changer also A-O-K for indoor use

MiniCity is a CYM flood projector not only designed to colour buildings but equally at home transforming mundane interiors. It's a valuable tool for the corporate and special event market, because endless shades and colour saturations are accessible - and a simple CYM (*cyan, yellow and magenta, which together mix into millions of colours*) colourchanger with dichroic filters allows gradual colouring of the beam. Colour crossfades can be programmed at four different speeds or in real time.

The MiniCity uses a Philips Mastercolour CDM-T 150W lamp which has a very long lamp life of 6000 hours.

The Mastercolour lamp is manufactured with a UV-block technique which minimises ultra-violet rays thus making the lamp one of the safest for indoor lighting.



Wind, rain and dust pose no problem as the MiniCity has a high IP55 rating which guarantees perfect functioning.

The MiniCity has its own pre-stored programmes so it can run without DMX control. They can work singularly or synchronised with other fixtures.

• Around A\$3499.00 (incl lamp)

Contact Show Technology, +61 2 9898-1666.

NEW MIXER FOR HEADPHONE DOG

Mark Barry from BS Sound was happy with a 16 channel mixer. A simple man?

"For nearly 20 years I was happy with the challenge of doing sound for a 12 piece latin band with a 16 channel system. I would use a number of Y-leads to combine 2 mic's into 1 channel for brass and congas (and sometimes backing vocals)- bringing a 20 input stage set-up down to 15 inputs for my Yamaha 916".

"For me it is essential that I have the delay return into a channel (channel 16 but this is another story), and I had the reverb returns, CD & Cassette go through a home made sub-mixer to join the main mix via the aux inputs!"

"Anyway one day a Walk-In mixer just looked at me and said 'You're kidding! It



made me reassess my position as a supplier."

"So I bit the bullet. After much research I decided the A&H GL series is superior to the equivalents". Mark bought a 32 ch. GL 3300.

Now Conchita the headphone dog is barking happy! Call BS on: +61 3 9531-1403

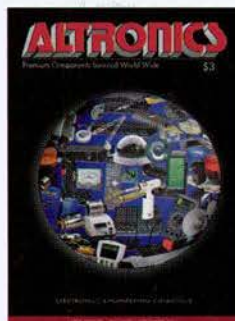

Altronics 2001 Catalogue is out in July. It has been produced entirely in-house by their own staff and is the result of over 1000 hours work. They have added many new audio/PA related products to the range. Including new UHF radio receivers, new 120V and 8r amplifiers, a new am/fm tuner and an extensive range of security/CCD equipment to name a few. The catalogue is online at www.altronics.com.au and they are offering a free copy on request if you email catalogue@altronics.com.au or phone or them 1800-670-072.

Learn to Mix with the

best

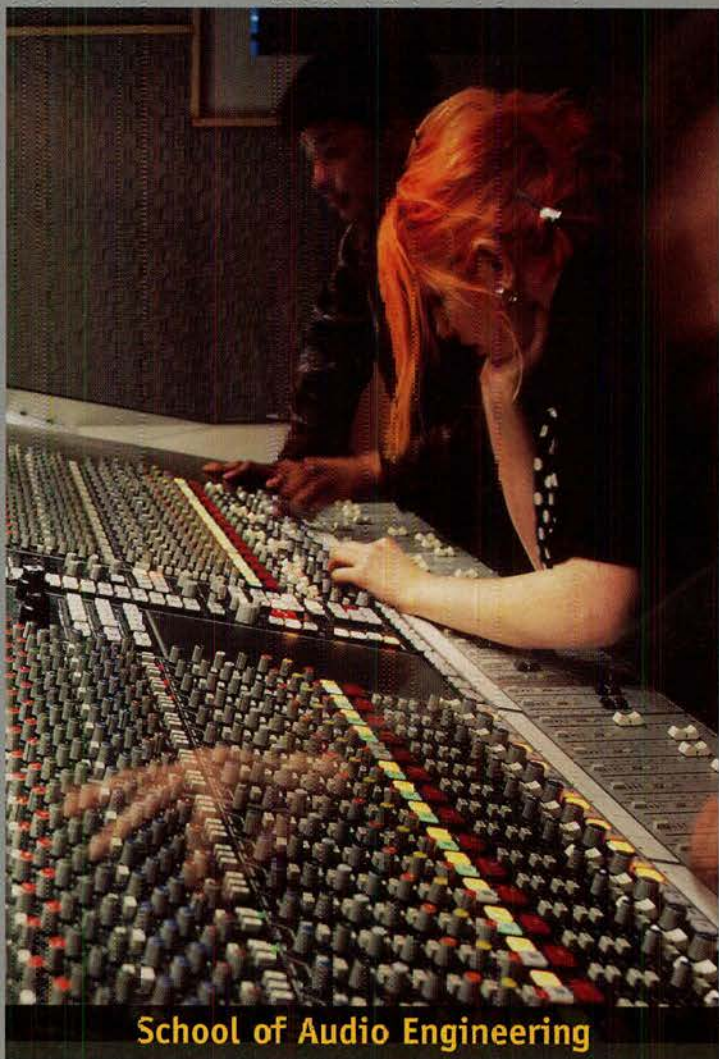

School of Audio Engineering



For more information and a free colour catalogue call any of these centres of educational excellence:

SYDNEY	55-57 WENTWORTH AVENUE, SURRY HILLS, NSW 2010, AUSTRALIA	PHONE: 02-9211 3711
MELBOURNE	2ND FLOOR, 14-16 FITZROY STREET, ST KILDA, VIC 3182, AUSTRALIA	PHONE: 03-9534 4403
PERTH	3-5 BENNETT STREET, EAST PERTH, WA 6004, AUSTRALIA	PHONE: 08-9325 4533
ADELAIDE	LEVEL 2, 282 GOUGER STREET, PO BOX 10411 GOUGER ST., ADELAIDE, SA 5000	PHONE: 08-8410 6599
BRISBANE	22 MAYNEVIEW STREET, MILTON, BRISBANE, QLD 4064, AUSTRALIA	PHONE: 07-3367 0143
HOBART	40 GEORGE STREET, NORTH HOBART, TAS 7000, AUSTRALIA	PHONE: 03 6231 5446
AUCKLAND	18 HEATHER STREET, PARNELL, AUCKLAND, NEW ZEALAND	PHONE: +649-373 4712

recognised practical audio education

individual studio time

the best studio equipment

industry guest lectures

active graduate placement

limited enrolments

the only international audio school

the largest and first audio school

small theory classes

full university degree BA

industry recognised qualification

established 1976

30 colleges all over the planet

active student exchange program

Australian government approved in all states.

*ONLY the SAE programs guarantee you
50% credits to the degree*

Certificate - Diploma - Degree

* Australia exclusive educational association with
SOUTHERN CROSS UNIVERSITY - LISMORE

* International exclusive educational association with
MIDDLESEX UNIVERSITY - LONDON

* In cooperation in sound engineering with

WALT DISNEY Entertainment[®]

Steinberg
Training Center

www.sae.edu

Who is doing what?

Installation Tools

Audio Telex have released a number of new 'Installation Tools', including two digital message recorders, a 100 volt speaker line to line level converter, a new SPL meter and the very clever "Load Master".

The Load Master is simply connected to any 100 volt line speaker run (from 30 to 500 watts) and displays the load is user friendly watts. Now that's handy !! +61 2 9647-1411

NEW ZEALAND'S LARGEST CASINO BULLET PROOF THEIR GAMING FLOOR WITH LSC LIGHTING CONTROL TECHNOLOGY

Auckland's Skycity Casino recently invested one million dollars in refurbishing the lighting of its gaming floor.

DMX equipment supplied by LSC Distributor, Grouse Lighting in New Zealand consists of forty-nine Isoport 1's and six Isopowers through a 10 way Multisplit. The equipment was installed by Kenderdine Electrical



in Auckland New Zealand and specified by Vision Design in Sydney.

Sky City Casino attracts more than one million visitors each year. At over 1000 feet high, its tower is taller than the Eiffel Tower in Paris and Sydney's AMP Tower.

• LSC: +61 3 9561 5255

Often Copied - Never Equalled!

Neutrik Professional Connector Systems, Patchbays and Test Equipment

The only choice when the pressure is on and performance is what really counts!



NEUTRIK
CONNECTING THE WORLD

Illustrated Cable & Connector Sourcebook - Out Now!

Amber Technology Pty. Limited ACN 003 234 137 www.ambertech.com.au



Sydney	Unit B, 5 Skyline Place, Frenchs Forest NSW 2086	Tel: (02) 9975-1211	Fax: (02) 9975-1368
Melbourne	Level 6, 10 Queens Road, Melbourne VIC 3004	Tel: (03) 9867-7111	Fax: (03) 9867-8277
Brisbane	220 Boundary Street, Spring Hill QLD 4000	Tel: (07) 3831-8444	Fax: (07) 3831-8455
Perth	Fairlight On Air Systems	Tel: (08) 9479-1711	Fax: (08) 9479-1713
Adelaide	Toll Free Customer Service Tel 1800 25 1367	email: sales@amber.aust.com	

SYDNEY'S FIVE RINGED CIRCUS MOVES INTO OVERDRIVE

There are confidentiality clauses in every supply contract for the Olympic Games, but Connections is hot on the case to bring you advance coverage of who is doing what and what with. Meanwhile, Brisbane company **Creative Lighting's** new 'Control Freak' series 'Showpro 2000' will be controlling all the major venue signage. (See www.creativelight.com)

Oceania Australia adds Midas 3000 consoles + studio

Oceania Audio in Australia now have three Midas Heritage 3000 consoles available for FOH and Monitors. They have established themselves as the largest supplier of Turbosound Flashlight and Floodlight Cabinets in Australia.

They have also installed a small studio for SFX and Post production work. This includes a V5.0 ProTools rig which come with 888 and ADAT I/O, 7 x SampleCell TDM cards, Logic Audio Platinum software and CDR facilities.

• Call +61 3 9362-0499

The leaders in light.

Technology and creativity in lighting.

SGM, an unbeatable group that for 20 years has been inventing and producing the most updated lighting products that professionals and lighting designers from all over the world request. What more is there to ask once you have creativity and technology all in one?

Don't be satisfied with just "A Show" make "The Show" with SGM's product range: *Moving heads, Scanners, Followspots, Colourchangers, Lighting consoles, Dimmers, Strobe lights, Smoke Machines and Gobos.*

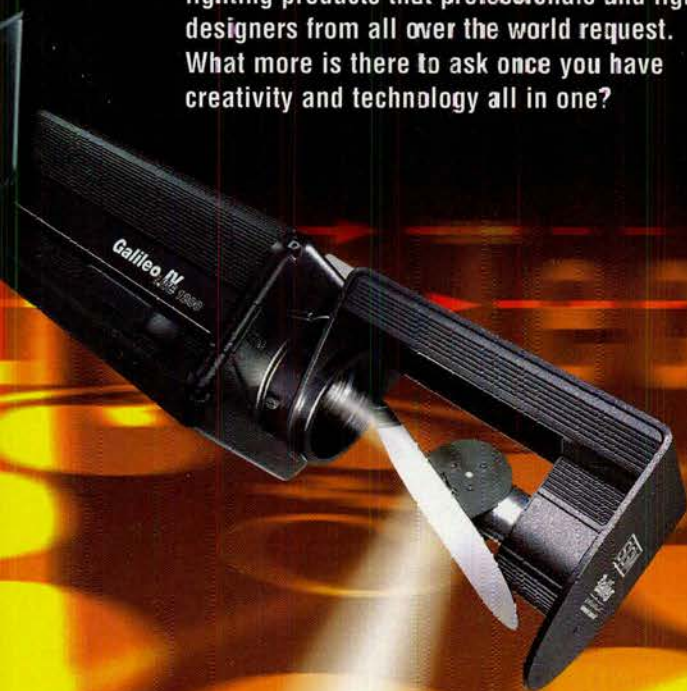

SGM Elettronica srl • Via Pio La Torre, 1 • 61010 Tavullia (PS), Italy
Tel. +39 0721 476477 • Fax +39 0721 476170 • <http://www.sgm.it> • E-mail: info@sgm.it
Jansen Limited • 4 Huntly Ave, Grafton • Auckland • New Zealand
Tel. +64 9 3773663 • Fax +64 9 3075884 • E-mail: mail@jansen.co.nz
Universal Lighting & Audio Pty Ltd • Freephone Australia Wide 1 800 648 111
QLD Tel. +61 7 5532 9922 • VIC Tel. +61 3 9310 4499 • www.ula.com.au • E-mail: ula@ula.com.au

From INFOCOMM

Extron Releases A Product - or two

Not content with having a huge range of equipment, Extron released more than 70 new products for Infocomm 2000.

Extron is growing into one of the major manufacturers of video switching and scaling equipment for any format, and up the broadcast standard specifications.

Some of their highlights include the SGS408 seamless graphics switcher. It has eight inputs, each of which is scaled to the desired output resolution. The output resolution can be anything from 560x384 to 1600x1200. The switcher has a true preview buss - something that is often taken for granted on high-end video switchers. The RCP1000 is a full-featured remote control panel for the SGS408.

To increase the functionality of this switcher, the ECP1000 event control panel controls up to three SGS408 switchers for direct control of cuts and transitions over three display screens. This device will allow wipes and transitions over all three screens consecutively or simultaneously.

Extron have also released five new video cables and a 15-pin HD monitor cable with audio, which has a 90 degree 15-pin HD plug on one end.



Pioneer Plasma the floor at Infocomm

It aint no dancefloor! It could be, but whose got the millions needed?

One of the more stunning displays at Infocomm 2000 was the Pioneer Electronics stand.

In a bid to show just how committed they are to the production of their 50" plasma display, they used 135 of them mounted on a special frame and then covered in thick perspex. The resulting effect was an amazing (and often disorientating) one that would be the buzz of any dance party - if you could afford the millions of dollars it would cost to put it down.

Each of the screens was fed a discrete video signal from the four Vector image processors, which were used to create numerous images that slide across the display and under your feet. The whole floor was square shaped with 15.2m sides, and required 36 fans to keep it

under the maximum running temperature of 40.5 degrees (C).

The unit used was the PDP-502MX, which is the model that is about to enjoy increased production rates when a second production line starts running in Japan shortly. While drinks and food were strictly kept off the stand, the display begs the question of just what do you do with 135 "slightly used" Plasma screens?

Also on display at Infocomm was Pioneer's new CD/DVD archival stack device. Capable of holding up to 720 discs, the DRM-7000 can house your choice of up to 16 CD/DVD/CDR/DVDR drives. Designed with a thin profile to allow multiple units to be placed side by side, the maximum storage capacity is a staggering 3384 GB. **-John Grimshaw**

Sony debut small projectors

After the release of the highly successful VPL-CS1, Sony has updated the VPL-CS1 as VPL-CS2 as well as adding a VPL-CS10, VPL-CX1 and VPL-CX10 to the range. The CS projectors are both SXGA resolution, and the CX are XGA resolutions.

The lightweight CS2/CX1 models have a light output of 600 and 550 lumens respectively and weigh in at 2.9kg.

Slightly up-market, the CS10/CX10 - have three 0.9-inch LCD panels and can be used for ceiling or floor mount and rear projection. The VPL-CX10 boasts 1200 ANSI lumens and VPL-CS10 gives 1000 ANSI Lumens.

Save Time Visuals

**SALES • RENTAL • HIRE
SERVICE • INSTALLATION**

**Audio Visual
Multimedia &
Presentation Specialists**

(03) 9888 2111

www.savetimevisuals.com.au

Save Time Visuals
63 Wadham Parade
Mount Waverley
VIC 3149
Facsimile (03) 9888 2904
Email savetime@wire.net.au

road tested



Introducing the CA18 power amplifier from Crest Audio

Crest products are born for life on the road. Back in 1979, we began making amplifiers specifically designed for the demands of touring concert sound. Today, Crest amplifiers and mixing consoles are the first choice of leading concert sound rental companies. Now, Crest adds the all-new, 5000-watt* CA18 to its acclaimed CA Series.

This established line of affordable amplifiers delivers superb, undistorted sound consistently - even into 2 ohm loads - thanks to Crest's legendary "overbuilt" power supply.

CA's keep their cool with the industry's most effective thermal management system, and provide fail-safe operation with Crest's unique TourClass® protection circuits. Every amplifier is subjected to the most rigorous quality control and testing procedures.

To top it all off, all CA amplifiers come with a five year warranty at no extra charge.

Call for your copy of the complete CA story.

Crest Amplifiers: the road tested choice of touring professionals worldwide.

*Power at: 4 ohm s bridged, 1kHz, 0.01% THD+N.

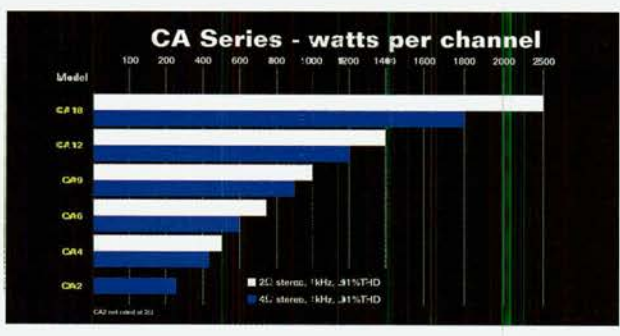

EXCLUSIVE AUSTRALIAN DISTRIBUTOR:
PRODUCTION AUDIO SERVICES PTY LTD
 6-E Elizabeth St., Richmond, VIC 3121 Ph: (03) 9415 1585 Fax: (03) 9415 1595
 Website: www.productionaudio.com.au
 Crest Audio Website: www.crestaudio.com

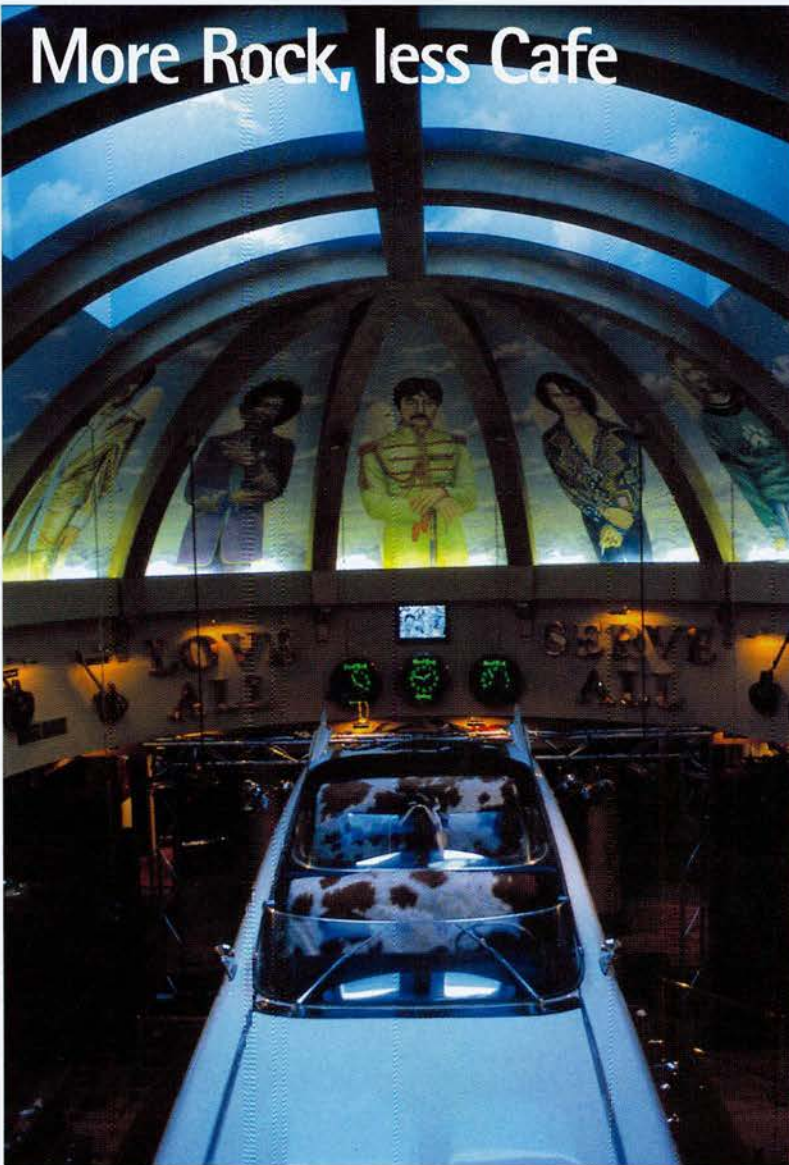

More Rock, less Cafe

Resurrection after the great fire sees Turbosound at home in Sydney's Hard Rock Cafe. Julius Grafton investigates.....

Sydney's Hard Rock Cafe is resurrected after a big fire - and with a new format - more rock, less cafe. The star studded opening night revived old rock excesses with a marquee in the closed off side street 'for you to do business in' said host Richard Wilkins. Business?

The place now has three things it didn't have before. Live bands play Wednesday, Friday and Saturday; you can buy a drink without eating; and a new Turbosound



installation.

It's the first Hard Rock on this planet to deviate from a standard JBL spec, and this was because Adam Clark and Andy Irvine from Melbourne installation firm **Centre Stage Australia** did some deft footwork. They convinced the client that their design, based on Turbosound TCS-30 contracting series loudspeaker systems. The little Turbosound boxes won the gig after an on-site demo, where they were A-B'ed against the specified model.

To give the place a consistent 115dB throughout the two levels and in all the nooks, corners and crannies, 30 boxes are arranged in seven zones. Four Turbosound Impact 110 bandpass subwoofers are discretely built into the room for extra bass.

The TCS-30 does deliver good low end response, however, due to the rear baffle design. When placed within 30mm of a wall, the two 5" speakers actually provide low frequencies down to 70Hz (at the minus 6dB point). The cabinet is loaded with a 1" compression driver, and distributes 100 degrees wide and 60 degrees vertically.

Centre Stage spec'ed a neat box for distribution duties. The way the system works, a little Spirit Folio mixer handles inputs from a Databeat hard disk music replay system - the primary background music source. There are also a CD and a DAT deck. The mixer feeds to an Ashly VCM-88 voltage control amplifier system, which has 8 zone outputs internally matrixed. This provides the 7 discrete zone outputs required. Where it is a neat box (at A\$2,395 list with gst) is that it has VCA control over the outputs - so a remote volume control (a 50k linear pot) can be run out to anywhere on a site, on simple twisted pair cable. Thus bar, room or the manager's office can turn up/down as required. Its final feature is best, it has limiters which you can preset on each channel, so nobody can blow anything that they don't want to.

The 7 zones are then fed from the VCM-88 into 2 x Ashly Protea 4.24GS Digital System II Equaliser/Processors (see picture, below).

The Protea is a digital system processor that offers 31 bands of EQ, compression/limiting, delay, high-pass/low-pass filters, and programmable memory and recall. They allowed Centre Stage to individually tune each zone, time align the signal, and provide limiting protection to the speakers - all in 4RU of rack space

The room is run on 9 Crown CE1000 and 2 Crown CT 410 amplifiers.

With a contract to install the system, Centre Stage turned to Sydney Turbosound dealers, **Innovative Lighting and Sound**. Jeremy Koche and Brendan Sadgrove did much of the work. They are now responsible for supplying band production for those 3 days of the week.

Turbosound will feature for band reinforcement too, with 4 x TQ440 SP self powered 3 way bi-amped boxes, 2 x TQ-425 SP front loaded dual 15 powered subs, and 6 x TCS-12m wedges - driven by 2x650 Pulse amplifiers. Rock on! •

MiniMAC



- Bars
- Restaurants
- Theme Parks
- Hotels
- Sports Arenas
- Discotheques
- Pubs
- Museums
- Arcades
- Dance Halls
- Cafes
- Funfairs
- Shopping Malls
- Ferries
- Car Dealerships
- Retail Outlets
- Fashion Shows
- Live Concerts
- Corporate Foyers
- Cruise Ships
- Theatres
- Health & Fitness Clubs
- Bingo Halls
- Churches
- Exhibitions
- Conferences
- Architecture
- Casinos

Where would you put yours?

... and runways

Martin
Professional Lighting
A U S T R A L I A

A division of Show Technology Australia Pty Ltd

13-15 Bridge Street • PO Box 480 • RYDALMERE NSW 2116 • Phone 61 2 9898 1111 • Fax 61 2 9898 1222
E-mail: Martin@showtech.com.au • Website: <http://www.showtech.com.au>

Who is doing what?

Melbourne JMC Academy

JMC Academy - Melbourne - is now open, and offering a Bachelor of Engineering Technology (Audio Engineering) and an Advanced Diploma in Music Business Management.

From 2001 all courses - including certificates, diplomas and bachelor degrees in Audio Engineering, Digital Animation and Television Production, Music Business Management and Music Performance - will be offered.

Renkus Heinz returns to Australia

After a decade of on and off representation in the region, major USA loudspeaker system and component manufacturer Renkus Heinz have announced that Horwood Australia have been appointed exclusive distributors in Australia.

The signing with Renkus Heinz follows the recent appointment of Horwood as the Australian distributors of Lectrosonics (LecNet) automatic mic mixers and ASPI Digital echo and noise cancellation systems for the audio visual and conferencing market.

Director of Sales for Horwood, John Musch believes the appointment as the Renkus Heinz distributor, along with such leading manufacturers at Lectrosonics and ASPI marks a change in direction and ideally places the Company as a supplier of premium brands and not just a supplier of peripheral products.

He added, "these products marry with others distributed by Horwood, including White Instruments, Atlas Sound, Furman Power Conditioning and Euromodule racks".

• Horwood Australia, +61 2 9585 1011.

The new self-powered 3-way Turbosound TQ-440SP establishes a superior benchmark for this class of speaker system.

Through the use of cone-type transducers up to 8kHz, the TQ-440SP excels with the spoken word, music playback and combinations of the two — by an extraordinary margin compared with conventional 2-way systems.

Physical time alignment of the HF and midrange drivers contributes to authoritative clarity and unsurpassed projection.

This audio superiority is enhanced by a highly sophisticated range of rigging hardware.

By eliminating the distractions of performance and installation compromises, the TQ-440SP allows you to focus on what really counts: presenting your audience with the best possible sound.

For multi-purpose venues and rental operators, the Turbosound TQ-440SP is peerless.

QLight™

TQ-440SP 3-way self-powered TQ-440 3-way bi-amped

**Visualise the invisible
Hear the light**

Turbosound
KNOW HOW

Turbosound QLight™ Series
Self-powered and bi-amped full-range and sub-woofer speaker systems for theatre, corporate and AV applications. Bi-amped version requires matching LMS-D6 controller.

Turbosound QLight™ Series is black. TurboBlue™ finish available to special order. Comprehensive model-specific literature and EASE data is available at our web site, or from your local Turbosound dealer.

Corporate Audio Services 188 Plenty Road Preston Victoria 3072 Australia
tel: +61 (03) 9474 1067 fax: +61 (03) 9474 1070 www.corporateaudio.com.au e-mail: mail@corporateaudio.com.au

STAFF APPOINTMENTS

New faces for the Jands Electronics' "Technical Resource Group", who supply the company's clients with product support, information and training.

• **Mark Hammer** has extensive experience in live production and contracting work, and is now providing assistance to



Jands' lighting customers.

• **Arsenio Fabay Jnr** joins the company as a product specialist for the dance music market. Arsenio has a strong back-



ground in this field.

• **Jeff Shoemsmith** was also recently appointed to work with Jeff Mackenzie in the areas of audio contracting and tour sound.



HDR24/96. MACKIE'S NEW 24 TRACK RECORDER. WORKS WITH ANY MIXER. NO EXTRA COMPUTER OR SOFTWARE NEEDED.

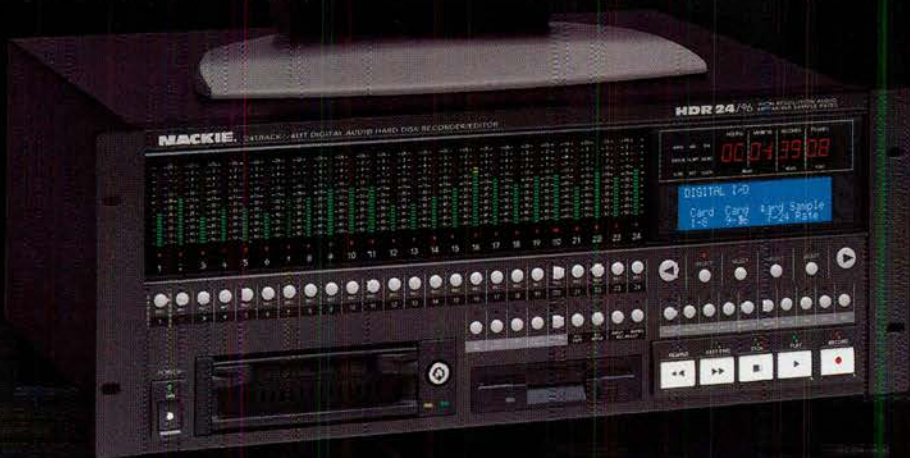

- | 24 Tracks_24-Bits
- | Built-in full-feature digital workstation editing
- | Affordable pull-out media
- | Built-in SVGA, mouse & keyboard ports
- | Built-in 100BaseT Ethernet
- | \$10,495 RRP (inc GST)

The Mackie HDR24/96 is the only recorder with built-in nondestructive graphic waveform editing. Just plug in a mouse, keyboard and SVGA monitor to view all recorder parameters on screen in real time. Enjoy complete editing control with unlimited levels of undo, drag-and-drop crossfades with 9 preset combinations, plus fade/crossfade editor. And look forward to DSP time compression/expansion, pitch shift and lots more!

The HDR24/96 is the only recorder that uses pull out Ultra-DMA hard drives, so affordable that you can keep one for each project - over 90 minutes of 24-track recording time costs less than a reel of 2-inch tape!

HDR24/96 editing features include 8 takes per track with nondestructive comping, nondestructive cut/copy/paste of tracks, regions or super regions, drag-and-drop fades and crossfades, 1x/2x/4x/8x/24x waveform views, true waveform: editing with pencil tool, bidirectional cursor scrub and unlimited locators and loops...with unlimited undos - but without requiring an external computer! Coming soon: DSP time compression/expansion, invert, pitch shift, normalise and much much more.

Use the HDR24/96 with any analog or digital mixer...or link it to our Digital 8•Bus desk.

- Built-in 27-gig Ultra-DMA disk plus front panel: bay for additional easily available, pull out drives
- Intuitive analog tape deck interface and monitoring
- Syncs to SMPTE, MIDI, Black Burst, PAL & NTSC without extra cards
- Unlimited HDR24/96 linking! Sync 48, 73, 96, 128 or more tracks sample accurately
- 96kHz recording via software & new PDI•96 I/O
- Uses Digital 8•Bus I/O cards - mix and match!
- 3.5-inch disk drive for software upgrades and tempc map importing
- Fast Ethernet port built-in
- Remotes available



FreeCall 1800 50 20 15 for our latest Studio Brochure and more info on the new Mackie HDR24/96.

Australian Audio

Distributed exclusively in Australia by:
AUSTRALIAN AUDIO SUPPLIES
Tel (02) 4388 4666 • sales@ausaudio.com.au

www.ausaudio.com.au

MACKIE
Digital Systems
www.mackie.com

DIGITAL MACKIES
AT OUR FACTORY IN
WOODINVILLE WA, USA



Photos by Peter Casamento - courtesy of Lightmove Pty Ltd

101 Collins Street: the mast is lit



Barry Webb & Associates, who specialise in lighting consultancy and electrical engineering, were recently commissioned by 101 Collins Street, Melbourne to relight the mast on top of the building.

The interesting factor about the job is that architectural lighting products were mixed with theatrical techniques to achieve a look that would normally only be seen in a theatrical environment.

Due to the environment, all products had to have a long life lamp. Several products considered had to be abandoned because they did not have a suitable lamp life, even some fittings with a high IP rating.

Over a period of time, many trials were undertaken and, eventually, a final image consisting of three elements was chosen: mast floodlighting, neon outline and neon spire features.

The two existing floodlighting systems were incapable of illuminating the entire mast structure and so the two 30 metre spires were not visible at night. It was decided to place four Studio Due CityColor floodlights, supplied by Lightmoves Pty Ltd, at the bottom of the mast to light its lower section. Cost of replacement lamps was a

major consideration and the CityColor uses a long life standard architectural lamp available from multiple suppliers.

"The CityColors were new to the market, a floodlight that offered full colour mixing was a deal," said Roger Farley, Project Engineer for Barry Webb. "They were appropriate for the case of the mast and they were priced competitively. They've performed well."

Also at the bottom are four Siemens 2xW Sports Compact floodlights which are mounted behind Showcraft Architectural colour changers. Each colour changer houses six motorised trays, five of which contain coloured glass and one of which is a blackout.

On the top deck, lighting the inside of the two spires, are four WE-EE 250W FLIC floodlights with scaled-down versions of the Showcraft colour changers mounted on the front of them.

To complete the composition and define the top of the mast, a glow of blue light is provided at the top of each of the mast spires. Neon technology from TS&L Neon in Melbourne is used for this where a specially designed structure has been developed to encase the neon and allow for ease of installation.

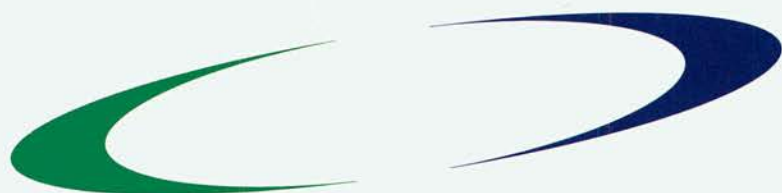

BIRKART FAIRS & EVENTS

Member of Birkart Globistics plc

60 offices worldwide



- Total World Tour Planning
- Airfreight & Air Charters
- Sound and Lighting Logistics
- 48' Concert Touring Vans
- Major Event Logistics
- Carnet Specialists
- Offices Worldwide



Let us perform for you!



BIRKART FAIRS & EVENTS PTY. LTD.

MELBOURNE:

28 Clarendon St. Southbank 3006 Vic. Australia
Ph: 03 9696 3607 Fax: 03 9696 5927
Email: phocking@iaccess.com.au

SYDNEY:

Level 2, Suite 4, Centrum Place 6-8 Crewe Place,
Rosebery 2018 NSW Australia
Ph: 02 9313 8694 Fax: 02 9313 8695
Email: chris@birkart.com.au

Check out our website
at www.birkartfairs.com

Proud to be associated with
our travel partners





Phase three of the project is yet to be completed - to provide a sense of continuity and attachment of the mast to the building, the plantroom structure immediately below the mast will be outlined with a continuous neon strip running along the top edge of the plantroom and down each corner of the structure. This lighting will help create the vision of a pedestal on which the floodlit mast structure will sit.

The control system had to have all the usual levels of control that is required for an Architectural control system, such as Photo Electric Cells to switch on and

off with the outside light levels. It also had to be integrated with the existing building management system. Additionally it had to control DMX 512 controlled light fixtures, and had to be able to be programmed and updated remotely.

"For example, the initial programming sessions were done in a building 4 city blocks from 101 Collins St" said Braham Ciddor of Lightmoves Pty Ltd.

"For the Midsumma Gay & Lesbian Festival the building owners requested that the colour be changed to pink. The new colour was programmed from the Lightmoves offices in Hawthorn. The Dyalite system that was

installed was the most cost effective of the limited number of commercially available systems that could do all that was required. The advantage of this system is that as the later stages go ahead additional products can be added in with a building block approach."

Some initial monitoring of the system during the early stages including checking switch-on times and sequence programming was done via a webcam that is actually mounted on the tower of 101 Collins.

"At <http://webcam.omni.net.au>, at the extremities of the camera's movement, we are able to see if the lights are on and what colour they are in," explained Braham Ciddor.

The electrical contractors for the project were Brolec.

New at Lots of Watts!

CLAY PAKY STAGE ZOOM 1200

- 3 Colour Mixing
- Electronic Focus and Zoom
- 8 Gobos 4 Prisms
- Electronic Iris
- Hot Restrike
- Colour Temp. Correction and UV, plus Colour Wheels
- Gradual Variable Frost



AVAILABLE FOR HIRE NOW

2 Bridge Street, Rydalmere NSW 2116
 Phcne +61 2 9638-0302, fax 9638-0331
sales@lotsofwatts.com.au
hire@lotsofwatts.com.au
www.lotsofwatts.citysearch.com.au

The company everyone else uses

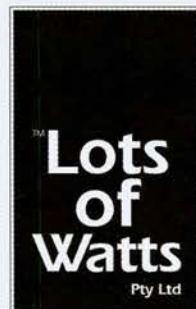

NEW Revolutionary Mobile Staging

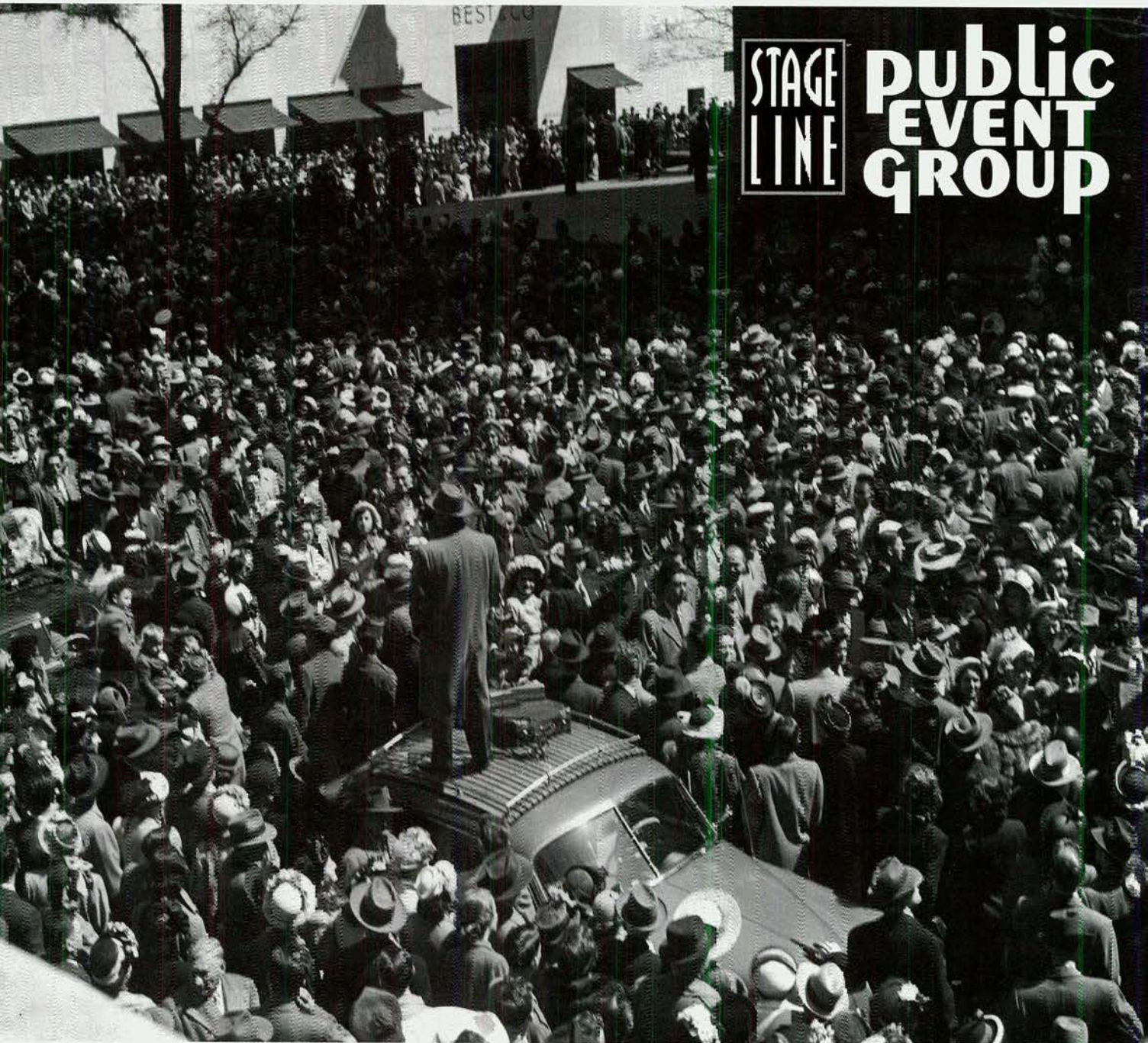

STAGE
LINE

public
EVENT
GROUP

www.publicevent.com.au

Concert Platform

Festival Stage

Online Specs

Online Quotes

Online Booking

Why is our new stage revolutionary?

It is more advanced than any other mobile stage and its cost makes it ideal for festivals and community events.

Major features are:

- Travel virtually anywhere
- Two operators one hour to set up
- Built in sound wings & PA support
- Rated to 150 kilometer p/h winds
- Goes up in any weather

- Rigging points for lighting truss
- Banner and signage options

See it on our Website or call about your staging needs anywhere in Australia.

public event group

tel 02 8585 5200

fax 02 8585 5252

group@publicevent.com

www.publicevent.com.au

What will you be using soon?



DALI is here...

Salvador would have had no great interest in the intricacies of light dimming control, but it is the name of a new tool for architectural lighting – one that avoids a complex and expensive DMX system.

DALI stands for Digital Addressable Lighting Interface.

It is designed to be a very robust, two-way digital control system for small to medium installations. With a low baud rate of 2400, this is not a system that is designed to use in the entertainment industry.

Under the standard developed for this protocol, up to 64 addresses can be present on one system. These addresses can be made up of any number/combination of control devices, specially designed ballasts and other interfaces, all of which can be placed anywhere on the control line.

One of the first product lines to be introduced with DALI capability is "Digidim" by Helvar. Their range includes electronic ballasts for 12V halogens, analogue voltage control interfaces, IR controls and sensors, and more.

• For more information, contact Gilbert Lodge Australia +61 2 9714 0400



FLASH RAM PORTABLE RECORDER

Marantz Professional has released the first in a new generation of portable field recorders based on Flash RAM hard disk recording media. With the combination of shock resistant recording, internal editing and electronic file transfer the Flash RAM media format ideally lends itself to field recording.

Using the Marantz PMD680 a location reporter can now take recordings and interviews on the fly, edit, add dialogue and compile a report then download the file to a laptop for transmission to HQ via a modem.

The new single channel recorder has been designed to make the Flash RAM format easy to use with large transport keys and selectable function buttons like speaker (on/off), record level (ALC/Limiter/Manual) and input (Mic/Telephone/Line) mounted on the

top face. The PC/MCIA Flash RAM cards achieve up to 80 minutes PCM recording (1.2G) and the FMD680 uses this capacity to provide workstation type facilities to cut, paste and edit a recording using the built-in speaker or headphones to monitor.

The choice of uncompressed linear 48kHz 16 bit PCM, or, compressed (with selectable bit rate) 48 kHz MPEG-I Layer II recordings are converted to an MS-DOS (Broadcast WAV) compatible file for editing either within the PMD680 or on a computer using a built-in Edit Date List which allows the recording to be arranged in any order without effecting the original recorded material. Editing on a computer can be via an MPEG audio editor, or a WAV editor for PCM recordings.

Price (incl GST) \$2,995.00

• Technical Audic Group +61 2 9810 5300

RANE UPGRADES POPULAR A/V ALIGNMENT DELAY

Rane has released an upgraded version of its popular AVA 22 audio/video alignment delay. The new model, the AVA 22d, features an updated DSP engine and new 24-bit converters which ensure the model is 3dB quieter than its predecessor.

The fully balanced two input two output delay provides a range of 0.0 to 9.5 NTSC or PAL/SECAM frames on each output with two non-volatile memories (no batteries required) for access to previously stored delay values. Remote recall screw terminals on the rear also accept external configuration

switches, permitting independent remote recall of the memories. The AVA 22d features XLR inputs and outputs and is CE certified. Housed in a single rack space, the unit can operate as two independent channels or as a stereo pair so users can edit both channels simultaneously using the link mode.

Front panel controls can be locked out using a recessed rear panel switch, and independent bypass relays provide a fail safe, hard-wired bypass in case of power loss.

Rane's AVA22d is distributed by Jands Electronics +61 2 9582 0909.



AN AUSTRALIAN LEGEND RENOWNED AROUND THE WORLD

"Australian Monitor amplifiers continue to give us reliable and clear sound quality throughout the 200+ days of the year for which they are in use. My senior technician calls your amplifiers "THE ULT MATE". They provide clean sound, are highly reliable and durable..."
Vern Medding, Calgary Stampede, Calgary, Canada

"We have around 70 Australian Monitor Amplifiers powering our very busy Martin Audio hire rig and other speaker systems. Our last batch we received the day before our Millennium NYE Celebrations, we unpacked the 34 amps and they all worked first go in -15 degree temperatures. That is why I always use Australian Monitor".
Sami Borgenstein, Radiant Sound, Finland

"Many many moons ago we were struck at first sight of the then new AM-series. When the audio performance turned out to be at the same level as the superb mechanical and electrical design, we choose AM as the new standard for the rental department. Some 12 years later that first amp is still happily performing just as well as the 30 others we have added since."
Roland Mattijsen, Audio Electronics Mattijsen/Netherlands

"When Basset Acoustics specified amplifiers for the Adelaide Festival Theatre's new million dollar LARES electro-acoustical enhancement system, the application demanded the highest purity and lowest noise possible. Australian Monitor was a natural choice"
John Matheson, Acoustical Consultant for the project (20+ channels of Australian Monitor), Australia

"We needed an amplifier with recognised brand power and total reliability. AM have an unbeatable reputation for reliability and performance and are a huge asset to our new hire rigs. We have a busy year ahead and can afford to take no chances, so we went with Australian Monitor".
Lindsay Gesling, Event Sound People, Canberra Australia



Australian Monitor

TOUGH, RELIABLE AND SONICALLY SUPERIOR

SITUATION CRITICAL

RELIABILITY IS EVERYTHING

DISTRIBUTED WORLDWIDE BY AUDIO TELEX COMMUNICATIONS

AUDIO TELEX
COMMUNICATIONS PTY LTD

www.audiotelex.com.au

NSW: Tel: (02) 9647 1411 Fax: (02) 9648 3698

VIC: Tel: (03) 9890 7477 Fax: (03) 9890 7977

QLD: Tel: (07) 3852 1312 Fax: (07) 3252 1237

WA: Tel: (08) 9228 4222 Fax: (08) 9228 4233

TAS: Tel: (03) 6228 6373 Fax: (03) 6278 1063

SA: Tel: (08) 8352 4444 Fax: (08) 8352 4488

NZ: Tel: (09) 415 9426 Fax: (09) 415 9864

Above all...



...it's a Sony

Sony Australia Limited A.C.N. 001 215 354 Head office: 33 Talavera Road, North Ryde NSW 2113 Web: www.sony.com.au
Sydney (02) 9887 6666 Melbourne (03) 9264 0200 Brisbane (07) 3334 4000 Perth (08) 9202 2555

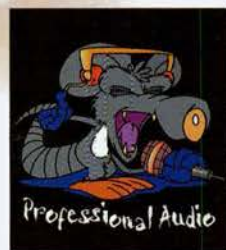

PANI single film scroller

Seen for the first time in Australia at ENTECH 2000, the FIGI single film scroller has been designed by French E/T/C Audiovisuel to fit all models of Pan: large format projectors. The scrollers offer new opportunities for existing Pani equipment common in theatre, opera, and on the rental scene.

Offering the same film positioning and scrolling accuracy of the other products in the Pigi range, the single scroller can be fitted either horizontally or vertically onto the projector and can be powered directly from the Pani accessory socket. Auxiliary outputs built into the scroller can drive Pani dimming shutters and other accessories.

Pani lenses attach to the front or the scroller can be fitted with the Pigi remote



focus universal lens mount.

The Pigi Single Scroller is available for sale or rental from The Electric Canvas who can provide film design and production of film scrolls

• Call +61 2 9437-9588

NEW Peavey AA CobraNet Devices

Peavey Architectural Acoustics have just released three new CobraNet Audio Bridges (CAB's). The CAB16i and CAB16o feature sixteen line level inputs and sixteen line level audio outputs respectively. Priced well below the competition, the new Peavey units also win on features, such as 24 bit converters and full metering.

The CAB's are perfect for many non-MediaMatrix applications as well, such as a digital multicore or basically, anywhere you need to send or route multiple channels of audio over CAT5 or fiber. Simply put a CAB16i at one end and a CAB16o at the other end and you have a sixteen channel multicore over 100 metres of CAT5 or (with media converters) 2km over fiber. Need a 32 channel multicore? Easy, just use two CAB's and a small hub at each end.

The third CAB, the CAB16d is a little different. This unit features sixteen digital in and out's (AES3 or S/PDIF). Other products in the range include the CAB8i (8 mic/line inputs, 8 CV inputs and outputs, 8 relays, RS485) and the CAB8o (same as the CAB8i but with line level outputs in lieu of the inputs). All CobraNet devices are now also compatible with Fast Ethernet Switches.

For more information contact your local Audio Telex office or e-mail us at mmsupport@audiotelx.com.au



iPRO is shipping

LSC Lighting Systems have just announced the release of their new iPRO dimmer, featuring 12 Amps per channel, 100% duty cycle rated operation, hard-firing of the dimmer channel and temperature dependent fan speed.

With the same core structure as the ePRO, the iPRO incorporates a unique mounting system to suit a number of differing installations. It allows the iPRO to be bolted to a solid wall, a 19" rack frame or in view of its sloped bottom end, the iPRO can rest on flat surfaces such as benches, floors or table tops.

Part of the iPRO's construction is a separate Installation Frame which allows for easy termination by an authorised electrician prior to construction.

Call LSC on : (613) 9561 5255

XM6150 ÷ 3U



= 6 x 150W



RMS @ 4 Ω



+ HPF



- XLR & Euro-block inputs
- Binding post outputs
- Amps bridgeable in pairs
- Precision rear attenuators
- Individual high pass filters (switchable)
 - Variable speed fans
- Individual amp status indicators
 - 18 Kilograms



PO Box 268, South Melbourne Vic 3205
Toll Free 1800 805 413 Fax: 03 9696 4579

Web Sites: www.yamaha.co.uk
www.yamaha.com/proaudio www.audio-technica.com

A.C.N. 004 257 527 Prices subject to change

Who is doing what?

MOVED

• **Brisbane Sound** has moved. They are now at 33 O'Connell Terrace, Bowen Hills, QLD 4006. Phone and fax numbers remain the same. Come and visit, they say!

• **Audio & Visual Innovations** likewise have moved, to 41 Brookes St, Bowen Hills, QLD 4006. Call Steve Grimes on +61 7 3252-4022, he says former partner Cam has left but it's amicable.

EXPANDING

• **BJ's Sound & Lighting** in Brisbane have purchased another 200 square metre building next door to keep up with the expanding market. Managing Director Brad Johnson told Connections they needed the space, so they grabbed it. +61 7 3854-1122.

CASSIDY'S DISPLAYS SOLD

• **Exhibition Hire Service** have purchased Cassidy's Displays in Brisbane and move on July 15 to bigger premises, at: 17 Lochlarney Street, Beenleigh, QLD 4207. Call +61 7 3382-6055. Everyone sounds happy about it!

DISTRIBUTION

• **Awave Productions** now represent Oram professional mixing and outboard, Trident, Cranesong, Oberheim, Big Briar Moogerfoogers (need one of 'em!), and Encore Electronics. Awave have a retail showroom with lots of music technology equipment on hand for demo's.

Lewis Chiodo has been around the industry a while now, and says his new business has a relaxed and quiet environment with real one-on-one service and support.

They are at:- Hawthorn, House, Suite 8, 795 Glenferrie road, Hawthorn 3122, Victoria. Call +61 3 9819-4603. Good luck Lewis!

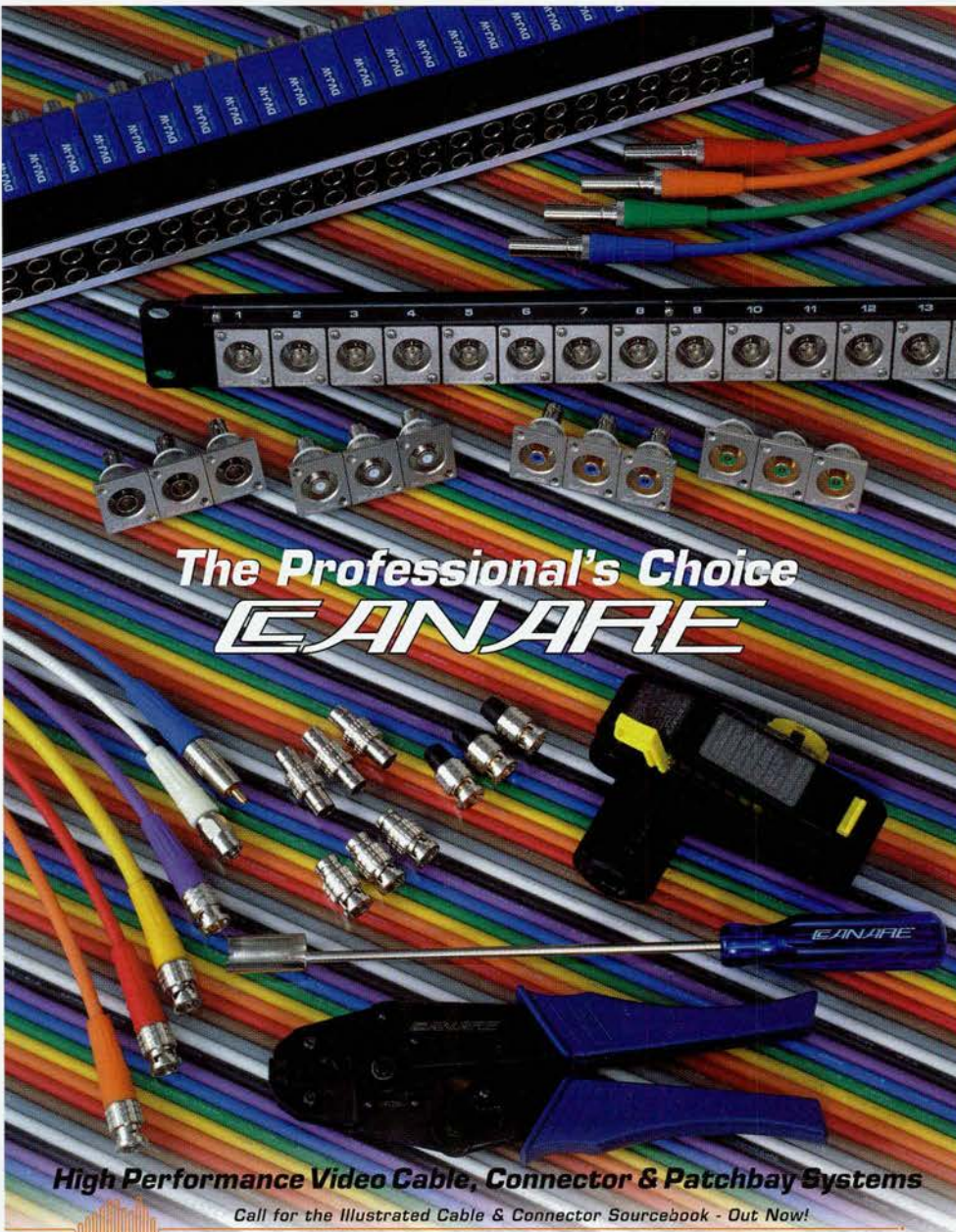

FREE INDUSTRY NIGHTS

Those popular Jands Industry Training/Info Networking Nights are scheduled as follows:

Sydney:

18th July: Signal processing
15th August: Amplifiers & Loudspeaker drivers

Melbourne:

8th August: Audio & Control via Ethernet

Brisbane:

25th July: Mixing 101
24th October: Signal Processing
Call Jands in advance on +61 2 9582-0909 to book and get venue details. The nights generally start at 7pm. Connections attended one in Sydney last month, it was packed out and - dare we say - fun. Free too!

MARTIN, A&H SALES

• **3200 Lighting Sydney** have added Martin audio Wavefront3 x 4 & 2 x WS2 subs to hire inventory.

• **Revesby RSL** have installed an 10 cabinet Martin Wavefront†8 system with QSC PLX amps

• **Jazzright productions Sydney** have taken delivery of an Allen& Heath GL4000-48 together with 8 of Martin's new concert wedge- the LE 12 J.

• **Liverpool Christian Life Centre** has installed a new 10-box Martin Audio Wavefront 2 system powered by QSC Audio PLX and a Allen& Heath GL4000-40, it was sold by Willy Route from WMR Electronics.



Amber Technology Pty. Limited ACN 003 231 187 www.ambertech.com.au
 Sydney Unit B, 5 Skyline Place, Frenchs Forest NSW 2086 Tel: (02) 9975-1211 Fax: (02) 9975-1368
 Melbourne Level 6, 10 Queens Road, Melbourne VIC 3004 Tel: (03) 9867-7111 Fax: (03) 9867-8277
 Brisbane 220 Boundary Street, Spring Hill QLD 4000 Tel: (07) 3831-8444 Fax: (07) 3831-8455
 Perth Fairlight On Air Systems Tel: (08) 9479-1711 Fax: (08) 9479-1713
 Adelaide Toll Free Customer Service Tel 1800 25 1367 email: sales@amber.aust.com



Give yourself
an unfair advantage.

Carry less gear. Use fewer trucks. Fly the rig faster.
Hire fewer helpers. Eliminate multiple arrivals.
Get better sound. Configure DSP settings to that night's
venue on the bus.* Eliminate guesswork. Make more profit.

EAW's KF700 Series: Give yourself an unfair advantage.

Meatloaf VH1 Storytellers Tour
Scorpio Sound

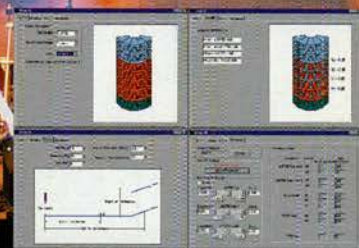

* Go to www.eaw.com to download the KF700 Series Wizard. The Wizard takes user-defined parameters and develops custom-configured, venue-specific DSP and AS3D™ array shading settings. It can even talk to your EAW MX8600 or XTA DP226. Cool, huh?

The Laws of Physics | The Art of Listening

EAW
EASTERN ACOUSTIC WORKS

One Main Street, Whitinsville, MA 01588 tel: 800 992 5013 / 508 234 6158 fax: 508 234 8251 web: www.eaw.com

EUROPE: EAW International Ltd, tel +44 1494 539090 fax: +44 1494 539091

AUSTRALIAN DISTRIBUTOR: Production Audio Services Pty Ltd, 6-8 Elizabeth Street, Richmond, VIC 3121, tel: (03) 9415 1585 fax: (03) 9415 1595 web: www.productionaudio.com.au

EAW is the worldwide technological and market leader in the design and manufacture of high-performance, professional loudspeaker systems.

Sound at the Soccer!



*ix by Geoff Atkins, Performance Photography

Crank up the volume

Phase 1 do the NSL Soccer Grand Final in Perth at Subiaco Oval

Most soccer enthusiasts held their breath when Wollongong snatched victory from Perth Glory. The sell-out crowd were speechless, while across the continent the denizens of Wollongong went slightly crazy with relief.

Phase 1 Audio were there, catering to 45,000 people with plenty of PA for entertainment and onfield sound. Because Perth weather is strangely predictable, rain planning was not required. The gear was rolled out at 6am for a 10am rehearsal. While a bit tight, the team led by Jon Caisley were right to go.

They laid out 20 EAW KF 750 cabinets - subhired from Keith Crammond of Audex - at each end of the stadium (reaching the higher stands) and 12 Martin W8C cabinets running along each side of the field. These were supplemented with 8 x RCF 18" folded Subwoofers.

"The system ran as four separate zones" Jon Caisley told Connections. "Both systems were excellent. To EQ the system we called it over radio whilst standing in the stadium. There was lots and

lots of walking".

Phase 1 Audio recently purchased 12 Martin W8C and QSC Amps from Steve Bray at TAG. "We're really happy with them" Jon commented. "They've got great mid range, and were using them for everything from corporate shows to the Soccer, including outdoor festivals. They're easy to handle and quick to set up". They are driven by 10 x QSC 3002 amps, and Phase 1 have 2 x Martin MX5 System Processors for the boxes.

The company started four years ago, Jon was doing lots of freelance and partner Sue was a Lighting Tech and AutoCAD operator. They do heaps of corporate work, like the dreaded Masters of Business greedfest, which drew 6,000 people to the Buswood Dome. Then there's various product launches for Nissan, Nokia, Motorola, Hyundai, and Ford, and live shows for Jebediah, Dave Graney, Dirty Three, Kenny Ball Jazz Band, Rebekah's Empire and others.

"Our gig was relatively simple", says Jon, "with walk in music, ground announcements and video rolls until 30 minutes before the game. Then we stepped up the program and volume. Helicopters dropped in with large flags, parachutists dropped in, purple and orange smoke canisters let go. There was lots of smoke, lots of build up".

> Please turn the page



The Lightweight Choice for Heavyweight Performance



The ART Series Speaker System, designed by RCF's Electro-Acoustic Laboratory, uses Advanced Resource Technology to guarantee you a new level in professional sound, portability and flexibility. The ART Series is simply the most innovative range of high performance loudspeaker equipment available, offering both active and passive systems for the professional in every audio environment.

Where else can you find 15" performance from 12" woofers?

All ART Series active speaker systems are designed with an exclusive 'TOESP' thermal and over-excursion speaker protection. So you can turn up the heat on your audience while keeping your amps cool, and all advanced active electronic components are packed into a rugged, slim-line polypropylene case weighing in at 20-22Kg - making it lightweight but heavy in power.

ART SERIES

Internal Power Amps

This is the area where most self-powered systems suffer the greatest area of compromise (where most shortcuts are taken). The RCF designers took no shortcuts to include a no-compromise serious power amp stage. Two high-tech, split-rail high-current amplifiers, supported by a high duty cycle power supply means a reliable power that will keep delivering long after most competitor's systems have shut down.

No Gimmicks Required

The system does not need protection through "gimmicky" devices such as sliding filters or load shedding, all of which alter the sound at high power or even worse, shut it off altogether.

Stay Cool When The Going Gets Hot

The amplifier heat sinks utilise air moving through the enclosure to dissipate heat, so it can therefore be slung at any angle without the risk of overheating. Most powered systems have thermal dissipation only on the rear, so will quickly overheat when on their back (foldback application).



State-of-the-art Design



ART 300A Input Panel

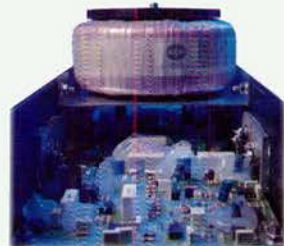

Built for Reliability

Concert Box Protection

The amplifier contains full system monitoring for speaker over-excursion, input limiting, thermal (*turns down, not off!*), and DC protection.

Independent Input Section

The input pre-amp stage is a separate isolated section with input/output and filter switches. Four preset EQ settings are available as well as mic/line level and volume control.

Accessories

The ART Series Loudspeaker Systems are packed full of great ideas to provide maximum flexibility, opening up a multitude of applications that would have needed twice the gear.

Accessories for the ART Series range from Protective Bags to a range of wall and truss-mount brackets. Other accessories include front metal grilles and a variety of installation hardware. The A1 accessory converts any ART speaker into a stable stage floor monitor. All accessories are thoughtfully designed to enhance the capabilities of the amazing ART Series.



A-7 Front Grille Accessory



Sound at the Soccer!

"From the mayhem we went into team announcements and the team anthem, the national anthem and away we went. Steve Armstrong - a local singer - belted out a few classic tunes. He thought it might be fun to go and sing in amongst the crowd. But I don't think he'll do it again. Aside from being drowned in beer and having his in ear monitors knocked out, he was having trouble actually escaping back on the field. But it looked like fun. I must make a point that Calinda Anderson from BBC Entertainment in Perth did a remarkable job of putting together the entertainment program".

The kick off saw Perth Glory play like they were possessed. They just hammered straight into it. The first goal saw fireworks in the goal mouth, tied in with an Angry Anderson track on (CD). The Glory Climbed to 3-0 before half time. "Soccer Australia requested that we not play any music or fireworks if Glory scored again!" said Jon. "They felt that the bias toward Glory was too strong."

"Half time saw more festivities, three songs and more dancing. everything was really up. The crowd were going berserk. Everybody expected a win. But the second half completely belonged to Wollongong. They picked up where Glory left off and kicked three goals also. Glory didn't get a look in. The equaliser was delivered about 1 minute before the final whistle and

already into injury time!"

A tie in a soccer final calls for a further 15 mins each way or who ever scores first. If there is no score it comes down to a penalty shoot out. There was no score, it went to a penalty shoot out.

"The stadium was totally intense. From being outrageously loud it felt as if somebody sucked all the energy out, you could have almost heard a pin drop".

And, Wollongong took the cup home with them.

Phase 1 used an Allen & Heath GL3000 console,
3 x BSS 966 Opal graphics,
2 x DBX 160S Compressors,
2 x Shure UA Radio Mics,
and
1 x Shure In Ear System

The EAW system ran on

8 x Crown 3600 amps
9 x Crown 2400 amps
with 2 x BSS Compact
Omnidrive speaker management
devices.

The crew were:

Dave Caisley
Dean Harris
Kade Ward
Andrew Newnham
Dean Daniels

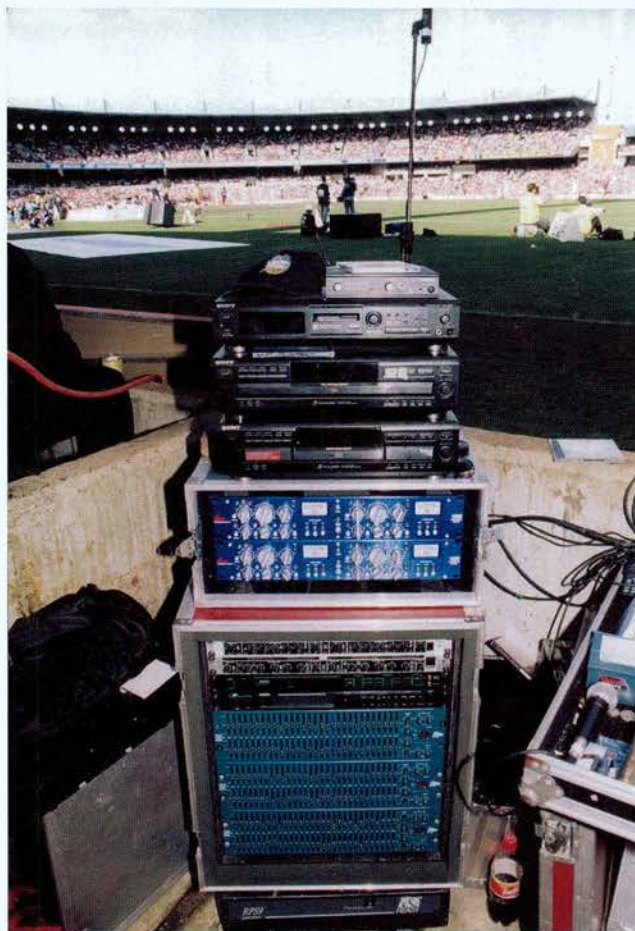

BROWN'S

PRECISION WELDING PTY LTD

ALLOY TRI TRUSS • BOX TRUSS • CIRCULAR TRUSS
20 YEARS EXPERIENCE • AUSTRALIAN MADE
ENGINEER APPROVED

Quality assured competitive prices

56 Mologa Road, West Heidelberg VIC 3081
Ph (03) 94552899 Fax (03) 94575044
Mobile 0412 401 469

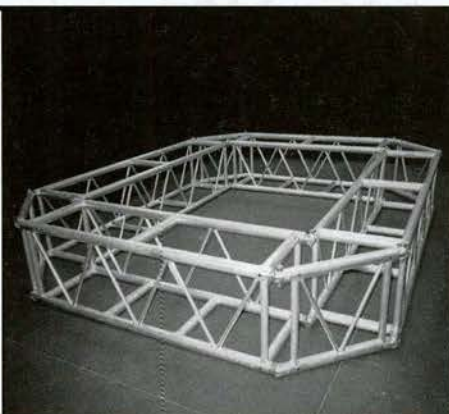

EV **N/DYM**[®]

WIRELESS

Featuring **ClearScan**[™]
Auto Channel Select

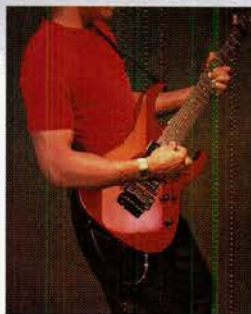

The N/DYM[®] UHF wireless is a 10-channel UHF frequency-agile system that provides professional-quality performance at a truly amazing price. N/DYM[®] wireless also features the latest in wireless technical innovations – **ClearScan**[™] auto channel select.

ClearScan[™] greatly simplifies system setup by automatically scanning and selecting a clear channel for trouble-free operation. The handheld systems feature EV's famous N/DYM[®] elements for great sound and performance. The N/DYM[®] wireless series from EV sets the new standard for wireless system performance and value.

EV **EVERYWHERE**[™]

www.eviaudio.com.au

EV **AUDIO**
A division of Telex Communications Inc.

Head Office: Tel 61 2 9648 3455
Victorian Office: Tel 61 3 9796 7777

(from page 8)



Sanyo PLC-XU22N



Panasonic PT-L759E



Barco 6400



JVC G11U

crisp, clear and stable. This projector is very good contrast, brightness and colour saturation just sealed the choice above its closest rivals.

The Sanyo PLC-XU22N retails at US \$7995

Portables B (less than 30lbs and greater than 1500 lumens)

My pick for this bunch of projectors was the **Panasonic PT-L759U**. The thing that underlined this device amongst a large range of very similar projectors was its excellent contrast and colour saturation.

Although this range of projectors contained two Panasonic devices, I deliberately chose the newer, cheaper PT-L759U over the older PT797PXU because of its superior colour balance during the shootout. The Panasonic PT-L759U retails at US\$10,995

Fixed Projectors (greater than 30lbs and less than 4000 lumens)

Although only a small range of projectors, this was the hardest projector to pick. I picked the **Barco 6400 DLC** over the rest - but it was a very close contest. They all had very good image clarity, colour saturation, brightness and contrast. Essentially, it came down to colour balance and detail clarity. With a resolution of 1280x1024 this projector is an exceptional LCD device. The Barco 6400 DLC retails at US\$28,490.

High Definition for Home and Business

The pick of the devices in this diverse category was the **JVC DLA-G11U**. It is a 1280x1024, D-ILA projector. This category had a wide range of projectors - some of which were staggeringly outclassed. The JVC projector was definite pick of the bunch, showing HD pictures with exceptional quality.

The JVC projector retails at US\$10,995.

How the choices were made

These choices are purely subjective, based on how the projector "looked" at the shootout. Things that were high on the list for consideration were any introduced digital artefacts on high resolution pictures, contrast, brightness, colour balance, black/white levels, colour saturation and image detail or crispness.

Each projector was fed the same signal courtesy of Crestron control and Extron distribution equipment. Due to the fact that LCD/DLP/D-ILA chips are all reaching such high standards it is very often the optics and signal processing in any given projector that defined how well it compared against its compatriots. The quickest way to eliminate projectors in most categories was to look for jitter in high contrast test patterns. In the first three categories, this test alone eliminated more than half of the field.

Unfortunately it was hard to judge contrast and black levels in some projectors as the limited overhead lighting directly affected some screens and not others.



METEORLITES

DESIGNER MIRROR BALLS



LIGHTING HIRE AND SALES

EAST COAST OFFICE OPENING IN JULY

Watch this space for details
Phone 1800 178 111 for more info

Head office:

294 Aberdeen Street, West Perth, WA 6005

Ph: (08) 9227 5590 Fax: (08) 9398 5501

Email: mudlark3@iinet.net.au

Web: www.iinet.net.au/~mudlark3

Established 1992

Focus On Projection



JVC DLA-M4000LU



Panasonic PT-D9600U



Digital 5SX

Large Audience Projection 4:3 - High Output (lumens between 4000 and 8000)

This was another category that was very hard to pick. Ultimately, the choice came down to the **JVC DLA-M4000LU**. This was the most interesting thing about this category was the side by side comparison of three different projection technologies. The LCD, DLP and D-ILA projectors were all very impressive. The DLP projectors largely fell down because they were 1024x768 projectors. Surprisingly, the LCD projector (Sharp XG-V10WU) looked equally as good as the JVC despite it being half the price. Where the JVC projector edged out the Sharp one was in the blacks and the crispness of ultra-fine detail. The JVC DLA-M4000LU has a native resolution of 1280x1024 and retails at US\$69,990.

Large Audience Projection 4:3 - Very High Output (lumens above 8000)

This is the high end of video projection, and **Panasonic's PT-D9600U** was the best device on the day against two other very impressive projectors. It is a 1280x1024, DLP projector with a very sharp picture output, excellent contrast and no identifiable digital distortion.

I am not entirely sure why this category exists separate to the 16:9 category, as the projectors in one category could easily be placed in the other. The Panasonic PT-D9600U has retail price of US\$175,000.

Large Audience Projection 16:9

The **Digital Projection 6SX** was the projector of choice in this category. With a

resolution of 1280x1024 this DLP projectors output is very impressive, and could be easily mistaken for film by the general public. With digital cinema one of the hottest topics amongst the big projector manufacturers, expect to see new projectors in this category from almost every major manufacturer. Interestingly, it was impossible to pick a clear winner in this category by the picture alone. The Panasonic PT-D9600U is easily the equal of the Digital Projection device. What clinched the choice for me was the fact that the Panasonic device was almost US\$70,000 more expensive. The Digital Projection 6SX is a 1280x1024 DLP projector and it retails at US\$98,990.

Projecting 16:9

No projector can quite display the full 1080 lines required for true HD pictures - yet. High Definition in the ratio of 16:9 means that a 1280x1024 projector can only use 1280x720 pixels to project in 16:9. The next resolution down (a 1024x768 projector) only uses 1024x576 pixels to project 16:9. Projectors that are "HD ready" are capable of interpreting and scaling HD format pictures, and then projecting the result. A true HD 16:9 projector would require a pixel ratio of at least 1920x1080. Both JVC and Texas Instruments are looking to develop chips capable of this resolution or better, which will make the next generation of DLP, D-ILA and LCD very interesting indeed.



34 busses

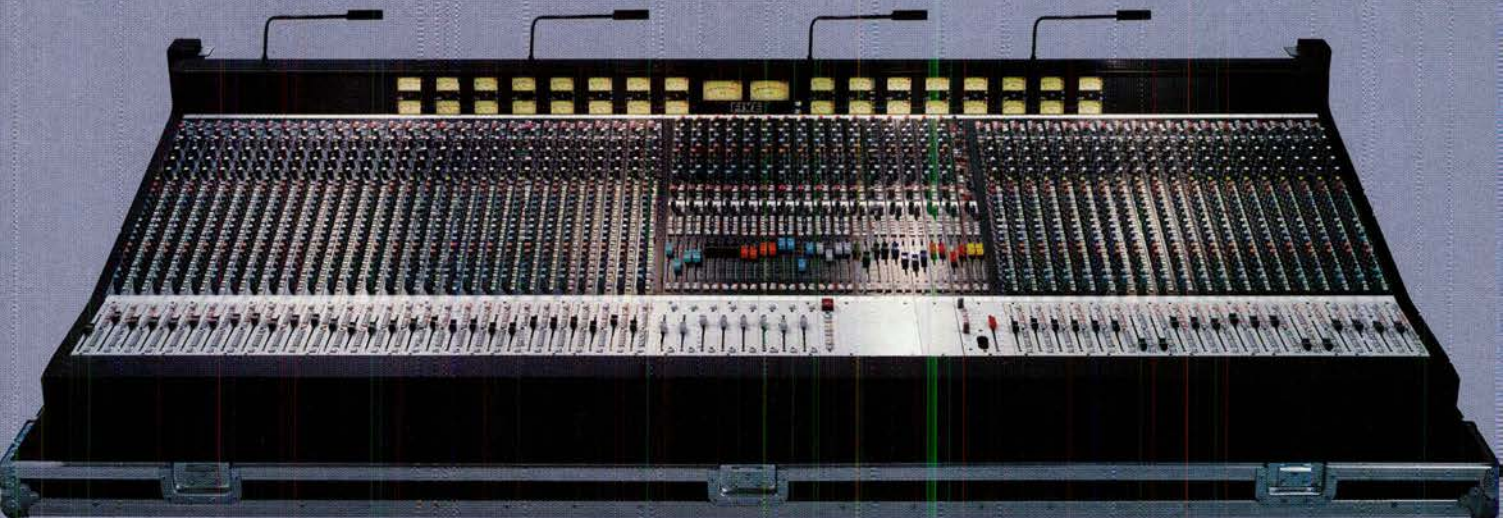

(for a variety of drivers)

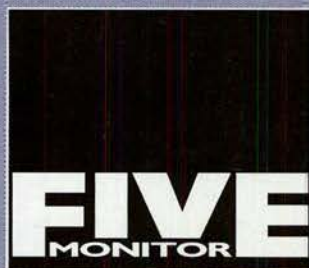

Monitor Mixing. The most complex, nerve-racking and thankless job in live sound. And the one with the most discerning audience. Don't even think about attempting it without the right equipment: **Soundcraft's FIVE Monitor.**

Designed for engineers who demand the best, **FIVE Monitor** offers a **34 bus** capability with the flexibility to accommodate almost any combination of in-ear and wedge operation.

Its unique qualities have already put it at the top of leading equipment lists including those of Shania Twain and Celine Dion.

And, available in frame sizes up to 56 channels, with optional stereo mic inputs and a 28 channel extender also available, it should be top of your list too.



www.soundcraft.com

Jands Electronics Pty Ltd
Phone (02) 9582 0909 Fax (02) 9582 0999
40 Kent Road Mascot NSW 2020
www.jands.com.au

 **Soundcraft**

H A Harman International Company

I've got 1,000 books in stock NOW! -Julius Grafton

THESE ARE IN STOCK NOW!

• PRICES NOW INCLUDE AUSTRALIAN GST

AUDIO WORKSTATION HANDBOOK Francis Rumsey	\$82
A-Z OF LIGHTING TERMS Brian Fit	\$60
BASICS OF VIDEO LIGHTING Des Lyver/Graham Swainson	\$38
BASIC STAGE LIGHTING Mark Carpenter	\$18
CONCERT LIGHTING James Moody	\$77
CONCERT TOUR PRODUCTION MGMT John Vasey	\$42
CONTROL SYSTEMS FOR LIVE ENTERTAINMENT John Huntington	\$120
CREATING SPECIAL EFFECTS FOR TV AND VIDEO Bernard Wilkie	\$40
EFFECTIVE AUDIO VISUAL Robert Simpson	\$88
EFFECTS FOR THE THEATRE Edited by Graham Walne	\$53
ESTA ETHERNET GUIDE	\$38
GAFFER'S HANDBOOK Harry C. Box	\$99
HUMS & BUZZES EXPLAINED Laurie Nethercote	\$9
LIGHTING AND SOUND Neil Fraser	\$31
LIGHTING STENCIL SET from KILOWATT CO	\$99
LIGHTING TECHNOLOGY H'BOOK Brian Fit/Joe Thornley	\$124
LIGHTING THE STAGE Francis Reid	\$44
LIVE SOUND MIXING Duncan Fry	\$41
MAKING MUSIC WITH YOUR COMPUTER David (Rudy) Trubitt	\$20
MAKING THE ULTIMATE DEMO Michael Molenda	\$27
MIDI SYSTEMS & CONTROL Francis Rumsey	\$60
MIX TEST CD DELUXE EDITION	\$77
MOBILE DJ HANDBOOK Stacy Zemon	\$49
MODULAR DIGITAL MULTITRACKS George Petersen	\$27
MUSIC & TECHNOLOGY H.P. Newquist	\$31
MUSIC PRODUCERS MIX Magazine	\$20
PRACTICAL STUDIO TECHNIQUES (with CD) Tom Misner	\$44
PROJECTION FOR THE PERFORMING ARTS Graham Walne	\$88
RECOMMENDED PRACTICE FOR DMX 512 Adam Bennette	\$20
SET LIGHTING TECHNICIAN'S HANDBOOK Harry C. Box	\$82
SOUND & MUSIC FOR THEATRE Kaye & LeBrecht	\$48
SOUND FOR PICTURE MIX Magazine	\$20
STAGE DESIGN & PROPERTIES Michael Holt	\$31
STAGE LIGHTING CONTROLS Ulf Sandstrom	\$97
STAGE LIGHTING HANDBOOK Francis Reid	\$42
STAGE MANAGEMENT & THEATRE ADMINISTRATION Pauline Menear/Terry Hawkins	\$31
STAGES FOR TOMORROW Francis Reid	\$41
STUDIO BASICS Richard Mansfield	\$37
TECH TERMS George Petersen/Steve Oppenheimer	\$20
THE BEST OF DUNCAN FRY	\$13
YAMAHA SOUND REINFORCEMENT HANDBOOK Gary Davis/Ralph Jones	\$75

For more info on the above titles, visit www.conpub.com.au or call Sarah on 1-800-635-514 or +61 2 9876-3530 or fax +61 2 9876-5715 and we will send OR FAX you the webpage with full description!

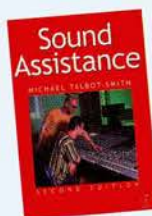

SOUND ASSISTANCE,
2nd edition \$56

By Michael Talbot Smith. Offers an easy-to-understand account of sound operations in radio and television studios. New edition covers microphone sensitivities, loudspeaker listening tests, stereo transmission in radio, stereo PPM interpretations, MiniDisc, and more. 250 pgs, 1999.

**PRACTICAL ART OF
MOTION PICTURE
SOUND (with CD),**
2nd edition \$84

By David Lewis Yewdall, MPSE. This book features such topics as: Pre-production planning, production tips, temp dubs and test screenings, custom recording sound effects, dialog editing, non-linear editing, music in film and television. The audio CD contains sound-effects and demonstration material. 265 pgs, 1999.

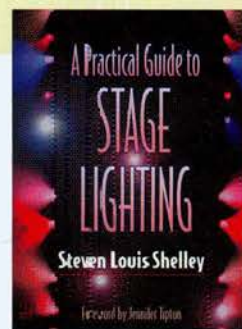
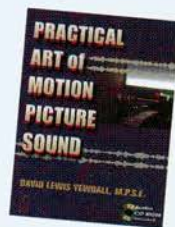

A practical guide to stage lighting \$80

By Steven Louis Shelley, Forward by Jennifer Tipton. 280 pages, Extensive charts, diagrams and plots, EXCELENTLY LAID OUT, Heaps of tips, tricks and traps for young players! First published 1999. Fresh!

"Our best book for anyone who needs to get their HANDS ON a lighting rig." Julius Grafton, Connectors.

CALL Freecall 1800-635-514 to place your order or visit www.conpub.com.au



PROJECT STUDIOS, a more professional approach \$84

By Philip Newell. With a boom in so called 'bedroom studio' operations, lack of experience can lead to bad recording practices and an inability in getting the best performances from musicians. This book provide tips and advice on getting first class, professional results from project studio equipment. 274 pgs, 2000.

ON-LOCATION RECORDING TECHNIQUES
\$64

By Bruce Bartlett, with Jenny Bartlett. Focuses exclusively on the special techniques used for recording outside the confines of a studio. Offers a clear explanation of stereo miking theory, along with specific techniques, procedures and hardware. Also covers mixing and editing a live gig tape, building a recording truck, surround-sound miking, binaural and transaural stereo. 278 pgs, 1999.

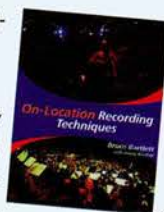

**THE MIDI
MANUAL** 2nd
Edition \$64

By David Miles Huber. The book provides a close-up look at the industry's top products and teaches you how to integrate them with your computer. Illustrations and step-by-step lessons teach you how to set up an efficient MIDI system as well as how to use your PC to expand your musical recording and performance techniques. 255 pgs, 1999.

All prices in Austral. dollars. Add freight for each order. Prices may change at any time of course! Current as of June 30, 2000. An activity of Connections Publishing F/.. (ACN 058443182), PO Box 409 Epping NSW 2121

RICKY MARTIN



All pix © Diana Scrimgeour

Livin' La Vida Loca World Tour

Total Production magazine's Mark Cunningham shakes his bon-bon (whatever that is) as the Latino song and dance sensation makes a flying visit to London, a head of his tour of Asia and Australia



Is that a Sony 840 mic I see before me?

As TP walked into Earl's Court arena, two things became blindingly apparent. Firstly, this was very much a sponsored tour - you couldn't move for Pepsi and Giorgio Armani logos. Secondly, the aroma of uncensored lust emanating from the horces of turned-on women was the tell-tale sign that this could only be the place where Ricky Martin was about to make his first headlining concert appearance in Britain.

Titled after his worldwide mega-hit, the *Livin', La Vida Loca* world tour production could be simply described as nothing more and nothing less than ultra-sophisticated, high-tech cabaret. Which, judging by the stylistic aspects of most of today's hottest tickets, is what more audiences seem to prefer (or expect) these days.

Hi-Tech Cabaret

Ricky Martin is a shrewd guy who has arrived just in time to ride the crest of a Latino/Salsa tidal wave (I'd wager that Carlos Santana can't believe his own current run of luck). From the moment he burst on to the stage in a battered, 65 Mustang, Martin shook his tight leather-trousered ass for all it was worth. And, like a man whose crotch is being besieged by a pack of hungry ferrets, he doesn't stop.

We had a pretty good vantage point at the Earl's Court show quite literally rubbing shoulders on the FOH riser with Madonna. And there behind his usual Amek Recall desk was Rob 'Cubby' Colby - a man who is used to taming the excitement of Earl's Court acoustics, but maybe fighting a losing battle to get over the top of something like 115d3 (A weighted)



Monitor engineer Raphael Alkins with the ATC Peragon II console (left). The V-Disc rig was powered by QSC PowerLight 9.0PFC and 4.0 amps.



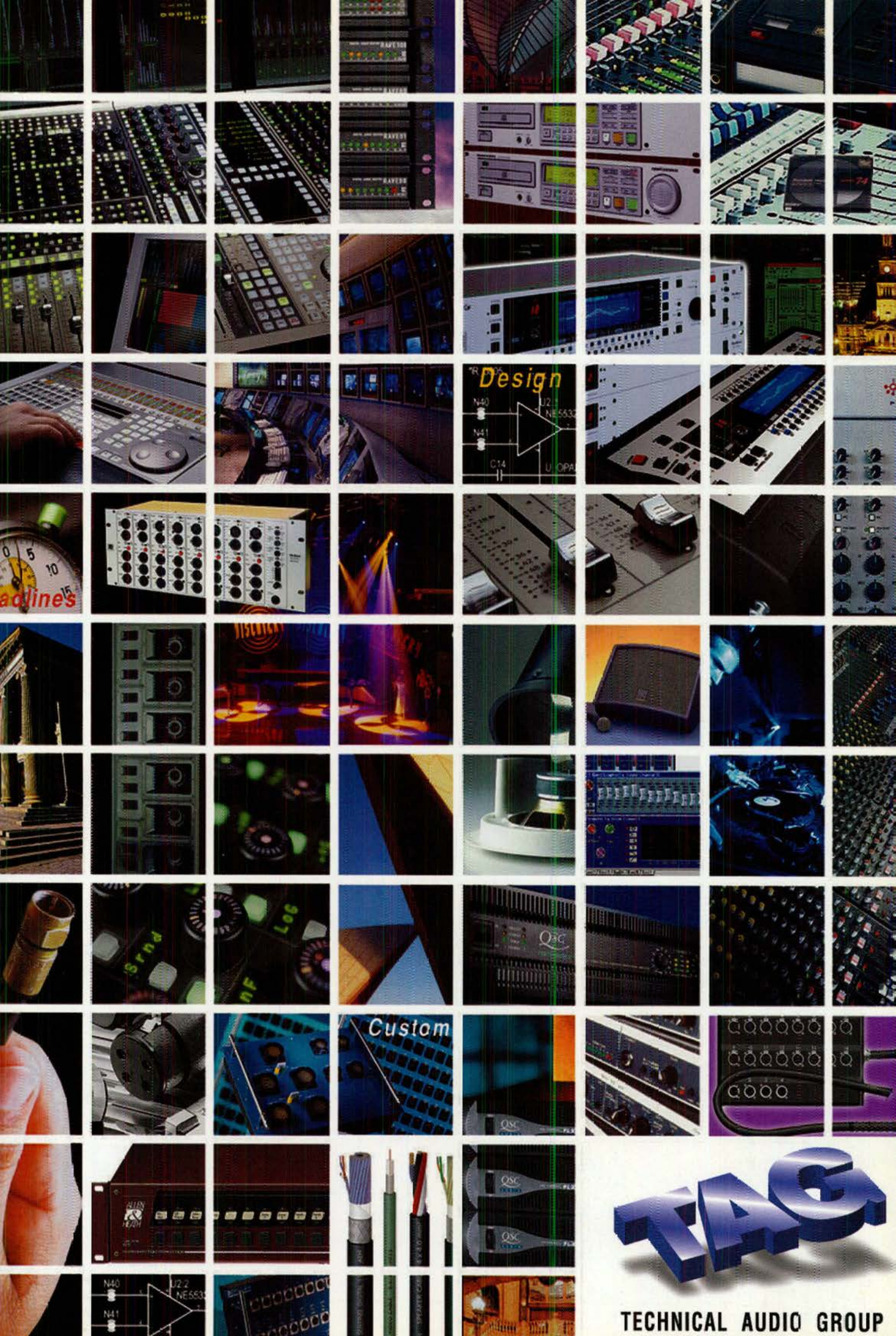

Custom

TAG

TECHNICAL AUDIO GROUP



Euphonix Flagship:

96kHz 24 Bit all digital Euphonix S5 leaves no moving fader unturned in its quest for audio perfection. Page 14



Marantz Broadcast CD Players:

All new fully featured CD Players with RAM Buffer, Jog Shuttle Wheel, Back-Lit Transport Buttons, Instant Start etc, etc. PMD330/331/340. Page 20



Flash RAM Portable Recorders:

With the combination of shock resistant recording, internal editing and electronic file transfer, Flash RAM is ideally suited to field recording. Marantz PMD 690. Page 20



Wavefront 8 Longthrow™

Martin Audio's new LongThrow™ cabinets eliminate the need for delay speakers in large outdoor festival, stadia & arena systems. Page 22

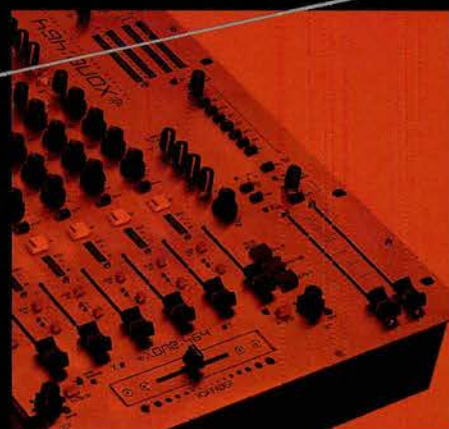

A&H Xone Club Mixers:

Premium grade consoles for venues and DJ's, fully equipped with VCA Cross-Fader, VCF Filter and Stainless Steel construction. Page 6



PowerLight 2:

QSC have updated the Multi-ENTECH Award winning PowerLight: more features, smaller size, lower cost! Page 27



A&H Dual Function Touring Console:
Featuring 6 VCA's, 16 Aux, 8 Groups, LCR & IEM.
ML5000 Page 4



Martin Audio BlackLine™
All new range of live and installation speakers incorporating
legendary Martin Audio performance. Page 23



Price Sensitive QSC:
The RMX series re-packs the 'Power, Performance, Price'
equation. QSC Quality, Service, Commitment at a surprising
price. Page 27

Contents

Allen & Heath	4
ATC	8
Amphenol	9
Klotz Cable	10
Cinde	12
Euphonix	14
LA Audio	16
Marantz	20
Martin Audio	22
QSC Audio	26
SST	31

All prices include GST & are effective from 1st July 2000.



TECHNICAL AUDIO GROUP

558 Darling Street, Balmain NSW 2041, Australia.
GPS: Lat 33°51'35S: Lcn 151°10'19E
Phone: + 61 (02) 9810 5300
Fax: + 61 (02) 9810 5355
Email: info@tag.au.com
Web: www.tag.au.com

ML5000: Large Format VCA LCR Touring Console

ML5000 puts A&H firmly in the large touring console market. Designed to shake the established order, it's an 8 VCA, 16 Aux, 8 Group, enhanced LCR and IEM equipped big-league console in a compact package. As with the GL Series the ML5000 is a dual function design with a stack of capabilities for both FOH and Foldback. In FOH mode: 8 audio groups, 8 VCA groups with scene automation, 16 auxes, 8-way matrix and a unique two pot LCR-Plus panning system to enable full speaker balancing and positioning for each channel or group. In Monitor mode: 16 aux mixes (with aux 9-16 optionally paired for stereo IEM feeds), plus left and right outputs, all with faders, inserts, talkback and metering and an engineers wedge monitor listen on the centre fader. The channel strip features 4 band parametric EQ with sweepable 'Q' on the mids and in/out switching. Further details at the dedicated site: www.ML5000.com.

ML5000-32	\$49,995.00
32 Mono + 4 Stereo Ins • 8 Group • 16 Aux • 8 VCA • LCR Touring Console	
ML5000-40	\$56,995.00
40 Mono + 4 Stereo Ins • 8 Group • 16 Aux • 8 VCA • LCR Touring Console	
ML5000-48	\$63,995.00
48 Mono + 4 Stereo Ins • 8 Group • 16 Aux • 8 VCA • LCR Touring Console	
ML5000-24C	\$28,995.00
24 Mono Input SideCar Extender incl RPS14 Power Supply	
MPS14	\$3,395.00
POWER SUPPLY/COMBINER: One Supplied with Console • 3RU	

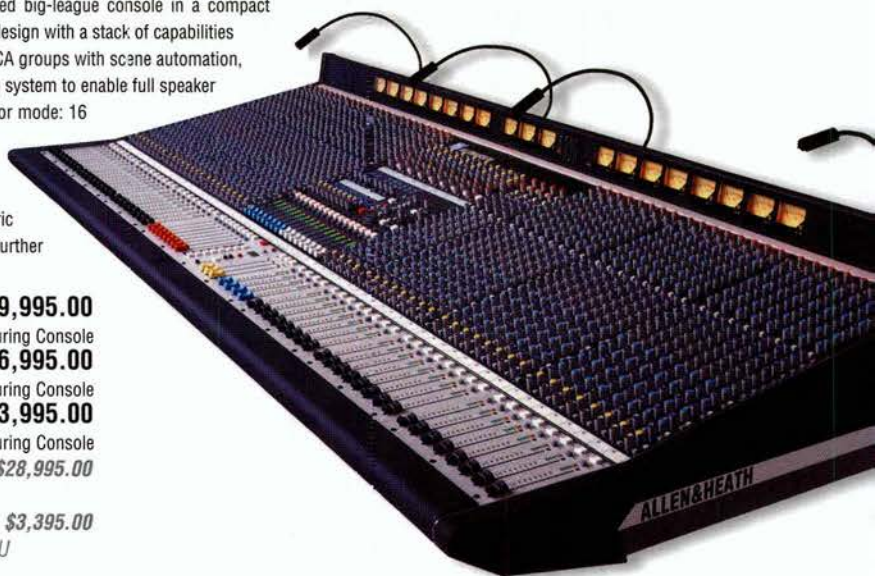

GL 4000: 8 Group FOH/Monitor/Dual Function Touring Console

8 Group FOH or 12 Send Foldback or 8 Group/10 Auxiliary Dual Role Console. Features 4 band full sweep EQ with 'Q' control on the mids, 8 instant access mute groups + 128 mute scenes with MIDI control, 10 auxiliaries on faders, 10x4 matrix, direct outs with level control on each channel, with control on stereo channels (from reverse through normal to wide), stereo channels with mic pre amps, comprehensive metering on all channels/groups/outs, 8 track recording facility, 100mm ALPS faders, individual Phantom Power on all mono channels, insert points on all mic inputs/group outs/LR, mutes on all inputs/groups/auxiliaries/LR&M, Wedge Listen facility, individual channel PCB's, integral meter bridge. SYS-LINK™ compatible. Available in 4 formats: Format A: all mono channels. Format B: 4 stereo channels directly to the right of the centre section. Format C: 4 stereo channels at the far right of the console. Format D: 8 stereo channels at the far right of the console. Call for pricing on formats A to D.

RPS11	\$2,395.00
POWER SUPPLY: One Supplied with Console • 3RU.	
RPSD-2	\$1,895.00
DUAL POWER SUPPLY MONITOR: Automatic Switching Unit for Connection of Two PSU's to GL4000 Console • 1RU.	
GL4000/SL-1	\$1,145.00
SYS LINK™ CARD: Internally Fitted Card For Each GL4000 (Excludes Cables)	



GL4000-24
\$21,495.00



GL4000-32
\$26,495.00



GL4000-40
\$31,495.00



GL4000-48
\$36,495.00

GL 3300: 8 Group FOH/Monitor/Dual Function Console



8 Group FOH or 10 Send Foldback or 8 Group/8 Auxiliary Dual Role Console. Featuring 4 instant access mute groups, optional stereo channels (with dual mic pre-amps), 4 band EQ with 2 mid sweeps, 8 auxiliaries, direct outs, 2 stereo returns, 11x2 matrix, comprehensive metering on all channels/groups/outs, 2 track record and replay, 100mm ALPS faders, individual Phantom Power on all mono channels, insert points or all mic inputs/group outs/LF, mutes on all inputs, individual channel PCB's, integral meter bridge (Except 16Ch), SYS-LINK™ compatible. Available in 4 formats: Format A: all mono channels. Format B: 4 stereo channels directly to the right of the centre section. Format C: 4 stereo channels at the far right of the console. Format D: 8 stereo channels at the far right of the console. Call for pricing on formats A to D.

GL3300-EGD

OUTPUT EXPANDER: 8 Group Output Option (On 'D' Connector)

GL3300/SL-1

SYS LINK™ CARD: Internally Fitted Card For Each GL3300 (Excludes Cables)

\$375.00

\$695.00

RPS9

POWER SUPPLY: One Supplied with Console. 2RU.

RPSD2

DUAL POWER SUPPLY MONITOR: Automatic Switching Unit for Connection of Two PSU's to GL3300 Console. 1RU.

\$1,595.00

\$1,895.00



GL3300/16
\$8,445.00



GL3300/24
\$11,495.00

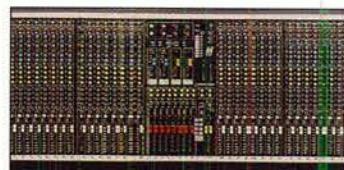

GL3300/32
\$14,495.00



GL3300/4J
\$17,995.00

GL 2200: 4 Group FOH/Monitor/Dual Function Console

Desktop console for live 4 Group FOH or 6 send Foldback or Dual Function applications. Features include 4 band EQ with two mid sweeps or mono channels, 6 auxiliaries, 2 stereo returns with EQ, direct channel outs, 2 track recording in and out, 100mm ALPS faders, 12v lamp outlet, line-up tone generator with Pink Noise and Sine Wave, individual Phantom Power on all mono channels, insert points or all mic inputs/group outs/LR, mutes on all inputs, individual vertical channel PCB's, external power supply, SYS-LINK™ compatible.

GL2200/SL-1

\$695.00

SYS LINK™ CARD: Internally Fitted Card for Each GL2200 (Excludes Cables)



GL2200/2
\$4,295.00

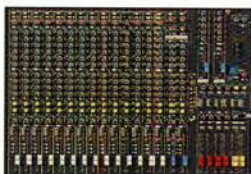

GL2200/16
\$4,995.00



GL2200/24
\$6,595.00



GL2200/32
\$8,195.00

MixWizard Series Mixing Consoles

Designed for a wider market than the GL Series Consoles, MixWizard combines traditional A&H quality and innovation at very competitive price points. MixWizard nonetheless includes all the equipment to do the job with rugged build quality, individual channel PCB's, 100mm Alps faders, Neutrik connectors and super-clean MSP (Minimum Signal Path) circuitry.

WZ16:2DX **\$3,395.00**

16 CHANNEL MIXING CONSOLE: 16 Mono Stereo Inputs • 4 Band EQ/2 Mid Sweeps • 6 Aux • 2 Stereo Returns • Inserts • Rotating Connector System • 100mm Faders • Direct Outs • Phantom • 2 Sets of L/R Outs with Level and Mono Sum • 10RU.

WZ 14:4:2+ **\$3,595.00**

14 CHANNEL DUAL FUNCTION FOH/FOLDBACK CONSOLE: 4 Sub-Groups • 10 Mono Stereo Inputs • 4 Band EQ+2 Mid Sweeps • 6 Aux • 4 Stereo Returns • Inserts • Rotating Connector System • 100mm Faders • Individual Direct Outs • Individual Phantom • SYS LINK™ Option • 10RU.

WZ14:4:2-SL1 **\$745.00**

SYS LINK™ CARD: Internally Fitted Card for WZ14:4:2 (Excludes Cables)

WZ20S **\$3,795.00**

20 INPUT BROADCAST/STEREO SOURCE CONSOLE: 4 Mono Dual Stereo Ins • 4 Band EQ (2 Mid Sweeps on Monos) • 6 Aux • 2 Stereo Mix Busses • Rotating Connector System • 100mm Faders with Fader Start Option • Individual Direct Outs • Phantom • SYSLINK Option • 10RU.



MixWizard Series

XONE Club/Disco Mixers

Premium quality consoles for professional venues and DJ's. Alongside luxury features like 4 band EQ and synth-style VCF filters, A&H have applied the same passion for outstanding audio and bomb-proof build.



Xone:464 **\$4,295.00**
16 INPUT CLUB INSTALLATION MIXER: 6 Stereo plus 4 Fully Featured Mic Ins • 4 RIAA Pre-Amps • VCF Filters • VCA Cross-Fader • 6 Aux • Stainless Steel Construction.



Xone:62 **\$2,995.00**
12 INPUT DJ MIXER: 6 Stereo Ins • 4 RIAA Pre-Amps • VCF Filters • VCA Cross-Fader • Stainless Steel Construction.





Digital Engines

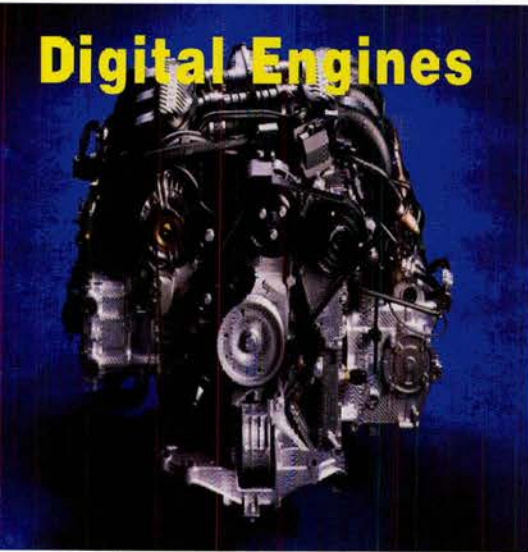

Live Mixers

The ICON range of digital live mixers are targeted at AV and production companies as well as performing artists and live sound venues. ICON users can program and recall settings in patches which can then be sequenced according to a playlist and triggered by footswitch, pushbutton or MIDI control. A special Pause Patch sets levels, FX etc. for between patch requirements such as introductions, announcements, speeches etc.

DL1000 **\$3,495.00**
 DIGITAL MIXER: 6 Mono Mic+2 Stereo Inputs with 4 Band Sweep EQ (2 Fully Parametric Mids) • Noise Gates & Compressors • 2 Sets of L/R Outs • Two Effects Processors with Adjustable Presets • Dual 10 Band EQ with Venue Memories • 100mm Faders • Phantom plus plus.

DP1000 **\$4,495.00**
 POWERED DIGITAL MIXER: As Above Including Two Channel 300w/ch Power Amplifier.

Installation Series

Rack mount system with full mixing/DSP processing/matrixing capabilities. Both DR units offer optional selectable processing on each channel: 31, 15, 7 band graphic EQ, 4 or 2 band parametric EQ, ducker, gate, delay, crossover, compressor, limiter plus matrix mixing facility and presets on touch button on front panel for system reconfiguration. System control is via front panel menu (with password protection) or computer control. For timed events a real-time clock can actuate recorded messages or change presets. For Alarm/Emergency Warning DR units can be operated by back-up battery 24v power supply. DSP processing can be increased with extra cards.

DR128 **\$6,995.00**
 DIGITAL AUDIO MIX PROCESSOR: 12 In/8 Out Rack Mount Mixer • 8 Mic/4 Line Ins • 8 Balanced Outs • 12 System Presets on Touch Button Front Panel • 2RU

DR128-DSPx **\$1,595.00**
 DIGITAL PROCESSOR CARD: As DR66-DSPx

DR128-DSPd **\$1,595.00**
 DIGITAL DELAY CARD: As DR66-DSPd

DR128-NET **\$745.00**
 SYS-NET OPTION: For third party remote control via RS232

DR66 **\$3,995.00**
 DIGITAL AUDIO MIX PROCESSOR: 6 In/6 Out Rack Mount Mixer • 2 Mic/4 Line Ins • 6 Balanced Outs • 8 System Presets on Touch Button Front Panel • 1RU.

DR66-DSPx **\$1,595.00**
 DIGITAL PROCESSOR CARD: Plug-In DSP triples the Processing Capability of standard DR66 • Maximum of two DSPx can be used on each DR66 (DR66 + DSPx + DSPx).

DR66-DSPd **\$1,595.00**
 DIGITAL DELAY CARD: Plug-In Card for DR66 Delay options • One DSPd can be used on each DR66 • Maximum Processing DR66 + DSPx + DSPx + DSPd.

DR66-NET **\$745.00**
 SYS-NET OPTION: For third party remote control via RS232

Rack Mount Zone Mixers

Analogue installation mixers combining maximum flexibility with operator ease for Pubs, Restaurants, Churches, Retail, Hotels, Theatres etc. GF Series can be expanded via SYS-INK to other GR or A&H units and are remote controllable. For Alarm/Emergency Warning GR units can be operated by back-up battery 24v power supply.



GR-1 **\$2,295.00**
 3-BUSS INSTALLATION MIXER: 6 Mic Ins with Priority Ducking • 3 Stereo + 2 Mono Line Ins • Left, Right and Mono Balanced Outs • Internal Set Routing • Ducking • Compressor/Limiter • Phantom Power • Alarm Source • Remote Control • 1RU.

Multi-Channel Power Amplifier

GR-8A **\$2,995.00**
 8 CHANNEL INSTALLATION AMPLIFIER: 8 Ch of 60 Watts/Ch @ 4Ω or 4 Ch of 120W @ 8Ω • Headphone monitoring (Every Channel) • XL3 Ins • 3-Colour Input Meters • 24v Battery Backup • Level Control 'Lock-Out' • Remote Control STANDBY Operation • 3-Speed Fan • 2RU.

GR-05 **\$1,345.00**
 4 ZONE MATRIX MIXER: 2 Mic Ins with Priority Ducking & EQ • 3 Stereo Line Ins • 4 Mono Balanced Outs with 3-Colour LEDs • Remote Volume • Internal Set Matrix • EQ • Routing • Ducking • Zone Control • Phantom Power 1RJ.

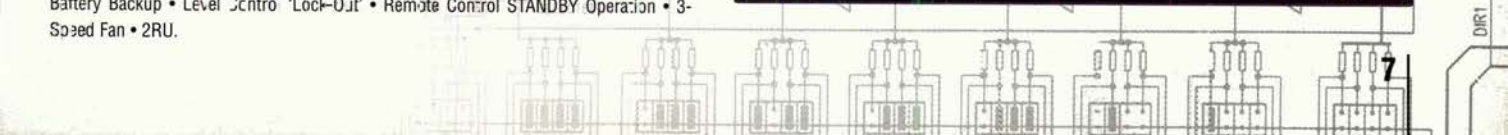
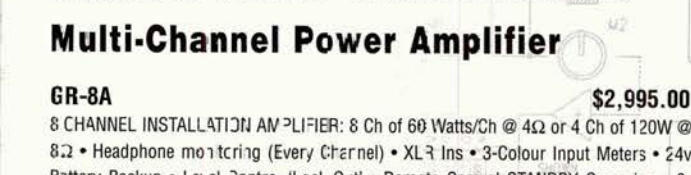

Two-Way Passive Nearfield Monitors

SCM10 PRO **\$3,795.00**
 NEARFIELD PASSIVE 2-WAY CONSOLE-TOP MONITOR: 5" Soft Dome Mid/Bass with 1" Soft Dome HF • 100-300w Amplifier Recommended • Studio Grey Finish • 10Kg.

SCM20SL PRO **\$5,995.00**
 NEARFIELD PASSIVE 2-WAY CONSOLE-TOP MONITOR: 6.5" Soft Dome Mid/Bass with 1" Soft Dome HF featuring SL (Super Linear) Magnetic Materials to further eliminate distortion • 100-300w Power Amplifier Recommended • Studio Grey Finish • 23Kg.

Two-Way Active/Powered Nearfield Monitors

SCM20A PRO **\$11,495.00**
 ULTIMATE PORTABLE MONITOR: As SCM20SL PRO but with Aircraft Alloy Construction Cabinet featuring Integral Amplifiers (250w Mid/Bass, 50w HF), Heat-Sink, Carry Handle and OmniMount Fixings • Reference Flat and Bass Boost Control • 30Kg.

Powered Sub-Woofer

SCM0.1/15PRO **\$11,995.00**
 SINGLE 15" 1000W SUB-WOOFER: ELF for 5.1/7.1 Multi-Channel Systems or Addition to SCM10/20/50 • Features SL Magnet Technology • 118dB Continuous SPL • 30-300Hz • Integral Amplifier • Compatible for Dolby AC3 • +/-6dB Trim • Studio Grey Finish • 90Kg.



Three-Way Active/Powered/Midfield/Main Monitors

3-Way Precision Reference Monitors featuring Active Crossover and Tri-Amplifier Packs: 200w Bass, 100w Mid, 50w HF. All three models use 3" Voice-Coil Super-Dome Mid with 1" Soft Dome HF. Gain Reduction Warning Panel and HF Unit are interchangeable for positioning the monitors either Horizontally or Vertically. Reference Flat and Bass Boost Settings. Studio Grey Finish.

SCM50A PRO **\$21,495.00**
 ACTIVE 3-WAY MONITOR: 9" SL Bass Driver • 50 Litre Enclosure • 112dB (1m) Continuous SPL • Cut-off Frequencies Free-Standing (-6dB) 38Hz - 20kHz • 49Kg.

SCM100A PRO **\$24,445.00**
 ACTIVE 3-WAY MONITOR: 12" SL Bass Driver • 100 Litre Enclosure • 115dB (1m) Continuous SPL • Cut-off Frequencies Free-Standing (-6dB) 32Hz - 20kHz • 65Kg.

SCM150A PRO **\$27,995.00**
 ACTIVE 3-WAY MONITOR: 15" SL Bass Driver • 150 Litre Enclosure • 117dB (1m) Continuous SPL • Cut-off Frequencies Free-Standing (-6dB) 25Hz - 20kHz • 75Kg.

Three-Way Active Main Monitors

3-Way Precision Reference Monitors including SPA24-850 Crossover /4-Way Amplifier Pack: 257+275w Bass, 200w Mid, 100w HF. Both models use 3" Voice-Coil Super-Dome Mid with 1.25" Soft Dome HF. Studio Grey.

SCM200A PRO **\$55,995.00**
 ACTIVE 3-WAY MAIN MONITOR SYSTEM: Double 12" SL Bass Drivers • 200 Litre Enclosure • 118dB (1m) Continuous SPL • Cut-off Frequencies Soffit Mounted (-6dB) 25Hz - 20kHz • 116Kg.

SCM300A PRO **\$65,995.00**
 ACTIVE 3-WAY MAIN MONITOR SYSTEM: Double 15" SL Bass Drivers • 300 Litre Enclosure • 121dB (1m) Continuous SPL • Cut-off Frequencies Soffit Mounted (-6dB) 20Hz - 20kHz • 140Kg.

L/C/R Active Main Monitor Systems

SCM200A LCR **\$94,995.00**
 ACTIVE MAIN MONITOR LEFT/CENTRE/RIGHT SYSTEM: Includes three SCM200A PRO's and two SPA24-850 Amplifier Packs • Studio Grey Finish.

SCM300A LCR **\$104,995.00**
 ACTIVE MAIN MONITOR LEFT/CENTRE/RIGHT SYSTEM: Includes three SCM300A PRO's and two SPA24-850 Amplifier Pack • Studio Grey Finish.



3-Pin Line Connectors with 'Jaws' Cable Clamp

AC3F	\$3.85
3 PIN FEMALE LINE CONNECTOR: For Cable OD 3-6.5mm • Zinc Finish.	
AC3M	\$3.15
3 PIN MALE LINE CONNECTOR: Pressed Metal Pins • Cable OD 3-6.5mm • Zinc Finish.	
AC3MM	\$3.65
3 PIN MALE LINE CONNECTOR: With Solid Metal Machined Pins • Cable OD 3-6.5mm • Zinc.	

AC-NUT	\$0.50
COLOURED NUT/BOOT: Blue, Brown, Green, Grey, Orange, Red, Violet, White, Yellow	
AC-NUT-AL	\$4.95
METAL NUT/BOOT: Aluminum (Black) For Heavy Duty Applications	
AC**-B	\$0.50
BLACK VERSION OF AC3 CONNECTORS: Additional Per Connector	

3-Pin Panel Connectors 'D' Size (Square Format)

AC3FDZ	\$3.95
3 PIN FEMALE PANEL CONNECTOR: 'D' Size • Zinc Finish.	
AC3MDZ	\$3.15
3 PIN MALE PANEL CONNECTOR: 'D' Size • Zinc Finish.	

AC3MMDZ	\$3.65
3 PIN MALE PANEL CONNECTOR: Solid Pin version of AC3MDZ • Zinc Finish.	
AC**-B	\$0.50
BLACK VERSION OF AC3 CONNECTORS: Additional Per Connector	

4 And 5 Pin Connectors

AC4F	\$7.75
4 PIN FEMALE LINE CONNECTOR: Zinc Finish.	
AC4M	\$5.75
4 PIN MALE LINE CONNECTOR: Zinc Finish.	
AC4FDZ	\$8.95
4 PIN FEMALE PANEL CONNECTOR: 'D' Size (Square) • Zinc Finish.	
AC4MDZ	\$5.55
4 PIN MALE PANEL CONNECTOR: 'D' Size (Square) • Zinc Finish.	

AC5F	\$9.95
5 PIN FEMALE LINE CONNECTOR: Zinc Finish.	
AC5M	\$7.25
5 PIN MALE LINE CONNECTOR: Zinc Finish.	
AC5FDZ	\$11.95
5 PIN FEMALE PANEL CONNECTOR: 'D' Size (Square) • Zinc Finish.	
AC5MDZ	\$8.75
5 PIN MALE PANEL CONNECTOR: 'D' Size (Square) • Zinc Finish.	

3-Pin Panel Connectors 'P' Size (Rectangular)

AC3FPZ	\$4.30
3 PIN FEMALE PANEL CONNECTOR: 'P' Size. Zinc. Off-set Holes/Top Left & Bottom Right.	

AC3MPNZ	\$3.45
3 PIN MALE PANEL CONNECTOR: 'PN' Size. Zinc Finish. Vertical Holes.	

EP Series Connectors

EP-4-11P	\$23.95
4 PIN FEMALE LINE EP SERIES CONNECTOR: Zinc Finish.	
EP-4-12	\$18.25
4 PIN MALE LINE EP SERIES CONNECTOR: Zinc Finish.	
EP-4-13P	\$19.95
4 PIN FEMALE PANEL EP SERIES CONNECTOR: Zinc Finish.	
EP-4-14	\$13.25
4 PIN MALE PANEL EP SERIES CONNECTOR: Zinc Finish.	
EP-5-11P	\$26.95
5 PIN FEMALE LINE EP SERIES CONNECTOR: Zinc Finish.	
EP-5-12	\$19.25
5 PIN MALE LINE EP SERIES CONNECTOR: Zinc Finish.	
EP-5-13P	\$22.25
5 PIN FEMALE PANEL EP SERIES CONNECTOR: Zinc Finish.	
EP-5-14	\$14.25
5 PIN MALE PANEL EP SERIES CONNECTOR: Zinc Finish.	

EP-6-11P	\$28.95
6 PIN FEMALE LINE EP SERIES CONNECTOR: Zinc Finish.	
EP-6-12	\$20.25
6 PIN MALE LINE EP SERIES CONNECTOR: Zinc Finish.	
EP-6-13P	\$23.45
6 PIN FEMALE PANEL EP SERIES CONNECTOR: Zinc Finish.	
EP-6-14	\$16.25
6 PIN MALE PANEL EP SERIES CONNECTOR: Zinc Finish.	
EP-8-11P	\$25.25
8 PIN FEMALE LINE EP SERIES CONNECTOR: Zinc Finish.	
EP-8-12	\$20.25
8 PIN MALE LINE EP SERIES CONNECTOR: Zinc Finish.	
EP-8-13P	\$25.25
8 PIN FEMALE PANEL EP SERIES CONNECTOR: Zinc Finish.	
EP-8-14	\$17.95
8 PIN MALE PANEL EP SERIES CONNECTOR: Zinc Finish.	

Live Sound Reinforcement Multicore Cables

A premium multicore designed for live production companies. Each 16 x 0.14mm strand conductors are paired with a tinned drain wire, a copper spiral shield and a PUR numbered jacket. An overall tinned copper wire braided shield provides further isolation within a PUR overall jacket ■



PP1025 \$28.95

10-Way: 15.5mm OD

PP2025 \$51.95

20-Way: 20mm OD

Digital Cables and Digital Multicores

AEY122 \$3.25

Digital Transmission Cable: 4.5mm OD • PVC Jacket • Foil + Braided Screen • Drain Wire



OMNI_STAR 0S04P \$12.95

4-Way Digital: 9mm OD • PUR Jacket • Individual foil + Overall Braided Screen

OMNI_STAR 0S08P \$25.95

8-Way Digital: 14mm OD • PUR Jacket • Individual foil + Overall Braided Screen

OMNI_STAR 0S16P \$34.95

16-Way Digital: 18mm OD • PUR Jacket • Individual foil + Overall Braided Screen

Video Cables & Multicores

V06/28 ■ ■ ■ ■ ■ \$2.15

Install 75Ω Video Cable: 4.5mm OD • FRNC Jacket • Foil + Braided Shield

V06/37 ■ ■ ■ ■ ■ \$2.45

Install 75Ω Video Cable: 6.2mm OD • PVC Jacket • Braided Shield

V06/37DZ ■ \$3.75

TV Studio Videc Cable: Double Braided Shield • 6.3mm OD • PVC Jacket

V10/66DZ ■ \$5.65

Long Transmission Video Cable: 10mm OD • PVC Jacket • Double Braided Shield

VM5 ■ \$16.95

5-Way 75Ω Video Cable: 15mm OD • PVC Jacket • Foil + Braided Shield

V06/37DZ ■ \$3.75

5-Way 75Ω Video Multicore: 15mm OD • PVC Jacket • Foil + Braided Shield

Camera Cables

TRIAx8 ■ \$8.95

Triaxial Camera Cable: 8mm OD • PUR Jacket • Braided Screens

TRIAx11 ■ \$12.95

Triaxial Camera Cable: 11mm OD • PUR Jacket • Braided Screens

TRIAx14 ■ \$21.95

Triaxial Camera Cable: 14mm OD • PUR Jacket • Braided Screens

Triaxial Camera Cable: 14mm OD • PUR Jacket • Braided Screens

XLR To XLR Multicores



Smartlink

SL12/4EC20 \$1,395.00

12 Inputs/4 Returns • 20m Cable

SL16/4EC30 \$1,895.00

16 Inputs/4 Returns • 30m Cable

SL16/4EC50 \$2,295.00

16 Inputs/4 Returns • 50m Cable

SL24/4EC30 \$2,495.00

24 Inputs/4 Returns • 30m Cable

SL24/4EC50 \$3,195.00

24 Inputs/4 Returns • 50m Cable

Multicore Systems

Klotz ais offers two premium quality multicore solutions.

1. Klotz standard Modular Range using the components below: RackMount/ WallMount/ Floor Standing Stage Boxes (with optional Transformer Splits), MultiPin to MultiPin Multicores, PigTail Fan Adaptors and Studio Looms.

2. Klotz Custom Range puts the design in your hands! Type and size of multicores, connectors, multipins, stageboxes, splits etc.

Call for details.

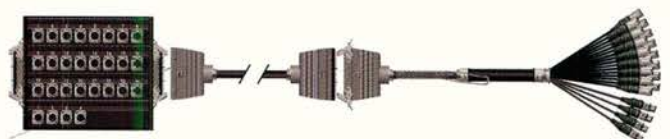
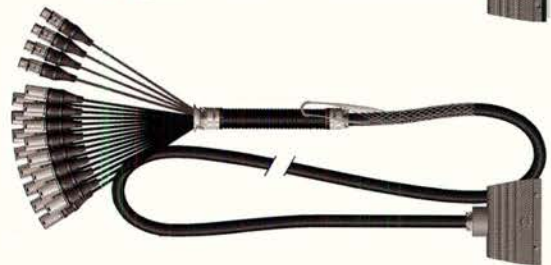
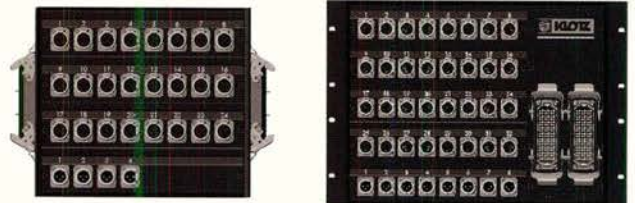

Audio & Video Switchers



CINDE 44 **\$1,695.00**
 4 IN/4 OUT VIDEO & STEREO AUDIO MATRIX SWITCHER: Full Matrixing Capabilities via Front Panel 'Click' Illuminated Keypad • Fully Electronic Switching • Data Input for Crestron/AMX Optional.

CINDE 44	VIDEO	AUDIO
FORMAT	PAL/NTSC/SECAM	-
MAXIMUM SIGNAL LEVEL	-	+4dBm
BANDWIDTH	>8MHz	5Hz TO 22kHz
DIFFERENTIAL GAIN ERROR	<0.1%	-
DIFFERENTIAL PHASE ERROR	<0.15%	-
THD	<0.01%	<0.1%
NOISE	-	<-72dB
INPUT IMPEDANCE	75 OHM	47 KOHM
OUTPUT IMPEDANCE	75 OHM	100 OHM
CONNECTORS	BNC	RCA

CINDE 82YC	VIDEO	AUDIO
FORMAT	PAL/NTSC/SECAM	-
MAXIMUM SIGNAL LEVEL	-	+4dBm
BANDWIDTH	>8MHz	5Hz TO 22kHz
DIFFERENTIAL GAIN ERROR	<0.1%	-
DIFFERENTIAL PHASE ERROR	<0.15%	-
THD	<0.01%	<0.1%
NOISE	-	<-72dB
INPUT IMPEDANCE	75 OHM	47 KOHM
OUTPUT IMPEDANCE	75 OHM	100 OHM
CONNECTORS	BNC	RCA



CINDE 82YC **\$1,895.00**
 8 IN/2 OUT VIDEO/YC/ STEREO AUDIO MATRIX SWITCHER: Full Matrixing Capabilities via Front Panel 'Click' Illuminated Keypad • Control Input for Crestron/AMX/Infra Red • 8x BNC+4x Y/C (S-VHS) Ins/2x BNC+1x Y/C Outs.



CINDE 88 **\$2,795.00**
 8 IN/8 Out VIDEO & STEREO AUDIO MATRIX SWITCHER: Full matrixing Capabilities via Front Panel 'Click' Illuminated Keypad • RS-232 Control Input • Audio Follows Video • LED Output Display • 8 Memory Configuration Presets.

CINDE 88 / 88YC	VIDEO	AUDIO
FORMAT	PAL/NTSC/SECAM	-
MAXIMUM SIGNAL LEVEL	-	+4dBm
BANDWIDTH	>8MHz	5Hz TO 22kHz
DIFFERENTIAL GAIN ERROR	<0.1%	-
DIFFERENTIAL PHASE ERROR	<0.15%	-
THD	<0.01%	<0.1%
NOISE	-	<-72dB
INPUT IMPEDANCE	75 OHM	47K OHM
OUTPUT IMPEDANCE	75 OHM	100 OHM
CONNECTORS	BNC	RCA

CINDE 88YC **\$3,595.00**
 As Cinde 88 above with Y/C S-VHS Capability on Mini-DIN In/Out.

CINDE 201Su	VIDEO	AUDIO
FORMAT	PAL/NTSC/SECAM	-
MAXIMUM SIGNAL LEVEL	-	+4dBm
BANDWIDTH	>8MHz	5Hz TO 22kHz
DIFFERENTIAL GAIN ERROR	<0.1%	-
DIFFERENTIAL PHASE ERROR	<0.15%	-
THD	<0.01%	<0.1%
NOISE	-	<-72dB
INPLT IMPEDANCE	75 OHM	47 KOHM
OUTPUT IMPEDANCE	75 OHM	100 OHM
CONNECTORS	RCA	RCA

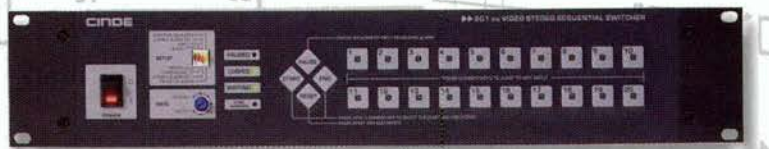

CINDE 201Su **\$1,895.00**
 20 IN/1 OUT VIDEO & STEREO AUDIO PROGRAMMABLE SEQUENTIAL SWITCHER: Front Panel Manual Source Selection Switches or Auto Sequential Sampling with Adjustable Rate & Selected Sources • Additional Units can be Looped Together • Drop-Out Alarm warns of Signal Loss.

Specialist Video Signal Isolator

CINDE 3IS	VIDEO	AUDIO
FORMAT	PAL/NTSC/SECAM	-
GAIN	1.0 TERMINATED	-
ISOLATION	1400V	-
BANDWIDTH (-3dB)	15MHz	-
DIFFERENTIAL GAIN ERROR	<0.2%	-
DIFFERENTIAL PHASE ERROR	<0.3%	-
THD	-	-
NOISE	-	-
INPUT IMPEDANCE	75 OHM	-
OUT/UT IMPEDANCE	75 OHM	-
CONNECTORS	BNC	-



CINDE 3IS **\$495.00**
 VIDEO OPTO ISOLATOR: The Problem solver • Isolates Input & Output Signals to 'Condition' Video Signal and Eliminate 50Hz Noise • Two Outputs • 215x110x44mm (LxWxH).

Audio & Video Selector

CINDE 8AVS **\$285.00**
 8 IN/1 OUT VIDEO & STEREO AUDIO SELECTOR: DC-8MHz Video/10Hz-22KHz Audio Bandwidth • Vertical Mount ABS Box with Mounting Lugs • 150x80x50mm (LxWxH)

Audio & Video Distribution Amplifiers

CINDE 2AVP \$255.00

1 IN/2 OUT VIDEO/STEREO AUDIO DISTRIBUTION AMPLIFIER: 1 Channel In (Video & Stereo Audio) to 2 Channels Out • ABS Box with Mounting Lugs • 150x80x50mm (LxWxH).



CINDE 2AVP	VIDEO	AUDIO
FORMAT	PAL/NTSC/SECAM	-
GAIN	1.0 TERMINATED	UNITY (47K _{LOAD})
MAXIMUM SIGNAL LEVEL	-	+10dBm
BANDWIDTH (-3dB)	50MHz	5Hz TO 22kHz
DIFFERENTIAL GAIN ERROR	<0.1%	-
DIFFERENTIAL PHASE ERROR	<0.15%	-
THD	<0.01%	<0.1%
NOISE	-	<-72dB
INPUT IMPEDANCE	75 OHM	47 KOHM
OUTPUT IMPEDANCE	75 OHM	100 OHM
CONNECTORS	RCA	RCA

CINDE 4VP \$255.00

1 IN/4 OUT VIDEO DISTRIBUTION AMPLIFIER: High Performance Video Amplifier • ABS Box with Mounting Lugs • 150x80x50mm (LxWxH).



CINDE 3VP \$295.00

1 IN/3 OUT VIDEO DISTRIBUTION AMPLIFIER: BNC In & Out High Performance Video Amplifier • ABS Box with Mounting Lugs • 150x80x50mm (LxWxH).

CINDE 4VP / 3VP	VIDEO	AUDIO
FORMAT	PAL/NTSC/SECAM	-
GAIN	1.0 TERMINATED	-
MAXIMUM SIGNAL LEVEL	-	-
BANDWIDTH (-3dB)	50MHz	-
DIFFERENTIAL GAIN ERROR	<0.1%	-
DIFFERENTIAL PHASE ERROR	<0.15%	-
THD	<0.01%	-
NOISE	-	-
INPUT IMPEDANCE	75 OHM	-
OUTPUT IMPEDANCE	75 OHM	-
CONNECTORS	RCA (4VP) BNC (3VP)	-

CINDE 4SP \$375.00

1 IN/4 OUT S-VHS DISTRIBUTION AMPLIFIER: 4-Pin Mini DIN Connector In & Out • ABS Box with Mounting Lugs • 150x80x50mm (LxWxH).



CINDE 4SP	VIDEO	AUDIO
FORMAT	PAL/NTSC/SECAM	-
GAIN	1.0 TERMINATED	-
MAXIMUM SIGNAL LEVEL	-	-
BANDWIDTH (-3dB)	50MHz	-
DIFFERENTIAL GAIN ERROR	<0.1%	-
DIFFERENTIAL PHASE ERROR	<0.15%	-
THD	<0.01%	-
NOISE	-	-
INPUT IMPEDANCE	75 OHM	-
OUTPUT IMPEDANCE	75 OHM	-
CONNECTORS	4-PIN MINI-DIN	-

CINDE 4AP \$255.00

1 IN/4 OUT AUDIO DISTRIBUTION AMPLIFIER: RCA In & Out • 22KHz Audio Bandwidth • ABS Box with Mounting Lugs • 150x80x50mm (LxWxH).



CINDE 4AP	VIDEO	AUDIO
FORMAT	-	UNITY (47K _{LOAD})
GAIN	-	+10dBm
MAXIMUM SIGNAL LEVEL	-	5Hz TO 22kHz
BANDWIDTH (-3dB)	-	-
DIFFERENTIAL GAIN ERROR	-	-
DIFFERENTIAL PHASE ERROR	-	-
THD	-	<0.1%
NOISE	-	<-72dB
INPUT IMPEDANCE	-	47 KOHM
OUTPUT IMPEDANCE	-	100 OHM
CONNECTORS	-	RCA

CINDE 8V \$475.00

1 IN/8 OUT VIDEO DISTRIBUTION AMPLIFIER: High Performance VDA • Signal & Power Status LED's • Cable Compensation (100/200/400+ Mtrs) • 215x95x44mm (LxWxH).



CINDE 8V	VIDEO	AUDIO
FORMAT	PAL/NTSC/SECAM	-
GAIN	1.0 TERMINATED	-
MAXIMUM SIGNAL LEVEL	-	-
BANDWIDTH (-3dB)	50MHz	-
DIFFERENTIAL GAIN ERROR	<0.3%	-
DIFFERENTIAL PHASE ERROR	<0.05%	-
THD	-	-
NOISE	-	-
INPUT IMPEDANCE	75 OHM	-
OUTPUT IMPEDANCE	75 OHM	-
CONNECTORS	BNC	-

CINDE 100AV \$1,045.00

1 IN/10 OUT VIDEO/STEREO AUDIO DISTRIBUTION AMPLIFIER: Rack mount • Professional VDA & ADA • High Signal Integrity & Stability • 1RU • Now with loop through facility.



CINDE 100AV	VIDEO	AUDIO
FORMAT	PAL/NTSC/SECAM	-
GAIN	1.0 TERMINATED	UNITY (47K _{LOAD})
MAXIMUM SIGNAL LEVEL	-	-
BANDWIDTH (-3dB)	50MHz	5Hz TO 35kHz
DIFFERENTIAL GAIN ERROR	<0.3%	-
DIFFERENTIAL PHASE ERROR	<0.05%	-
THD	<0.01%	<0.1%
NOISE	-	<-72dB
INPUT IMPEDANCE	75 OHM	47 KOHM
OUTPUT IMPEDANCE	75 OHM	100 OHM
CONNECTORS	BNC	RCA

Audio & Video Switchers

CINDE 4AVS \$425.00

4 IN/1 OUT VIDEO & STEREO AUDIO SWITCHER: The Smart Solution Box • Controllable Via D9 Port for AMX, Crestron or other Automated Control System • ABS Box with Mounting Lugs • 150x80x50mm (LxWxH).



CINDE 4AVS	VIDEO	AUDIO
FORMAT	PAL/NTSC/SECAM	-
GAIN	-	+4dBm
MAXIMUM SIGNAL LEVEL	-	5Hz TO 22kHz
BANDWIDTH (-3dB)	>8MHz	-
DIFFERENTIAL GAIN ERROR	<0.1%	-
DIFFERENTIAL PHASE ERROR	<0.15%	-
THD	<0.01%	<0.1%
NOISE	-	<-72dB
INPUT IMPEDANCE	75 OHM	47 KOHM
OUTPUT IMPEDANCE	75 OHM	100 OHM
CONNECTORS	RCA	RCA

EUPHONIX



MULTI • TRACK RECORDER

The revolutionary new R-1 Multi-Track Recorder offers the traditional feel of a reel-to-reel machine with the advantages of today's technology. Designed as a direct replacement for any type of multi-track machine or mag dubber the R-1 supports all standard formats up to the highest fidelity 24bit 96kHz.

Featuring transparent AD/DA converters and 40 bit internal floating point processors the R-1 offers superior sound quality, improved efficiency, upgradeability, extra reliability and still maintains the familiar Reel Feel™ of tape machines. From \$60,000.00



Euphonix is a leading supplier of computer controlled professional audio production systems for broadcast production, music recording, audio post for film & television and live theatre sound reinforcement.

The company manufactures two different professional audio mixing systems which are in use worldwide: the new System 5 digital console and the CS3000, a digitally controlled analog system. The R-1 is a digital multi-track recorder offering the benefits of digital recording with familiar controls and interface of a traditional reel-to-reel machine. A new range of high quality, multi-channel digital and analog converters provide the professional audio industry with a cost effective way to interface between the analog and digital worlds.



Euphonix

HIGH PERFORMANCE AUDIO SYSTEMS

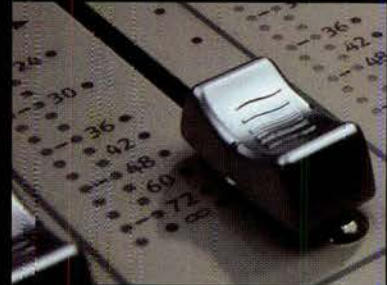

SYSTEM 5

DIGITAL

The world's first future-proof large format 96kHz fully digital console. As a stand alone console or as a hub sharing processing power among a series of control surfaces the S5 provides all the power you'll need: LGRS, 5.1 and 7.1 formats, dedicated dynamics, EQ, filters and pan channel processing, flexible bus configurations of up to 48 groups, 48 mix, 24 aux and 22 monitor buses and, of course, instant configurations recall. POA

Premium Quality Analogue Equalisers

EQ231S **\$2,295.00**

GRAPHIC EQUALISER/DUAL CHANNEL 31-BAND: Centre Detented Short Throw Faders and 'Venue Humidity' Control (a single fader which compensates for HF Variations in Venue Humidity during a Show). High Pass Filters • Balanced Ins and Outs • 2RU.

EQ231-GSP **\$3,495.00**

GRAPHIC EQUALISER/DUAL CH. 31-BAND 'WORKSTATION': Premium Long Throw Faders • Dual Variable Freq Shelving EQ • Variable Low & High Pass Filters • Limiter Gate • Bypass Switches • Fast RMS Detector and dbx Soft-Knee Compressor • Channel Phase Reversal • 3RU.

231G-TX **\$345.00**

OUTPUT TRANSFORMER OPTION FOR EQ231-G & EQ231-GSP (2 CHANNELS).

231G-Coil **\$745.00**

COIL OPTION (4kHz-20kHz) FOR EQ231-G & EQ231-GSP (2 CHANNELS).

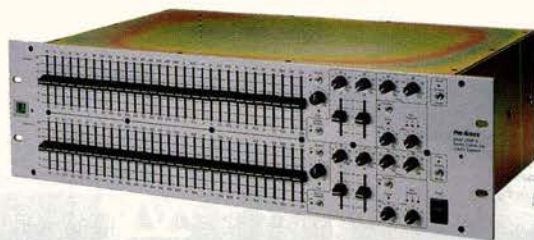

Instant Access Equalisation: LA Digital

DIG-EQ **\$5,995.00**

PROGRAMMABLE DIGITAL EQ/DYNAMICS PROCESSOR: 2-Ch • 31-Band EQ • Parametric • Hi-Lo Filters • Shelving EQ • Compressor/Limiter and Expander/Gate • Instant Access to all Functions • Midi, RS232 and RS422 Control • Large Backlit LCD • Digital In/Out • 2RU.

DIG-EQS **\$3,995.00**

PROGRAMMABLE DIGITAL EQUALISER/DYNAMICS PROCESSOR: Slave Unit to DIG-EQ • One DIG-EQ can control upto 15 DIG-EQS Dual Channel Slave units • 1RU.

DIG-REMOTE **\$5,495.00**

REMOTE CONTROL: Accesses all Dig-EQ functions for both Master Units and Slaves. Includes Dig-EQ Front Panel complete with LCD Screen. Wired or Wireless Options.

DIG-RTA **\$2,195.00**

REAL TIME ANALYSER OPTION

DIG-DD **\$745.00**

DELAY OPTION: Provides up to 1.0 Second of Delay in Millisecond Increments

D·I·G·E·Q



LA is changing.....

PS10



PS10 **\$1,795.00**
 PRO MONO RECORDING CHANNEL: Very Low Noise Pre-amp • Variable Threshold Expander • Noise Reduction • De-Esser • Soft/Hard Knee Fully Adjustable Compressor • 4-Band EQ with Hi & Lo Shelving & Fully Parametric Mids • Bal XLR and Unbal TRS In/Out • 1RU.

SPX20



SPX20 **\$1,295.00**
 12-2 STEREO SOURCE SELECTOR/PRE AMP/MIXER: 6 Stereo Inputs with Bal XLR & Unbal TRS • Level Trim & Button Selection to 2 Ch L/R Outs • PLU: Record Out and Headphone Amp with Level • 1RU.

TCX20



TCX20 **\$1,295.00**
 DUAL TUBE COMPRESSOR: 2 Ch of Solid-State Gain with In & Out Valve Amplification • Variable Threshold/Ratio and Auto Attack/Release • Gain Make-up • Stereo Link • Balanced XLR & Unbal TRS In/Out • 1RU.

GCX20



GCX20 **\$895.00**
 DUAL AUTO COMPRESSOR/NOISE GATE: 2 Ch Compressor with Variable Threshold/Ratio and Dual Mode Auto Attack/Release • Gain Make-up & Gain Reduction Metering • Expander/Gate with Variable Threshold/Release • Stereo Link • Balanced XLR & Unbal TRS In/Out • 1RU.

MPX10



MPX10 **\$1,095.00**
 MONO MULTI PROCESSOR: Low Noise Mic/Line Pre amp with a FET In/Out • Noise Reduction • Variable Threshold/Ratio Auto Compressor/De-Esser • 4-Band EQ with Sweepable Hi & Lo Shelving EQ & Fully Parametric Mids • Bal XLR and Unbal TRS In/Out • 1RU.

MLX20



MLX20 **\$895.00**
 DUAL MIC/LINE PRE AMP WITH DI: Low Noise Dual Mic/Line Pre amp with a FET Based DI Input • +48v Phantom Power • Phase Reverse • Sweepable HP Filter • Input/Output Gain • Bal XLR and Unbal TRS In/Out • 1RU.

EQX20



EQX20 **\$895.00**
 DUAL 3 BAND/MONO 6 BAND PARAMETRIC: 2 Ch Overlapping 3 Band EQ or 1 Ch 6 Band EQ • All Bands are Fully Parametric with a 75Hz HP Filter for each Channel • Bal XLR and Unbal TRS In/Out • 1RU.

Microphone/Media Splitters

MS824M

MS824M **\$5,995.00**
 ACTIVE MICROPHONE SPLITTER: 8 CHANNELS: 1 IN/4 OUT: TRX Bal XLR Ins to TRX Buffered XLR Floating Outs • 20dB Pad and Phantom Power on Ins • Master Test Module allows Simultaneous Monitoring via Headphone or LED Barograph of any Channel Input Signal • 4FU.

MS824

MS824 **\$5,495.00**
 ACTIVE MICROPHONE SPLITTER: Slave Module to 824M. As 824M but without Master Test Module • One 824M required for each system • Additional 8 Ch. Modules in System utilise Test Facilities in 324M • 4RU.

MS824R

As MS824 but with Bypass Relay. Links Outputs if Power Fails.

MS824RX

As MS824 but with Optional Bypass Relay and Passive Splitter Transformer. Passively Splits and Transformer Balances Master Output if Power Fails.

MS824PS

MS824 POWER SUPPLY UNIT: Powers up to Four 824/824M's or Two 824R/824RX's • 2RU.

MS424

MS424 **\$2,495.00**
 ACTIVE MICROPHONE SPLITTER/4 CHANNELS: 1 IN/4 OUT: Also Configurable as 1 In/8, 12 or 16 Out, or 2 In/8 Out • Electronically Balanced XLR Ins to XLR TRX Buffered Floating Outs • 20dB Pad and Phantom Power on Inputs • Internal PSU • 1RU.

424X

Input Transformer Option for 424 (4 Transformers)

\$795.00

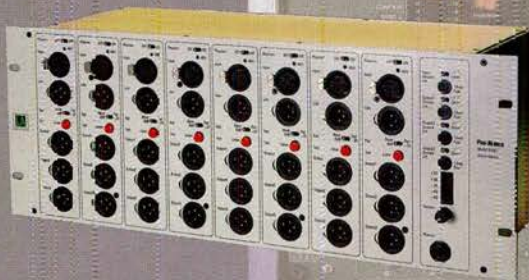

UT LEFT

World Renown Problem Solving Tool Box Range

UB285A



SBT **\$295.00**
ONE CHANNEL PASSIVE TRANSFORMER BALANCING BOX: XLR In and Out for Balancing Unbalanced lines • Ground Lift Switch for resolving Earth Loops • Broadcast Quality Transformers As DBT but Single Channel.

UB285B



DBT Mk3 **\$445.00**
TWO CHANNEL PASSIVE TRANSFORMER BALANCING BOX: As SBT but Dual Channel.

UB285C



TBOX **\$225.00**
CABLE TESTER: For testing Short and Open Circuits and Crossed Wiring in XLR, 1/4" Jack, Midi and RCA Cables • Diagnosis is displayed by three Tri-Colour LED's with Diagnosis Table printed on rear of unit • Fuse checking Facility • Switchless.

UB285D



CB3 **\$165.00**
CANBOX: 1 In 3 Out Headphone Distribution Box. Accommodates Headphones of Different Impedance on same Circuit and can be Linked Together to run up to 25 x 8Ω or 150 x 600Ω Headphone.

Super Clean Direct Injection Devices



DI2 Mk3 **\$325.00**
DI BOX ACTIVE TRANSFORMERLESS: Auto Switching from 2 x 9v Battery to Phantom Power when available • Four Position/Two Button Pad giving Total of 40dB Range • Ground Lift • Balanced and Unbalanced Output and Link Facility.



DIX **\$215.00**
PASSIVE DI BOX: With High Quality Wide Band Silicon-Iron Core Transformer • Normal/High Level Input Switch • Ground Lift • Balanced Out and Link Facility.



SC3 **\$325.00**
THREE WAY MIC SPLITTER COMBINER: Passive 1 In/3 Out Mic Splitter or 3 In/1 Out Mic Combiner • Featuring High Quality Transformer for Excellent Frequency Response and Minimum Distortion • XLR Ins and Outs.



DIP Mk3 **\$345.00**
SHIELDED PASSIVE DI BOX: With Shielded Mu Metal Transformer • Normal/High Level Input Switch • Ground Lift • Balanced Output and Link Facility.



MDB **\$1,895.00**
DI BOX 8 CHANNEL RACK MOUNT: Eight Channels of DI2 Mk3 • Mains Powered • 2RU



PHP **\$695.00**
PHANTOM POWER SUPPLY UNIT: 48v 4-Channel Mains Powered • XLR's In and Out • Die Cast Metal Box.



PC80 MKII **\$895.00**
PHASE TESTER: World Standard 2-Box (Generator and Receiver) System for measuring Phase in individual components or through out an Audio System (Amps, Speakers, Mics, Patch Bays etc etc) • The PC80 MkII Measures both Acoustically and Electronically.

Compressor Limiters

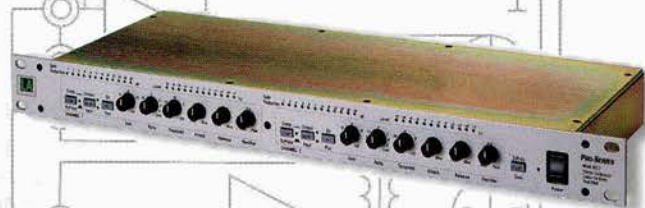

BCL2 **\$1,995.00**
COMPRESSOR LIMITER: Two Channel with Link Switch for Stereo Signal • Variable Threshold, Gain, Attack and Release and Compression Ratio • Input/Output and Compressed Signal Level LED Bargraphs • De-esser • TRX Bal Outs • Excellent RFI Rejection • 1RU.



FGC2 **\$2,495.00**
DUAL SPLIT BAND COMPRESSOR/FREQUENCY SELECTIVE GATE: Dual Compressor with Variable Threshold, Ratio, Release & Slow/Fast Attack • Dual Noise Gate with Variable Threshold, Range, Release & Auto/Fast Attack • Stereo Link • Frequency Splitting Filter (Sidechain/Audio Path) • 1RU.

Media Splitter/DA

DA82 **\$1,295.00**
LINE LEVEL MEDIA SPLITTER/AUDIO DISTRIBUTION AMPLIFIER: Configurable for Mono (1x8) or Stereo (2x4) • Input and Output level adjustment via Calibrated/Un calibrated Switching • All Inputs and Outputs are Electronically Balanced on XLR's • 1RU.



UT RIGHT

UB285A

UB285B

UNIVERSAL BUFFER SYSTEM



For Interfacing, Balancing, Linking, Splitting Amplifying, Testing, Routing, Buffering, Monitoring, Distributing, Remote Controlling, Tackling, Passing, Dribbling, Shooting.



UB-Special Function Modules



UB282
MIC PEE AMP MODULE: Transformer Balanced In and Out with Front Panel In and Out Trim Pots.

\$465.00

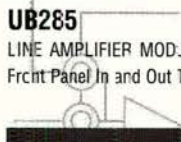

UB285
LINE AMPLIFIER MODULE: Electronically Balanced In/TrX Bal Out • Front Panel In and Out Trim Pots

\$345.00



UB285T
LINE AMPLIFIER MODULE: Transformer Balanced In and Out • Front Panel In and Out Trim Pots.

\$425.00



UB289
DUAL OUTPUT MIC/LINE MIXER MODULE: Two Input Mixing/Summing Stage and two Transformer Balanced Outputs with overall Trim • Rear duplicate Inputs can be Daisy-Chained • 40dB Internal Fader.

\$425.00



UB293
DUAL OUTPUT MODULE: Two Transformer Balanced Outputs with Individual Trim • Rear duplicate Inputs can be Daisy-Chained.

\$425.00

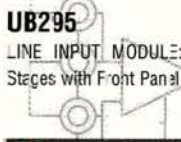

UB295
LINE INPUT MODULE: Two Electronically Balanced Line Input Stages with Front Panel Trim Pots.

\$295.00



UB295T
LINE INPUT MODULE: Two Transformer Balanced Line Input Stages with Front Panel Trim Pots.

\$495.00



UB297
VIDEO DISTRIBUTION MODULE: 1 In/4 Out Video Dis Amp with BNC Link for Daisy-Chaining.

\$465.00



UB302
AUDIO DISTRIBUTION MODULE: One Electronically Balanced In/4 Unbalanced RCA Outs • Daisy-Chain Facility.

\$255.00



UB302TA
AUDIO DISTRIBUTION MODULE: As UB302 but with Transformer Balancing.

\$425.00

Frames

UBF8 **\$895.00**

UB POWERED MAINFRAME/8 MODULE: Universal Buffer Main Powered Frame for Eight UB Modules • Module linking is via rear RCA Ins and Outs • Standard Rackmount included • 2RU.

UBRML **\$95.00**

Optional Rack Mount Ears to Recess UBF8 100mm within Equipment Rack to facilitate Front Panel Connectors

UBF4 **\$695.00**

UB POWERED MAINFRAME/4 MODULE: Rackmount • 1RU

UBF2 **\$445.00**

UB POWERED MAINFRAME/2 MODULE: Rackmount NOT included • 1RU (Half Rack Width).

UBRM2 **\$75.00**

Rackmount Kit for UBF2

UB BLANK **\$25.00**

UB Blank Panel



UB286 **\$465.00**
OSCILLATOR MODULE: Delivers Low Distortion Sine Waves at 1 or 10kHz • Unbalanced and Transformer Balanced Output with Front Panel Trim Pot.

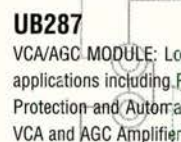

UB287 **\$465.00**
VCA/AGC MODULE: Low Distortion VCA and Level-Detector for applications including Remote Control of Audio Signals, Speaker Protection and Automatic Volume Control • Switchable between VCA and AGC Amplifier Modes.

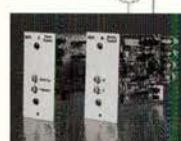

UB290 **\$425.00**
EQUALIZER MODULE: Voltage-Controlled Shelving EQ offering up to 18dB Cut or Boost at 60kHz and 15dB Cut or Boost at 12kHz.

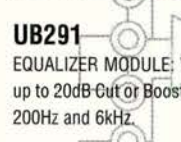

UB291 **\$425.00**
EQUALIZER MODULE: Voltage-Controlled Sweepable EQ offering up to 20dB Cut or Boost at a Centre Frequency adjustable between 200Hz and 6kHz.



UB292 **\$255.00**
STEREO HEADPHONE AMP MODULE: For Headphones from 8Ω to 600Ω.

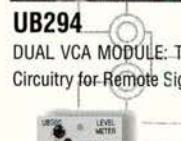

UB294 **\$425.00**
DUAL VCA MODULE: Two low distortion VCA's and Control Circuitry for Remote Signal Control Applications via 10K Pot.

UB300 **\$425.00**

DUAL LEVEL METER MODULE: Visual Monitor of two signals via 10 Segment 3-colour LED Bargraphs with Selectable Peak or VU Ballistics.



UB300P **\$295.00**
VOLUME CONTROL AND LEVEL METER MODULE: 10 Segment Three-Colour LED Bargraphs with Volume Control which can be patched into any Signal Path.



UB301 **\$375.00**
VOICE-OVER/AUTOMATIC SOURCE TRIGGER MODULE: Program Detector using the presence or absence of a signal to attenuate another program and/or trigger a replacement source.

15 * MONO OUTPUTS



Rack Mount CD Players

PMD330

PROFESSIONAL CD PLAYER: Large backlit LCD Display • Single/Continuous/Programmable Play Modes • Digital +/- 12% Pitch Controls • Serial Port • Fader Start • Backlit Transport Buttons • 10 Button Key Pad for Direct Track and Index Access • Programmable Cue Point Memory • Headphone with Level • End of Track Monitor • A-B Repeat • 30° from Horizontal Operating Angle • Reads CD-R and CD-RW as well as standard CD audio • 2RU.

PMD331

BROADCAST TYPE CD PLAYER: As PMD330 plus XLR Balanced Outputs • 10 sec Anti-Shock Memory Buffer (For Uninterrupted Program) • Dual Function Jog Wheel • Pitch Bend • Instant Start from RAM Buffer • 25-Pin Parallel Port and XLR Digital Out.

PMD340

BROADCAST TYPE CD PLAYER: As PMD340 but with Industrial Standard VAM 1250 Mechanism for Intense Disc Access Operations and Constant Usage.



CD Recorder: CDR & CD-RW

CDR630

\$2,195.00

CD/CD-RW RECORDER: Recording CDR & CD-RW on audio & data discs • XLR Analogue In/Out • AES/EBU • SPDIF • Sample Rate Converter • Digital Audio Delay & Auto Indexing from CD, DAT, DCC, MD • High Speed Copying Facility • IR Remote • 2RU.

CDR640

\$3,995.00

CD/CD-RW RECORDER: Fully optioned Mastering CDR. As CDR630 plus: Erase TOC, Track and Disc on RW Discs • DSP based data management to manipulate incoming track ID's with frame accuracy • One touch instant sync recording • Variable audio delay (0-4secs) • Adjustable Auto Track Increment Threshold (-10 to -70dB) • Full SCMS copy bit manipulation • Selectable emphasis bit setting • Source Dependent Auto Recording Stop • Preset Functions • Balanced XLR Analogue In/Out • AES/EBU and SPDIF In/Out • Parallel D-Sub remote control port • 2RU.



\$1,095.00

\$1,495.00

\$1,795.00

PMD321

\$895.00

BROADCAST TYPE SINGLE CD PLAYER: Balanced XLR Outputs • Fader Start • Auto Cue • Exceptional Shock Isolation • Single Bit D/A Converters • 18-Bit Digital Filtering • +/- 8% Pitch Control • Digital Out • Various Programming Functions • 2RU.

Portable Minidisc Recorder

PMD650

\$2,995.00

STEREO MINIDISC PORTABLE RECORDER: Recording Time of 148min Mono/74 min Stereo • Built-in clock • Data Back-up with TOC Data, Time & Date • 20 Sec Shock Proof Buffer Memory • Auto End Search and Dual Level Mono Recording (as set & -15dB) • Recording Time of 148min Mono/74 min Stereo • XLR Mic/Line In • Digital In (RCA) SPDIF • Digital Out (XLR) • +48v Phantom • Ambient Noise Control • External Speaker Out (200x170x50mm) • 1.2Kg



Portable Flash RAM/Hard Disk Recorder

PMD680/690 are digital recorders using either flash RAM or Hard Disk cards with PCMCIA III ATA interface. Cards can be interchanged like audio cassette but information is instant access. Recordings can be edited, cut, pasted, added to, sped or slowed, and then saved to the same card. Audio data is stored in MPEG-1 layer 2 or in Linear PCM format using 48kHz sampling frequency. Files are written in Broadcast Wave Format for editing by PC. Three different bit rates offer the optimum balance between storage efficiency and sound quality.



PMD680

\$2,995.00

MONO FLASH RAM/HARD DISK RECORDER: Pitch Control • SPDIF (Phono) In/Out • (200x170x50mm) • 1.2Kg

PMD690

\$TBA

STEREO FLASH RAM/HARD DISK RECORDER: Parallel Port • Pitch Control • SPDIF (Phono) In/Out • (200x170x50mm) • 1.2Kg



Portable Cassette Recorders

PMD101 **\$645.00**

MONO 2-HEAD PORTABLE CASSETTE: Built-in Condenser Mic • 6.5mm Jack Mic Input • RCA Line Out • Two Speed Recording • Auto Level Control • +/-20% Pitch Control • Tone Control and Half Speed Playback • Optional Carry Case • Plug Pack Included • 1.2Kg.

PMD222 **\$995.00**

MONO 3-HEAD PORTABLE CASSETTE: Includes features of PMD101 plus XLR Mic In • Peak Indicator • Memory Re-Wind • Optional Carry Case • Shoulder Strap/Plug Pack Included • 1.3Kg

CP430 **\$1,495.00**

STEREO 3-HEAD PORTABLE CASSETTE: Twin VU Meters • Two 6.5mm Jack Mic Input • RCA Line Out • Dolby B • dbx and MPX Noise Reduction • +/-6% Pitch Control • Memory Rewind • Carry Case/Shoulder Strap/Plug Pack Included • 1.3Kg.

RB430 **\$185.00**

NI-CAD RE-CHARGEABLE BATTERY PACK: Suitable for all models • Recharges automatically within the Cassette Recorder.

CLC221 **\$75.00**

CARRY CASE (VINYL): For PMD101 & 222.

MP-PP **\$45.00**

PLUG PACK: (One Included).



Rack Mount Cassette Players



PMD501 **\$695.00**

SINGLE CASSETTE PLAYER: Two Head • Optical Auto Reverse • Dolby B • Switchable MPX Filter • Headphone Jack with Volume Control • RCA Line Input • RC5 Remote Interface • 3RU.

PMD502 **\$895.00**

SINGLE CASSETTE PLAYER: Two Head • Optical Auto Reverse • +/-15% Pitch Control • Front Panel Mic Input • Variable Output • Dolby B/C • HX PRO • Real Time Counter • 3RU.

PMD502B **\$1,095.00**

BALANCED SINGLE CASSETTE PLAYER: As PMD502 with XLR Balanced Ins/Outs.

PMD510 **\$1,395.00**

DUAL TRANSPORT HEAVY DUTY CASSETTE DECK: Two Entirely Independent Decks • Auto Reverse • +/-10% Pitch Control • Dolby B/C • HX PRO • Linear Time Counter • Peak Hold Meters • High Speed Dubbing • Serial and Cascade Recording • 3RU.

PMD510B **\$1,595.00**

BALANCED DUAL TRANSPORT CASSETTE PLAYER: As PMD510 with XLR Bal. Outs.

PMD511 **\$1,895.00**

DUAL TRANSPORT HEAVY DUTY CASSETTE DECK: As PMD510 plus Stereo Mic Inputs and Mixing facility to mix Mic and Line Inputs to either or both Decks • 25-Pin GPI • ALC • 3RU.

PMD520 **\$1,995.00**

3-HEAD DUAL TRANSPORT HEAVY DUTY CASSETTE DECK: Two Entirely Independent Decks with Direct Tape Insertion/Removal • Removable Tape Mechanism • Auto Reverse (3 Min Overlap) • Simultaneous Recording • Loop-Through Output for Duplication • Dolby B/C • HX PRO • Record Balance • +/-3% Speed Control • RC-5 Remote Port (AMX & Crestron Compatible) • Time Counter • Peak Hold Meters • High Speed Recording • 3RU.

PMD520B **\$2,295.00**

BALANCED DUAL TRANSPORT CASSETTE PLAYER: As PMD520 with XLR Bal. Outs.

Combined CD/Cassette Player



PMD350 **\$1,495.00**

COMBINED CD/CASSETTE: Cassette: Auto Reverse • +/-15% Pitch Control • Variable Output • Dolby B/C • HX PRO • Fader Start • etc. etc. CD: Single or Continuous Play • +/-12% Pitch Control • Auto Cue • Digital Out • Fader Start • etc. etc. Triple Outs • 3RU.

PMD350B **\$1,895.00**

BALANCED COMBINED CD/CASSETTE: As PMD350 with XLR Balanced Outs.

Remote Control Kits

RC5PMD **\$295.00**

REMOTE CONTROL KIT (FOR PMD510/520): Consisting of IR Handset Controller and IR Receiver Eye with 1RU Mounting Panel and Wall Mount Blank.

RC5PMDSW **\$295.00**

REMOTE CONTROL KIT (FOR PMD320/321/350/501/502): Consisting of IR Handset Controller and IR Receiver Eye with 1RU Mounting Panel and Wall Mount Blank.

WRC200 **\$545.00**

WIRED REMOTE CONTROL KIT (PMD320/321/350/501/502/510/520): Rugged Table Top Wired Remote Control • 16 Coloured Buttons control all CD & Cassette Functions Including Multiple Machines Simultaneously • 9V DC or Battery Powered.

Martin Audio

Martin Audio's new generation Concert Sound System, Wavefront 8, is a flexible platform capable of short, mid and long throw, any music genre, arrayable, stackable, flyable, this system is equal to the task.



W8 \$10,595.00

MID/HIGH TRAPEZOIDAL CABINET: 3 or 2-Way Active • Double 12" Low Mid, 6.5" with Toroidal Phase Plug High Mid and 1" HF • all Horn Loaded • 120Hz-18kHz • 135dB Peak SPL • 55° x 30° Dispersion • Fully Equipped for Flying • 80Kg • GREY.

W8S \$8,995.00

HYBRID SUB BASS TRAPEZOIDAL CABINET: Matching Dimensions to W8F • 18" Front Loaded and 15" Horn Loaded • 40-150Hz • 137dB Peak SPL • Fully Equipped for Flying • Wheel Mounted • 82Kg • GREY.

W8C \$8,695.00

MID/HIGH TRAPEZOIDAL CABINET: Same components and design as W8F but with one 12" low mid • 71Kg • GREY.

W8CS \$6,695.00

SUB BASS TRAPEZOIDAL CABINET: Flying Sub for W8C Concert Arrays • Port-Assisted Folded Horn single 800w 15" Driver • 40-200Hz • 138dB Peak SPL • MAN Equipped for Flying • Wheel Mounted • Same Dimensions as W8C • 66Kg • GREY.

WSX \$6,595.00

MONSTER SUB-WOOFER: Single Long Excursion 18" Driver on a 7' Folded Horn • Super Efficient 105dB/1w/m • Designed for Ground Stacking • Maximum impact in a block of 4 with horn mouths coupled • 96Kg • GREY.

W8CT \$13,495.00

DEDICATED LONG THROW HIGH CABINET: For Outdoor or Stadium use in a W8C Array • 3 x 6.5" High Mid & 6 x 1" HF Drivers • 750Hz-18kHz • 147dB Peak SPL • MAN Equipped for Flying • Wheel Mounted • Dimensions as W8C • 121Kg • GREY.

W8CM \$7,995.00

DEDICATED LONG THROW MID CABINET: For Outdoor or Stadium use in a W8C Array • 2 x 12" Low Mid Drivers • 120-750Hz • 142dB Peak SPL • MAN Equipped for Flying • Wheel Mounted • Dimensions as W8C • 78Kg • GREY.

MX5 \$3,695.00

W8 SYSTEM MONO CONTROLLER: Provides Crossover, Output Level, Phase Adjustment and Equalisation functions for 3 or 4-Way W8 Configuration • Exchangeable Cards for use with W8F, W8C, W8S and WSX • Two Required for Stereo System • 1RU.

DX1 \$5,495.00

DIGITAL CONTROLLER: Compact, Powerful DSP Based Audio Processing Unit • 2 Inputs & 6 Outputs • Configurable in 5 Basic Modes (3x2 way, 2x3 way, 4 way, 5way & 6 way) • Adjustable Gain & Delay • HF & LF Filters • 5 Bands of PEQ • Limiters, Delays & Polarity Controls • 1RU.

W A V E

Wavefront
Longthrow™

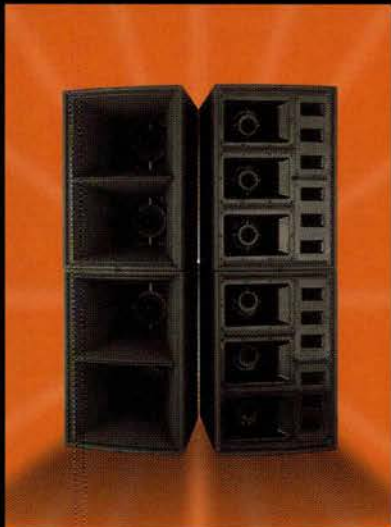

Blackline

Breaking The Sound Barrier: Flexibility, Performance and Price



BlackLine packs Martin Audio's many years of touring concert system design into an all new range of portable club speakers and brings legendary Martin Audio performance within the reach of musicians and DJ's on the club, cabaret and live circuits.

F12 \$2,095.00

FULL RANGE 12" 2-WAY PASSIVE SPEAKER: Dual Use FOH/Foldback Speaker • Rotatable CD Horn and Wedge Angle for Foldback • Tripod Mount • 65Hz-18kHz • 300w AES Power Handling • 8Ω • 80°x50° Dispersion • 97dB Sensitivity • 126dB Peak • Speaker Inputs • 10xM8 Hanging Inserts • Laminate Birch Ply • 571x400x364 (HxWxD) • 21Kg • BLACK.

F15 \$2,795.00

FULL RANGE 15" 2-WAY PASSIVE SPEAKER: As F12 with 15" LF and 1.4" HF Drivers • 690x470x443 (HxWxD) • 32.5Kg • BLACK.

S15 \$2,495.00

SINGLE 15" SUB-BASS SPEAKER: Front Loaded Vented System • 45Hz-120Hz • 500w AES Power Handling • 8Ω • 98dB Sensitivity • 129dB Peak • Speaker Inputs • Top Hat Fitting • Laminate Birch Ply • 690x470x496 (HxWxD) • 38.5Kg • BLACK.

S18 \$2,995.00

SINGLE 18" SUB-BASS SPEAKER: Front Loaded Vented System • 40Hz-120Hz • 500w AES Power Handling • 8Ω • 99dB Sensitivity • 130dB Peak • Speaker Inputs • Top Hat Fitting • Laminate Birch Ply • 690x561x595 (HxWxD) • 45Kg • BLACK.

S218 \$5,495.00

DOUBLE 18" SUB-BASS SPEAKER: Front Loaded Vented System • 35Hz-150Hz • 1000w AES Power Handling • 4Ω • 102dB Sensitivity • 136dB Peak • Speaker Inputs • Wheel Mounted • Laminate Birch Ply • 1066x561x780 (HxWxD) • 87Kg • BLACK.

H2 \$3,695.00

MID/HIGH 2-WAY SPEAKER: Horn-Loaded Switchable Active/Passive Mid/High • 150Hz-18kHz • 300w AES • 8Ω • 70°x40° Dispersion • 104dB Sensitivity • 133dB Peak • Speaker Inputs • 12xM8 Hanging Inserts • Laminate Birch Ply • 571x561x496 (HxWxD) • 35Kg • BLACK.

H3 \$6,595.00

FULL RANGE 15 3-WAY BIAMPED SPEAKER: Fully Horn-Loaded Components ensures Maximum Efficiency and Output • Passive Crossover on Mids & Highs • 50Hz-18kHz • 500w(LF)+300w(MF/HF) AES Power Handling • 8Ω • 70°x40° Dispersion • 104dB Sensitivity • 136dB Peak • Speaker Inputs • 12xM10 Hanging Inserts • Laminate Birch Ply • 1066x561x780 (HxWxD) • 77.5Kg • BLACK.

M3 \$1,195.00

SYSTEM CONTROLLER: Dedicated BlackLine Controller providing Active Crossover • EQ and Limiter Functions for H3 as well as various Sub-Bass Systems • 1RU.



F R O N T S E R I E S

W0.5 \$1,495.00

8" 2-WAY PASSIVE TRAPEZOIDAL CABINET: 8" Mid/Bass and 1" Compression Driver HF on Wooden Horn Flare • 70Hz-18kHz • 120dB Peak SPL • 8Ω • 70° x 50° Dispersion • Pole Mount and Omnimount Inserts • 10Kg • GREY.

W1 \$2,495.00

10" PASSIVE 2-WAY TRAPEZOIDAL CABINET: 10" Mid/Bass and 1" HF on Wooden Horn Flare • 75Hz-18kHz • 124dB Peak SPL • 8Ω • 70° x 40° Dispersion • Pole Mount and M8 Inserts • 14.5Kg • GREY.

W2 \$3,995.00

12" PASSIVE 2-WAY TRAPEZOIDAL CABINET: 12" Mid/Bass and 1" Compression Driver • 60Hz-18kHz • 128dB Peak SPL • 8Ω • 70° x 40° Dispersion • 10 x M8 Flying Inserts and Pole Mount • 24Kg • GREY.

W3 \$5,795.00

15" 3-WAY ACTIVE/PASSIVE TRAPEZOIDAL CABINET: 15" Bass • 6.5" Mid and 1" HF • Mid and HF with Passive Crossover • 55Hz-18kHz • 131dB Peak SPL • 8Ω Bass/16Ω Mid/HF • 65° x 40° Dispersion • Pole Mount and 12 x M8 Flying Inserts • 32Kg • Requires WX3 Controller • GREY.

W3P \$6,495.00

15" 3-WAY PASSIVE TRAPEZOIDAL CABINET: All Passive Version of W3.

W3T \$6,295.00

15" 3-WAY ALL ACTIVE TRAPEZOIDAL CABINET: As W3 but 3-way Active and Theatre spec • Black.

WS2A \$4,495.00

DOUBLE 15" SUB-WOOFER: Direct Radiating Floor Standing Sub for use with W3 or other system • 38 - 120Hz • 132dB Peak • 4Ω • 60Kg • Wheel Mounted • Designed for use with WX3S which provides System Limiters and Equalisation • GREY.

WX3A \$2,795.00

STEREO 2-WAY SYSTEM CONTROLLER: Dedicated W3 Series Controller providing System Limiting • Equalisation and Crossover Functions • 1RU.

IMPORTANT NOTE: Speakers are priced EACH - NOT PAIRS



C115



C115



C516



C516

Stage Wedge Monitors

Martin Audio's LE Series Stage Monitors are more commonly rider specified than any others. The LE350 and 700 feature Martin's differential dispersion horn technology which defines a constant sound pressure level over a large area allowing the artist considerable movement on stage without feedback or loss of information.

WM0.5

MINIATURE STAGE WEDGE MONITOR: 8" Mid/Bass and 1" HF on Wooden Horn Flare • 70Hz-18kHz • 120dB Peak SPL • 8Ω • 70° x 50° Dispersion • M8 Inserts • 9Kg • GREY.



\$1,495.00



LE350A

12" 2-WAY PASSIVE STAGE MONITOR: Ultra Compact Low Profile Broadcast Style Floor Monitor with 12" Bass and 1" Exit Compression Driver • 50°-100° Horizontal x 70° Vertical Dispersion • 70Hz-18kHz • 125dB Peak SPL • 8Ω • 23Kg • BLACK.

\$3,495.00

LE400C

15" 2-WAY ACTIVE/PASSIVE STAGE MONITOR: 15" Bass and 1" Exit Compression Driver • 40° Horizontal x 70° Vertical Dispersion • 50Hz-16kHz • 127dB Peak SPL • 8Ω • 32Kg • BLACK.

\$4,195.00

LE700A

15" 2-WAY ACTIVE STAGE MONITOR: 15" Bass and 1.4" Exit Compression Driver • 50°-100° Horizontal x 70° Vertical Dispersion • 60Hz-15kHz • 131dB/HF 129dB/LF Peak SPL • 8Ω/LF 16Ω/HF • 44Kg • BLACK.

\$5,295.00

MX5

SYSTEM CONTROLLER: 2-Channels of Crossover, Output Level, Phase Adjustment and Equalisation for Active Monitors • Exchangeable Cards for LE400 or 700 • 1RU.

\$3,695.00

ICT Based Contractor Speakers

Martin Audio's ICT principle lends itself ideally to the demands of commercial installation speakers. Compact, high powered, 2-way without a passive network, indestructible HF and high quality sound output with excellent speech definition. Contractor Friendly: Simple and reliable.

Conventional Wall Mounting Type

C115G/C115W

SURFACE MOUNT INSTALLATION SPEAKER: Designed to Impress Architects & Designers • Single 5" Mid/Bass & 1" ICT HF • 80Hz-20kHz • 50w AES • 8Ω • 90° x 90° Dispersion • 88dB Sensitivity • Binding Post • Bracket Supplied • 218x195x120 (HxWxD) • 1.7Kg • Available in GRAPHITE or LIGHT GREY.

\$285.00

C115G-T/C115W-T

SURFACE MOUNT INSTALL SPEAKER: As above with 100v Transformer • Available in GRAPHITE or LIGHT GREY.

\$355.00

Flush Mount Ceiling Type

C516

FLUSH MOUNT INSTALLATION SPEAKER: For highest quality voice/music • Simplified Installation • Single 6.5" Mid/Bass & 1" ICT HF • 80Hz-20kHz • 50w AES • 4Ω • 90° x 90° Dispersion • 88dB Sensitivity • 233mm (OD) • Incl. Back Box and Grille • 3Kg • WHITE.

\$315.00

C516T

FLUSH MOUNT INSTALLATION SPEAKER: As C516 with Tappable 100v Transformer.

\$355.00

Subwoofer For C Series

CS265

ULTRA COMPACT SUBWOOFER: Provides Extended Low Frequency for Systems with up to 4 x C115 or C516 • 200w AES • Double 6.5" Bass Drivers • 60-100Hz • 4Ω • 93dB Sensitivity • 118dB Peak SPL • 215x456x605 (WxHxD) • 17.5Kg • BLACK

\$945.00

IMPORTANT NOTE:

Martin Audio Speakers are priced per unit - NOT PAIRS

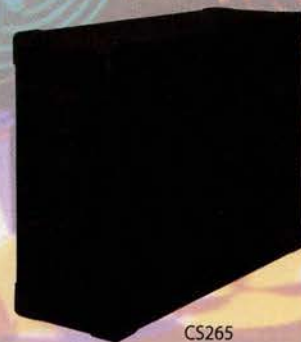

CS265



EM SERIES: Clean System Speakers Designed For Installed Sound

EM26 **\$1,395.00**
 8" 2-WAY INSTALL SPEAKER: Trapezoidal Cabinet with 8" Mid/Bass and 1" Compression Driver HF on Wooden Horn Flare • 70Hz-18kHz • 120dB Peak SPL • 8Ω • 70° x 50° Dispersion • Omni-mount Inserts • 10Kg • Used with or without EMX1A Controller • BLACK.
75WA **\$185.00**

OMNIMOUNT BRACKET FOR EM26: For Wall Mounting • BLACK.
75CA-MP **\$185.00**

OMNIMOUNT BRACKET FOR EM26: For Ceiling Mounting • BLACK.
EM56 **\$1,995.00**
 10" 2-WAY INSTALL SPEAKER: Trapezoidal Cabinet with 10" Mid/Bass and 1" HF on Wooden Horn Flare • 75Hz-18kHz • 123dB Peak SPL • 8Ω • 70° x 40° Dispersion • Omnimount Inserts • 14.5Kg • Used with or without EMX1A Controller • BLACK.

EM76 **\$2,995.00**
 12" 2-WAY INSTALL SPEAKER: Trapezoidal Cabinet with 12" Mid/Bass and 1" Compression Driver • 60Hz-18kHz • 126dB Peak SPL • 8Ω • 70° x 40° Dispersion • 10 x M8 Flying Inserts and Pole Mount • 23.5Kg • Requires EMX1A Controller • BLACK.
100WA **\$215.00**

OMNIMOUNT BRACKET FOR EM26: For Wall Mounting • BLACK.
100CA-MP **\$215.00**

OMNIMOUNT BRACKET FOR EM26: For Ceiling Mounting • BLACK.

EM186 **\$5,995.00**
 15" 3-WAY INSTALL SPEAKER: Trapezoidal Cabinet with Rotatable Mid/High Baffle for Horizontal Mounting • 15" Bass, 6.5" Mid and 1" HF • 55Hz-18kHz • 130dB Peak SPL • 3Ω • 65° x 40° Dispersion • 12 x M8 Flying Inserts • 36Kg • Requires EMX2A Controller • BLACK.

EM201 **\$3,295.00**
 SINGLE 18" SUB-WOOFER: Direct Radiating • Floor Standing Sub • 40 - 120Hz • 12EdE Peak • 8Ω • 38Kg • Designed for use with EMX1A or EMX2A Controller to provide Crossover at 120Hz • System Limiters and Equalisation • BLACK.

EM251 **\$4,495.00**
 DOUBLE 15" SUB-WOOFER: Direct Radiating • Floor Standing Sub • 38 - 120Hz • 132dB Peak • 4Ω • 58Kg • Designed for use with EMX1A or EMX2A Controller • BLACK.

EMX1A **\$1,695.00**
 2-CHANNEL 2-WAY SYSTEM CONTROLLER: Dedicated EM Series Controller providing Crossover Functions, Limiting and Equalisation for EM23, EM56 and EM76 with or without EM201 and EM251 Sub-Woofers • 1RU.

EMX2A **\$2,495.00**
 2-CHANNEL 3-WAY SYSTEM CONTROLLER: Dedicated EM Series Controller providing Crossover Functions, Limiting and Equalisation for EM186 with or without EM201 and EM251 Sub-Woofers • 1RU.

The Dangerous EM15 System!

For quality distributed sound applications a total of 16 EM15's (configured 16Ω) can be driven by a single 2Ω capable amplifier. EM15's can be mounted either horizontally or vertically with custom 'U' shaped or Omnimount brackets.

EM15B **\$495.00**
 'DANGEROUS' DOUBLE 5" INSTALL SPEAKER: Remarkably powerful ICT based Trapezoidal Cabinet • 116dB Peak SPL • 100w • 4Ω or 16Ω Configurable • 80° x 80° Dispersion • Omnimount and 'U' Shaped Bracket Inserts • Paintable • 5Kg • BLACK.

EM150 **\$2,195.00**
 DOUBLE 10" BAND-PASS SUB-WOOFER: Suitable for 6 x EM15's Configured in Series with EM15 @ 16Ω • Ore Amplifier/No Controller Required • 45 - 200Hz • 129dB Peak • 31Kg • BLACK.

EM15 'U' **\$50.00**
 EM15 BRACKET: 'U' Shaped Bracket with Swivel on one Plane • Fits Top and Bottom inserts (Screws Supplied) • BLACK.

50WA **\$125.00**
 OMNIMOUNT BRACKET FOR EM15: For Wall Mounting.
50CA-MP **\$125.00**
 OMNIMOUNT BRACKET FOR EM15: For Ceiling Mounting.



IMPORTANT NOTE: All Martin Audio Speakers are priced per unit - NOT PAIRS

QSC Audio

PLX: The Evolution Continues



A direct technological descendant of QSC's acclaimed PowerLight, PLX brings PowerWave switching technology to new levels of affordability. Featuring Speakon outs, XLR & TRS input options, front panel mounted detented gain controls, clip limiters, high pass filters, variable speed fan cooling and DC, infrasonic, thermal & short circuit protection. All PLX models are 2RU, 34cm deep, weigh 9.5Kg and are covered by a 3 Year Warranty.

NEW!

Model	Watts per channel		
	8Ω	4Ω	2Ω
PLX1202	215	400	550
PLX1602	325	600	800
PLX2402	475	800	1250
PLX3002	625	1050	1500
PLX3402	800	1250	1700

EIA: 1 kHz @ 1% THD

- PLX1202** **\$1,895.00**
2-CH POWER AMPLIFIER: 400w/4Ω • 550w/2Ω per Channel.
- PLX1602** **\$2,595.00**
2-CH POWER AMPLIFIER: 600w/4Ω • 800w/2Ω per Channel.
- PLX2402** **\$3,195.00**
2-CH POWER AMPLIFIER: 800w/4Ω • 1250w/2Ω per Channel.
- PLX3002** **\$3,795.00**
2-CH POWER AMPLIFIER: 1050w/4Ω • 1500w/2Ω per Channel.
- PLX3402** **\$4,395.00**
2-CH POWER AMPLIFIER: 1250w/4Ω • 1700w/2Ω per Channel.

MX SERIES: QSC's Heavyweight Muscle.

MX SERIES established QSC's reputation for rugged reliability. The five model range features: Barrier Strip and balanced inputs, stereo/bridged mono/parallel input options, front panel gain control, automatic 2 speed fans, touch-proof binding post outputs and independent DC, sub audio speaker, thermal overload and short circuit protection. MXa models provide card slots for various processing and input functions (see input accessories below). 3 year warranty.

MX 1500a **\$2,895.00**

2-CH POWER AMPLIFIER: 600w/4Ω, 750w/2Ω per Ch • 2-Step Output Circuit • Independent Split-Secondary Power Supply • Standard MX Series features (as above) • 19Kg • 2RU.

MX 2000a **\$3,595.00**

DUAL MONAURAL POWER AMPLIFIER: 725w/4Ω • 1000w/2Ω per Ch • 2-Step Output Circuit • Fully Independent Channels with Individual Power Supplies • Standard MX Series features (as above) • 24.5Kg • 3RU.

MX 3000a **\$4,995.00**

DUAL MONAURAL POWER AMPLIFIER: 1300w/4Ω • 1600w/2Ω per Ch • 3200w/4Ω Bridged Mono • Built-in Clip Limiter • 3-Step Output Circuit • Fully Independent Channels with Individual Power Supplies • Standard MX Series features (as above) • 31Kg • 3RU.

MXa-XP **\$395.00**

EXTRA PROTECTION OPTION: MX-1 (XLR Input Card) & SPL-1 (Configurable Compressor/Limiter Card) for MX1500/2000/3000.

MXa NL4MP **\$115.00**

SPEAKON OUTPUT OPTION: For 1500/2000/3000.

Model	Watts per channel		
	8Ω	4Ω	2Ω
MX1500a	400	600	750
MX2000a	375	725	1000
MX3000a	850	1300	1600

EIA: 1 kHz @ 1% THD
*1 kHz, 1% THD



Input Accessories For MX Amplifiers

MX-1 **\$205.00**

INPUT MODULE: Balanced XLR & Jack Input Module (Fits in Upper Slot)

XC-1 **\$395.00**

CINEMA CROSS-OVER MODULE: (Fits in Upper Slot)

SF-1 **\$445.00**

SUBWOOFER BANDPASS FILTER MODULE: Adjustable Sub Bandpass Filtering and optional Mono-Summing and B6 Equalisation (Fits in Upper Slot)

SPA-2 **\$745.00**

STEREO PRECISION ATTENUATOR/LIMITER MODULE: Attenuates in 1dB Steps • Subsonic Filter • CD Horn EQ • Remote Gain Control (Fits in Lower Slot)

SPL-1 **\$395.00**

STEREO LIMITER MODULE: 'Complete Speaker Protection' • Adjustable Compressor/Limiter (Rate & Threshold) • Mounts onto Lower Slot Input Card.

UF-2 **\$395.00**

STEREO UNIVERSAL FILTER: Adjustable Fourth Order HP and LP Filters and CD Horn EQ for each Channel • Also Functions as a Basic Active Crossover • Mounts onto standard Lower Slot Input Card.

RR-EARS **\$95.00**

REAR RACK EARS: For any 2 or 3RU Amplifier



RMX: The Watts Per Dollar QSC

The all new RMX range provides professional quality power amplifiers at new affordable price points. Three models, 2RU each and less than 400mm deep, provide a comprehensive set of features including XLR and 1/4" balanced outputs, Speakon and binding post outputs, clip limiters and low frequency filters, front panel gain controls, independent DC and thermal overload protection on each channel and 3 year warranty.

- RMX850** **\$1,395.00**
2-CH POWER AMPLIFIER: 300w/4Ω • 430w/2Ω per Ch • 16Kg.
- RMX1450** **\$1,595.00**
2-CH POWER AMPLIFIER: 450w/4Ω • 700w/2Ω per Ch • 18.2Kg.
- RMX 2450** **\$2,195.00**
2-CH POWER AMPLIFIER: 750w/4Ω • 1200w/2Ω per Ch • 2RU • 20.2kg.

RMX

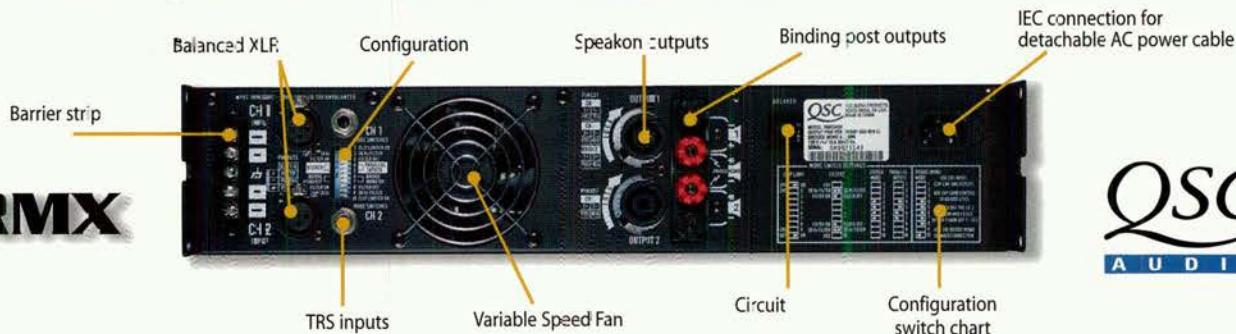

POWERLIGHT 2: Even A Multi Award Winner Can Be Improved!

The PL2 Range continues the proven track record of the Powerlight Series with unique added features. The four models range in power from 900 watts to 1800 watts/ch (2 ohms) in a 2-FL 9.5 Kg. chassis. PL2's feature: swiccheable clip limiters, data port for computer control, selectable low frequency roll off filters (5 Hz, 30Hz or EC Hz), variable speed fans with optional air filter, 1/4" TRS, 3-pin XLR and 3-pin detachable terminal block inputs, Neutrik Speakon and binding post outputs, stereo/bridged mono/rotacion, locking IEC power cable and 3 year warranty.

- PL-218** **\$2,995.00**
2-CH POWER AMPLIFIER: 600w/4Ω, 900w/2Ω per Ch • 2RU • 9.5 Kg.
- PL-224** **\$3,595.00**
2-CH POWER AMPLIFIER: 825w/4Ω, 1200w/2Ω per Ch • 2RU • 9.5 Kg.
- PL-230** **\$4,195.00**
2-CH POWER AMPLIFIER: 1250w/4Ω, 1500w/2Ω per Ch • 2RU • 9.5 Kg.
- PL-236** **\$4,695.00**
2-CH POWER AMPLIFIER: 1300w/4Ω • 1350w/2Ω per Ch • 2RU • 9.5 Kg.



PL2

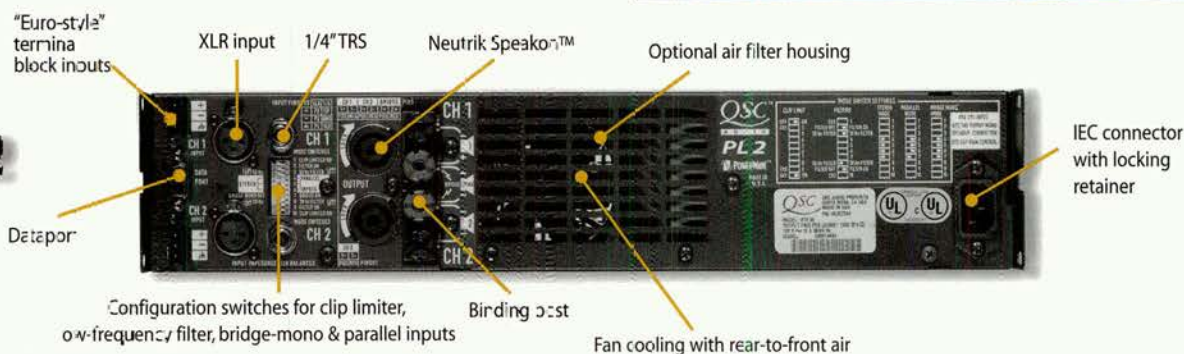

Powerlight: The Touring Benchmark

PowerLight is QSC's most comprehensive range and features: switchable clip limiters, data port for computer control, variable speed fans, barrier strip and Neutrik Combo inputs, stereo/bridged mono/parallel input options, front panel gain controls, binding post cuts, DC/sub audio/thermal/short circuit protection and 3 year warranty.



Powerlight 9.0PFC

PowerLight 6.0PFC and 9.0PFC are based on a new class of amplifier which incorporates Power Factor Correction to achieve the highest density of power available in a professional power amplifier.

QSC engineered this compact powerhouse using several breakthroughs in power supply technology and output circuit design. Foremost is power factor correction (PFC). PFC lowers peak AC current requirements by as much as 40%, reducing the strain on AC distribution. This is a critical issue for megawatt amplifiers where extreme power requirements can exceed available supplies, taxing the AC system and/or limiting amplifier output.

The output circuit is equally innovative. State-of-the-art high speed components and large-die, N-channel MOSFETs combine with a four-tiered DC supply to yield efficiency comparable to class D designs. The extreme power capability of modern MOSFETs allows a 7-to-1 improvement over normal bipolar audio transistors.

Line and load regulation is also featured making the amplifier's peak power capacity insensitive to drops in incoming AC voltage. The power supply design incorporates true soft start, automatic AC over voltage protection, and a frequency-invariant design that operates on any incoming AC frequency. Like all PowerLight amplifiers the PL9.0PFC comes complete with data port for amplifier monitoring, flow-through cooling with fully variable-speed fans, a standby mode plus both Neutrik Speakers and special shrouded speaker terminals to handle the unprecedented power.

Model	Watts per channel		
	8Ω	4Ω	2Ω*
PL 1.0	250	400	500
PL 1.0HV	350	500	nr
PL 1.4	400	550	700
PL 1.5X ^{ch-1}	300	400	500
ch-2	450	700	1000
PL 1.6HVX ^{ch-1}	350	500	nr
ch-2	725	1000	nr
PL 1.8	450	700	900
PL 2.0HV	650	1000	nr
PL 2.4MB ^{mono}	1000	1600	2000
PL 3.4	825	1200	1700
PL 4.0	1000	1600	2000
PL 6.0PFC	1700	2200	3000
PL 9.0PFC	1900	3200	4500

EIA: 1 kHz @ 1% THD
nr=not rated



PL 9.0 PFC

PL 1.0 \$3,295.00

LIGHTWEIGHT 2-CH POWER AMPLIFIER: 400w/4Ω, 500w/2Ω per Ch • 2RU • 8.2Kg.

PL 1.0HV \$3,495.00

LIGHTWEIGHT 2-CH POWER AMPLIFIER: 500w/4Ω per Ch • High Voltage version optimised for performance at 8 and 4Ω loads • Ideal for Single Box Passive PA Systems • 2RU • 8.2Kg.

PL 1.4 \$3,795.00

LIGHTWEIGHT 2-CH POWER AMPLIFIER: 550w/4Ω, 700w/2Ω per Ch • High Efficiency 2-step Output Circuit • 2RU • 8.2Kg.

PL 1.5X \$3,795.00

LIGHTWEIGHT BI-AMP POWER AMPLIFIER: One Ch of PL1.8 and one Ch of PL1.0 (700w + 400w/4Ω) for Bi-Amp applications in active Stage Monitors or FOH PA Speakers • X-Over Card Option (See Below) • 2RU • 8.2Kg.

PL 1.6HVX \$3,995.00

LIGHTWEIGHT BI-AMP POWER AMPLIFIER: One Ch of PL2.0HV and one of PL1.0HV (1000w + 500w/4Ω) • High Voltage version for 8 and 4Ω loads • Optimised for large active 2-Way speakers • X-Over Card Option (See Below) • 2RU • 8.2Kg.

PL 1.8 \$4,495.00

LIGHTWEIGHT 2-CH POWER AMPLIFIER: 700w/4Ω, 900w/2Ω per Ch • Two Variable Speed Fans • 2RU • 8.2Kg.

PL 2.0HV \$4,795.00

LIGHTWEIGHT 2-CH POWER AMPLIFIER: 1000w/4Ω per Ch • High Voltage version optimised for performance at 8 and 4Ω loads • Ideal for Large Single Box Passive PA Systems • 2RU • 8.2Kg.

PL 2.4MB \$4,495.00

LIGHTWEIGHT 1-CH POWER AMPLIFIER: 1600w/4Ω, 2000w/2Ω • Single Channel of PL4.0 in PL1.8 Chassis • 2RU • 8.2Kg.

PL 3.4 \$6,495.00

LIGHTWEIGHT 2-CH POWER AMPLIFIER: 1200w/4Ω, 1700w/2Ω per Ch • Dual Mono High Efficiency 3-Step Output Circuit • 3RU • 13.6Kg.

PL 4.0 \$7,495.00

LIGHTWEIGHT 2-CH POWER AMPLIFIER: 1600w/4Ω • 2000w/2Ω per Ch • Dual Mono High Efficiency 3-Step Output Circuit • 3RU • 13.6Kg.

PL 6.0PFC \$13,995.00

LIGHTWEIGHT 2-CH HIGH POWER AMPLIFIER: 2200w/4Ω • 3000w/2Ω per Ch • Dual Mono High Efficiency Power Supply with Power Factor Correction to Operate on a Standard 15A Outlet (As PL9.0PFC) • 3RU • 27Kg.

BSC/UF-2 \$595.00

CROSS-OVER CARD OPTION: Internally Mounted Cross-Over Card Kit for 2RU PowerLights.

BSC/SPL-1 \$595.00

POWER LIMITER CARD OPTION: Internally Mounted Power Limiter Card Kit for 2RU PL's.

PL 9.0PFC \$15,995.00

LIGHTWEIGHT 2-CH EXTREMELY HIGH POWER AMPLIFIER: 3200w/4Ω, 4500w/2Ω per Ch • Dual Mono High Efficiency Power Supply with Power Factor Correction to Operate on a Standard 15A Outlet • Standard PowerLight features (as above) • 3RU • 27Kg.

USA SERIES: The Installation Standard



Model	Watts per channel		
USA	8Ω	4Ω	2Ω
400	25	200	250
900	270	450	500

EIA: 1 kHz, 1% THD

USA Series includes: built-in limiting (switchable), selectable high-pass filters (30Hz, 50Hz or Out), barrier strip and balanced Neutrik Combo Ins (XLR & Jack), stereo/bridged mono/parallel input options, rear mounted gain control, touch-proof binding post outputs, full short circuit protection, thermal, ultrasonic and RF protection and 3 year warranty.

USA 400 **\$1,395.00**

2-CH POWER AMPLIFIER: 200w/4Ω per Ch • Class AB • Convection Cooled (Ideal for Studios/Control Rooms) • Standard USA Series features • 10.9Kg • 3RU.

USA 900 **\$1,695.00**

2-CH POWER AMPLIFIER: 450w/4Ω per Ch • 2-Speed Fan Cooling • Standard USA Series features • 15.4Kg • 3RU.

USA OT-185 **\$400.00**

100 / 70V OUTPUT TRANSFORMER FOR USA400: 2-Ch Bolt-On Unit Containing Two Toroidal Output Transformers • 185w/Ch Output @ 100/70v.

USA OT-425 **\$545.00**

100 / 70V OUTPUT TRANSFORMER FOR USA900: 2-Ch Bolt-On Unit Containing Two Toroidal Output Transformers • 425w/Ch Output @ 100/70v.

DCA SERIES:

Digital Cinema Amplifiers

DCA 1222 **\$2,195.00**

2-CH POWER AMPLIFIER: 375w/4Ω • 600w/2Ω per Ch.

DCA 1622 **\$2,795.00**

2-CH POWER AMPLIFIER: 550w/4Ω • 800w/2Ω per Ch.

DCA 2422 **\$3,395.00**

2-CH POWER AMPLIFIER: 825w/4Ω • 1200w/2Ω per Ch.

DCA 3022 **\$3,995.00**

2-CH POWER AMPLIFIER: 1050w/4Ω • 1500w/2Ω per Ch.

DCA 3422 **\$4,495.00**

2-CH POWER AMPLIFIER: 1250w/4Ω • 1700w/2Ω per Ch.

DCA 1644 **\$2,995.00**

4-CH POWER AMPLIFIER: 4 x 250w/4Ω.

DCA 1824 **\$2,995.00**

4-CH POWER AMPLIFIER: 4 x 170/4Ω • 4 x 450w/2Ω.

XC-3 **\$445.00**

CINEMA CROSS-OVER WITH DELAY: Two-Way Crossover (or 3-Way with LF-3) with Adjustable Frequency, Selectable HF Boost, HF Trim & 4th Order Linkwitz-Riley, with 24dB/Octave Slope

LF-3 **\$445.00**

LOW-FREQUENCY FILTER WITH DELAY: Used with XC-3 as HP Filter with Adjustable Freq., 0-20dB Attenuation, 4th Order Linkwitz-Riley with 24dB/Octave Slope

SF-3 **\$445.00**

SUBWOOFER FILTER: Adjustable Sub Bandpass Filter with Switchable 6dB Boost, Selectable Frequency and LF Filter



DCA is an all new line of amplifiers that deliver the added dynamic range and audio performance required by today's digital soundtracks. Incorporating QSC's exclusive PowerWave technology, DCA's produce cleaner highs and sea-shaking bass. The five 2-Channel models are 2RU, 50mm deep, just 9.5kg and feature: Data port for crossovers and monitoring, Dip switch control for clip limiters, HP filter, bridge-mono and parallel operation, XLR, TRS and Euro style inputs, Speakon and Barrier strip outputs, a custom integrated security cover for tamper proof installations, zero-idle speed fan for low noise, 1dB detented gain controls, active inrush limiting to eliminate inrush current at turn-on, comprehensive protection circuitry including DC, inrush, thermal overload and short circuit and 3 year warranty.

Model	Watts per channel		
DCA	8Ω	4Ω	2Ω
1222	215	375	600
1622	325	550	800
2422	475	825	1200
3022	625	1050	1500
3422	800	1250	1700

EIA: 1 kHz, 1% THD

CX SERIES: Contractor Amplifiers

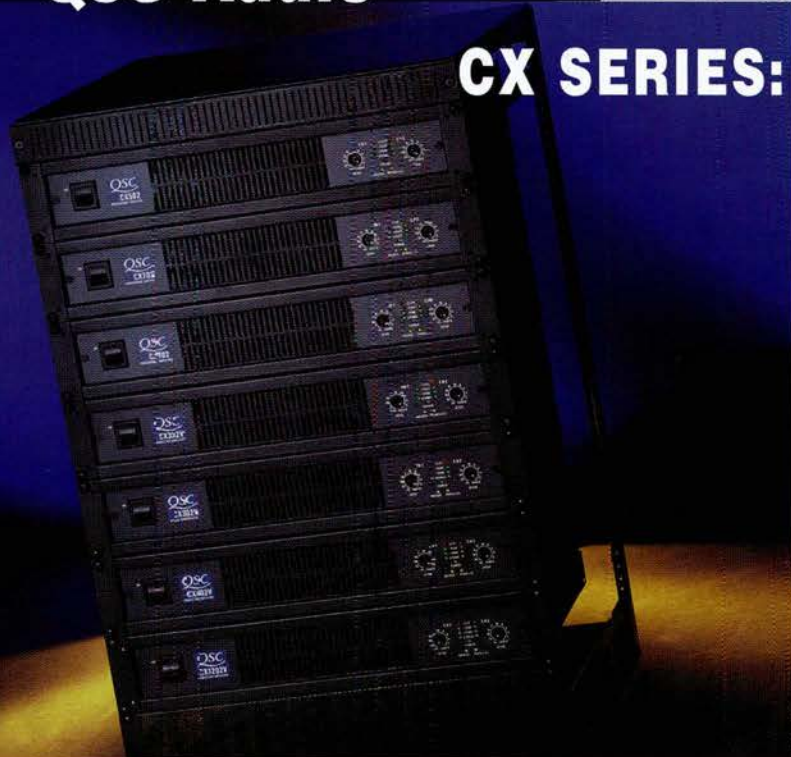

- CX302V** **\$2,295.00**
2-CH 70v LINE POWER AMPLIFIER: 250w @ 70 per Ch.
- CX602V** **\$3,395.00**
2-CH 70v LINE POWER AMPLIFIER: 550w/8Ω • 440w @ 70 per Ch.
- CX1202V** **\$3,995.00**
2-CH 70v LINE POWER AMPLIFIER: 1100/4Ω • 1000w @ 70 per Ch.
- CX302** **\$2,295.00**
2-CH POWER AMPLIFIER: 325w/4Ω • 600w/2Ω per Ch.
- CX502** **\$2,795.00**
2-CH POWER AMPLIFIER: 500w/4Ω • 800w/2Ω per Ch.
- CX702** **\$3,395.00**
2-CH POWER AMPLIFIER: 700w/4Ω • 1200w/2Ω per Ch.
- CX902** **\$3,995.00**
2-CH POWER AMPLIFIER: 900w/4Ω • 1500w/2Ω per Ch.
- CX1102** **\$4,395.00**
2-CH POWER AMPLIFIER: 1100w/4Ω • 1700w/2Ω per Ch.
- CX302/IT42** **\$2,595.00**
2-CH 100v LINE POWER AMPLIFIER: 400w @ 100v per channel (Incl. IT-42 Bolt-on Transformer Pack) • 2RU.

4 Channel Installation Amplifiers

- CX254** **\$2,995.00**
4-CH POWER AMPLIFIER: 4 x 250w/4Ω, 4 x 450w/2Ω • 2RU
- CX404** **\$2,995.00**
4-CH POWER AMPLIFIER: 4 x 400w/4Ω • 2RU
- CX204V** **\$2,995.00**
4-CH 70v LINE POWER AMPLIFIER: 4 x 200w/70v • 2RU

Model	Watts per channel			
	70V	8Ω*	4Ω*	2Ω**
302V	250	•	•	•
602V	440	550	•	•
1202V	1000	700	1100	•
302	•	200	325	600
502	•	300	500	800
702	•	425	700	1200
902	•	550	900	1500
1102	•	700	1100	1700

* kHz, 0.5% THD
 **1 kHz, 1% THD
 ***1 kHz, 1% THD

The new CX Series is designed to meet the specialised needs of the sound contractor. Eight 2-channel and three 4-channel models, including 70v output, have been designed from the ground up, combining QSC's exclusive PowerWave technology with contractor-specific features to meet the requirements of fixed installations. All new CX models are 2RU, 350mm deep, just 9.5Kg and feature: HD15 DataPort connector for computer control, Dip switch control for clip limiters, HP filter; bridge-mono and parallel operation, XLR and Euro style inputs, Barrier strip outputs, a custom integrated security cover for tamper proof installations, variable speed fan with zero-idle for low noise, 1dB detented gain controls, active inrush limiting to eliminate inrush current at turn-on, comprehensive protection circuitry including DC offset, thermal overload and short circuit and 3 year warranty.



RAVE @ Superbowl 1999

Model	Input	Output
	Audio Channels	Audio Channels
Analog	RAVE 160	16
	RAVE 161	16
	RAVE 188	8
Digital	RAVE 80	16
	RAVE 81	16
	RAVE 88	8

RAVE: Routing Audio Via Ethernet

RAVE is a digital routing system which allows multiple channels of uncompressed 20-bit digital audio and control/monitoring signal to be routed in real-time over standard Ethernet networks. The six units are multiplexer modules providing the audio inputs and outputs to and from the network.

- RAVE160** **\$6,495.00**
DIGITAL AUDIO ROUTING SYSTEM: 16 Analogue Output Channels • 1RU.
- RAVE161** **\$7,995.00**
DIGITAL AUDIO ROUTING SYSTEM: 16 Analogue Input Channels • 1RU.
- RAVE188** **\$7,495.00**
DIGITAL AUDIO ROUTING SYSTEM: 8 Output/3 Input Analogue Channels • 1RU.
- RAVE80** **\$5,995.00**
DIGITAL AUDIO ROUTING SYSTEM: 16 Digital Output Ch (AES/EBU Format) • 1RU.
- RAVE81** **\$7,495.00**
DIGITAL AUDIO ROUTING SYSTEM: 16 Digital Input Ch (AES/EBU) • 1RU.
- RAVE88** **\$6,995.00**
DIGITAL AUDIO ROUTING SYSTEM: 8 Out/8 In Digital Audio Ch (AES/EBU) • 1RU.



Specialist Sound Technology

SST products provide highly effective solutions for applications when requirements pass the limitations of conventional speakers. BCA 500 offers tight pattern control and full range performance for areas with excessive reverberation characteristics.

The BCA 500 *Beam Control Array* provides controlled coverage which minimises feed-back and audience 'hot spots' common with horn/woofer speakers. The low frequency extension is substantially greater than competitively priced systems using 300mm woofers or other so called line arrays.

The system comprises seven transducers; six 133mm cone drivers cover the region between 70Hz to 2.5kHz and one radial horn compression driver covers the high frequencies between 2.5kHz and 16kHz.

A complex 36 element CAD designed, 4 way filter network controls the vertical dispersion and provides smooth accurate spectral response across the entire operating range of the system.

SST products are designed and manufactured in Australia.

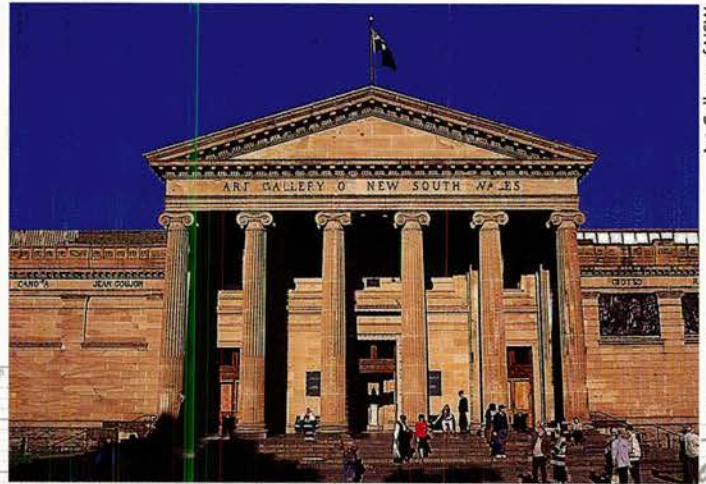

Art Gallery of NSW

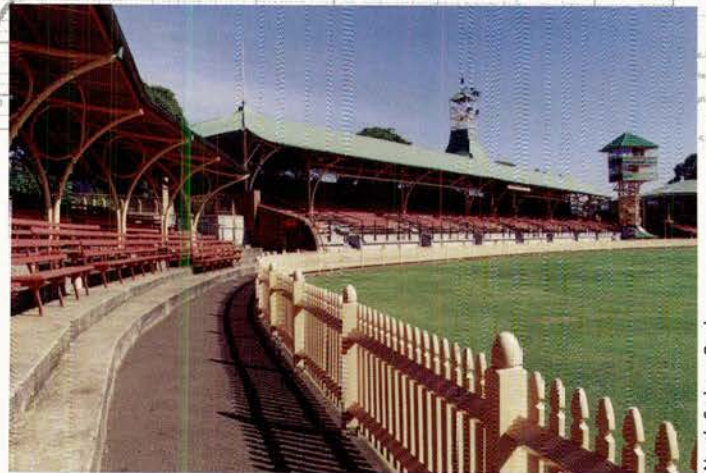

North Sydney Oval



Log Magnitude (10 dB/div)

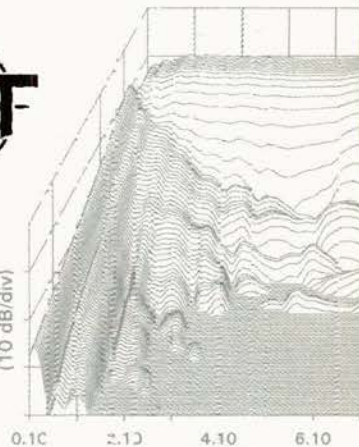

Gallery @ Parliament House, Canberra

BCA500 \$2 195 00

BEAM CONTROL ARRAY COLUMN SPEAKER: Designed for Highly Reverberant Environments (Churches, Stadia Galleries, Function Halls, etc) • Tightly Controlled 95° x 40° Dispersion • Directivity Factor 6 • Six 5.5" Mid/Bass and HF Horn • 70Hz-16kHz • 92.5 dE 1w/1m • 150w continuous FinC No se • 300w watts peak • OmniMount/Pole Mount system • 25.5Kg.

BCA500T \$2,450.00

BEAM CONTROL ARRAY COLUMN SPEAKER: As BCA500 with Tappable 150w High Spec Constant Voltage Toroidal Transformer • 2E.5 kg.

Ricky Martin, sex God

of female hysteria. Even with the vengeful claws of a V-DOSC PA system, supplied by Westfalen Sound (in Europe only) to the main tour vendor, Audiotek.

While Colby soldiered on at FOH, as a replacement for Steve Guest, Monitor Engineer Raphael Alkins did an admirable job of controlling 15 stereo mixes via a stack of hard-wired and wireless Garwood Radio Stations and Futuresonics in-ear systems, plus EAW KF850 sidefills. This system, part of a monitor kit list furnished by Firehouse Productions, provided superb quality feeds to Martin and his 14-piece band, with all the reverbs and delays sending and returning in stereo.

Ricky and the guitarists, horn players and backing singers all move around a lot, so they're all on wireless packs. Alkins indicated that the drummer, percussionists and keyboard players stay on hard-wired systems.

"Futuresonics have been with Ricky from the start, and he now owns a complete Futuresonics IEM rig, which has been modified for us with a new switching system. We also have a Futuresonics-designed +18dB amplifier with one antenna combiner, which makes things a lot easier, especially when you come to the UK. There is so much RF out here, you want to be able to isolate what you're doing on stage. It's a little expensive but when you think about what is going on here, you cover your ass as much as you can!"

The IEM situation here is a little more interesting than normal, owing to attention given by Alkins to drummer Waldo Madera's buttocks! Alkins laughed, "Yeah, the drummer has a Futuresonics stereo butt shaker in his stool, so that when he does a tom fill from left to right, he feels it from left to right. His whole mix is designed to be geographic, in

terms of the placement of drums and cymbals. He was amazed when he heard it, but it makes total sense."

Alkins, sight of the band appeared compromised by the sheer amount of aluminium in the set, and although he insisted it wasn't a major problem (thanks to a CCTV system aid), he did vent his frustration at the lack of thought for audio when the show was designed.

"Set designers [in this instance, Bruce Rogers] spend so much time deciding how the show will look, then consider the audio last of all. The aluminium in the set has caused some bad RF reflections and it was one of the reasons we brought in the antenna combiner, putting antennae all round the stage to create a dome, so we're actually injecting and drawing out RF. Of course, if the set people had involved us at the start during our rehearsals at the Laker Forum in L.A., these things wouldn't have happened."

The RF situation was assisted by Wireless Technician William Benevides who monitored 35 frequencies independently of Alkins on a Yamaha O1V - to predict any potential interference problems.

CHAMPIONING THE PARAGON

Previously a Yamaha PM4000 user, Alkins began this tour with a new ATI Paragon II desk, joining an ever-growing list of satisfied engineers. He told us: "We had the chance to go to the ATI factory and watch a console being built. No console has ever been designed to make any engineer 100% happy, and it will never happen. But it is possible to get 95% of the way there and the Paragon II is as close as you'll get."

"This model does not have the automation or the mute groups, only because they weren't ready. But that doesn't cause me any grief on this show because it has Solo-in-Place mode, and all I have to do is go to that mode and cue the audience microphones, which is how the show ends, then fade the signal in and out. If you apply yourself properly, you



From top - Lighting Designer Peter Morse
Sound Crew Chief Ron Tripeny
FOH Engineer Rob 'Cubby' Colby
Alkins in deep discussion with Peter Barnard of ATI distributor European Audio Group
Far left: V-Dosc system hanging proud during rigging.

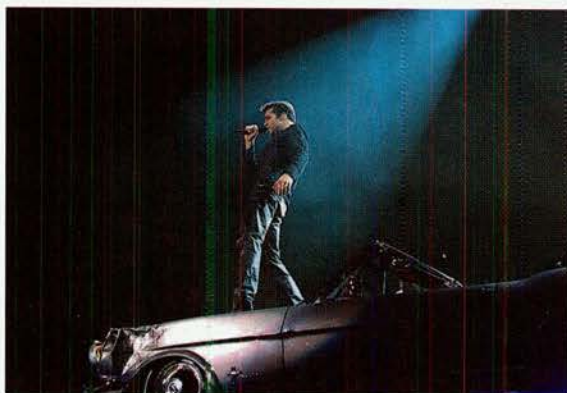
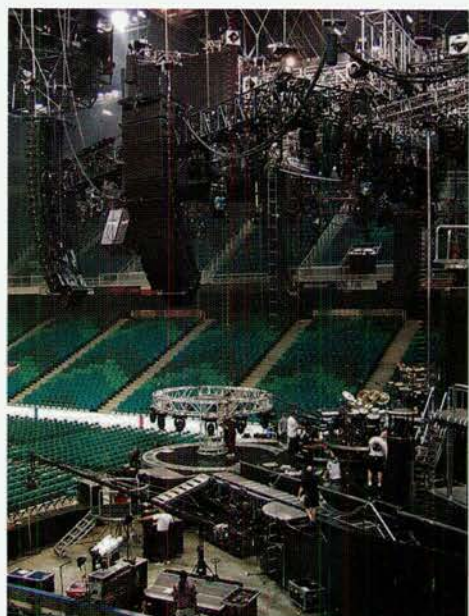

Ricky Martin, sex God

get around it."

"The PM4000 couldn't cope with this show. In total, this console is handling 20 stereo mixes and it's maxed out. I also have 12 stereo input modules, which is a very desirable feature because so few modern desks have them. The modules don't take up any more space than a regular mono strip." Faced with a number of high quality choices, it was, Alkins said, ATI's overall treatment of his needs that won him over.

"Service is of paramount importance when you're on the road. I have an artist who is putting a lot of trust in me and I cannot afford to let him down. With ATI, I have had nothing but good experiences. I was very pleased to get an instant response from the European Audio Group [the sole UK distributor and full 24-hour technical and repair service for ATI products] who ensured that a power supply replacement arrived early the following day. If ever there is a malfunction of any kind, I have been put through directly to someone who can communicate with me and go through the problem on the phone. It's the same with Futuresonics. Other companies will put you on hold for a day or two. One major microphone manufacturer took two months to come back to me and that just is not good enough for anyone, let alone a tour at this level."

Alkins, whose engineering credits include Patti LaBelle, Anita Baker, Barry White and Huey Lewis & The News, did pick up on one particular aspect of the Paragon II, which he believed could be improved. He commented: "All of the internal dynamics [comps and gates] only work post-fader and post-VCA, as you might find on other desks. Unfortunately, on this show only Ricky and the band's MD are post-fader. There are a lot of moves in between snapshots that I take in the show, so I have to use external comps and gates for the rest of the band. I'd like my stereo returns come to VCAs, and have my comps and gates come pre- AND post-fader, but the costs involved in making these wishes come true would make the desk the most expensive in the world, probably!"

"I don't really like having coloured knobs, but hey, I'm getting picky! Above all, it sounds great, there's a ton of headroom, and armed with a console with this level of performance and second-to-none service back-up, why should I be even remotely interested in another brand?"

In Alkins' rack were two t.c. Electronic 2000s and a 3000 reverb, whose snapshot features have helped the engineer through a cue-hungry production. A bank of Aphex Dominator IIs provided mild compression control for the IEMs and excellent status monitoring. He also cited the BSS DPR-901 as a major "get out of jail, processor for Martin's vocal."

"The Sony 840 microphone has some weird characteristics that make Ricky's voice sound harsh. The pre-amps in the Paragon sound great, but I want to have the flexibility of changing the desk during the show. So I take the harshness out and keep the EQ on the desk flat for later that night if temperatures change."

The Sony 840 was Martin's preferred option to the Sennheiser 5000 series, of which Alkins said it "didn't match his voice". He added: "Ricky likes the extra control that a power and mute switch gives him. He goes to the dressing room three or four times during the show, and mutes the microphone without powering it down. In the previous show, he had runways in front of the PA and would walk right along by the cabinets and mute the microphone as he walked through, then put it back on as he got to the other side. He was very together in that respect. In an ideal world, no engineer likes to give that control to an artist, but Ricky is totally dependable."



POWER CURVES



The beauty of a Celestion KR Series Loudspeaker is much more than skin deep. Elegantly styled cabinets combine with purpose - designed Celestion driver systems to deliver a package of quality sound and stunning looks that will enhance the atmosphere of any bar or restaurant.

And a range of custom hardware, plus OmniMount™ compatibility, ensures that installation is swift and simple.

So if you need speakers that look great and sound even better, talk to Celestion today about the KR Series.



CELESTION

**GREATER
UNION
ENTERTAINMENT
TECHNOLOGY**

Distributed by GUET SVL Distribution
Australia: 37 Mars Road, Lane Cove 2066

Ph: (02) 9418 6029 Fax: (02) 9418 9801 Email: mardella_colli@s@guet.com.au
New Zealand: Unit E, E65 Great South Road, Perrose, Auckland
Ph: 64 9 579 4082 Fax: 64 9 579 4084 Email: kkrroll@guet.co.nz

THE MORSE CODE

It was last August that Lighting Designer Peter Morse first realised the massive scale of the fantasy that Martin and Jamie King, his Artistic Director, had managed to conjure.

Morse's challenge was three-fold: to illuminate all of the intended "gags", when there was pitifully little space allocated for the hanging of lights; to properly backlight the entire scenario, when the rig was 45 to 50 feet in the air, and designed in such a way to prevent much backlight from occurring; and produce a light show on roughly one-quarter of the necessary budget.

Several meetings with Set Designer Bruce Rogers led to a mutual appreciation of each other's tasks although Morse was continually informed of more flying and hanging "gags", that would eventually interfere with the existing lighting positions. His main concern was that a lack of lighting points would mean that many of these tricks would remain unseen. Such nightmares were addressed at the L.A. rehearsals, and it was Lighting Crew Chief Robert Cooper who is credited by Morse for mostly helping to "massage the system into place", and satisfactorily illuminate all viable areas of the show.

The basic wash of the show was supplied by 120 High End Studio Color 575s. The band and dancers, lighting was accomplished with the inclusion of back, side, and front washes, while the star was highlighted with various moods and patterns of backlight (70 Studio Spots, 24 Cyberlights and 22 Vari*Lite VL7s), and carefully positioned Lycian 1200W truss spots, and 2kW/3kW in-house follow spots.

With lighting direction on the tour handled by Butch Allen and Eduardo Rodriguez, the remainder of the rig (operated by two Wholehog II desks) included 11 Par 64 ACL bars for the audience, seven Par 46 ACL bars under the turntable, plus eight DF-50 foggers and two F-100 smoke machines.

Morse commented: "While the overall intensity and excitement of the look of the show was of primary importance, I felt that the depth and drama were equally important. Shadows became important, especially in moody areas of the music. After all, drama is not always in your face, but also exists in that which is not readily obvious to the eye or the ear."

The LD also included the use of Arri 2.5kW Fresnels, mounted on Compulite automated yokes and colour changers, and lowered into a variety of heights on motorised 25' Panaglyphs. This became a powerful effect when, as Martin rose into the "clouds", on a flying platform, the Arris were lowering in, past him and down to head height. The contrast in motion and direction lent greater dynamics to his flying "gag". These lights also gave prominent illumination when needed on a focused area of the stage.

Programming took place in Lakeland, Florida over eight days and nights - a time frame that Morse claimed was around one-quarter of the time normally required for such a show. Said Morse: "What helped us was Ricky knowing his show, and everyone being well rehearsed. I attempted to light the show, keeping in mind that there were dancers, band, set, video, and, oh yes, Ricky! Besides all of this, I wanted to maintain a Latin feel to the entire production, while maintaining colour balance integrity for the video. Of final concern was the fact that Ricky never gets lost in all of this, and actually remains the focal point for the live



OPERA

dB Technology's Best value for money self powered speaker cabinets just got better!

Better performance, excellent value, heaps of power with a lot of class.

**Opera212, 200W RMS, rrp \$1,350
Opera215, 200W RMS, rrp \$1,550
Opera415, 400W RMS, rrp \$1,995**



Model	RMS Power	SP Size	Limiter	Fly Points	Stand Mount	Jack input	XLR input	Line input	Mic input
Opera 212	200W	12"	Yes	Yes	Yes	Yes	Yes	Yes	Yes
Opera 215	200W	15"	Yes	Yes	Yes	Yes	Yes	Yes	Yes
Opera 415	400W	15"	Yes	Yes	Yes	Yes	Yes	Yes	Yes

For more info visit the Australian distributor's web site at www.cmi.com.au/audio or phone CMI on 03 9315 2244

ZA Series Amplifiers

Could this be next year's Entech award winner?

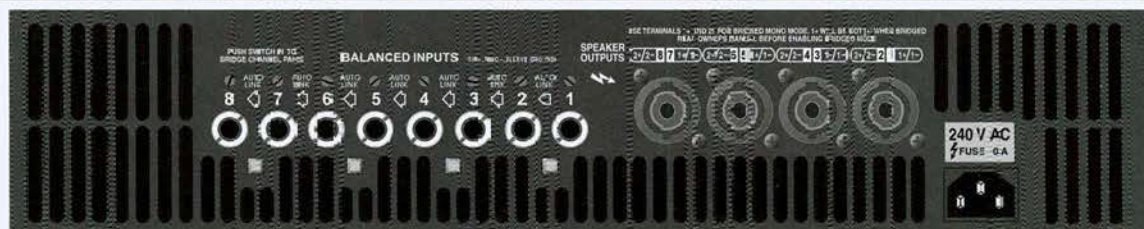
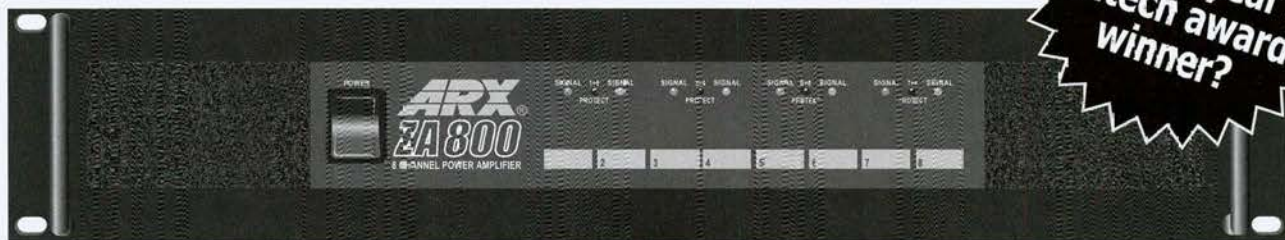

ARX is proud to introduce the all-new ZA series of multi-channel amplifiers:

ZA 800 8 Channel, 100 w/± ohms

ZA 600 6 Channel, 125 w/± ohms

ZA 400 4 Channel, 250 w/± ohms

Standard features include rear level controls, balanced inputs with exclusive AutoLink circuitry, Signal and Protect status LEDs, 4 pole

Speaker outputs, and bridged mono capability switchable per pair of channels. Dual fans, plus our exclusive 'UltraFin' heat exchanger provide excellent long term temperature stability. Built to exacting standards throughout, the ZA series from ARX has already been specified into many installations in Australia and worldwide.

If you'd like to know more about these new amplifiers, you can write, phone, fax or email us on the contact details below for a CD ROM with complete technical information on all ARX products.



ARX Systems P/L Phone (03) 9555 7859 Fax (03) 9555 6747 Email: info@arx.com.au Post: PO Box 15, Cheltenham, Vic 3192

Studiomaster TRILOGY

Professional Front of House, Recording and Foldback Console

- 166 - 12 mic/2 stereo Rackmountable*
- 206 - 16 mic/2 stereo
- 326 - 24 mic/4 stereo
- 140EX - 10 mic/2 stereo Rackmountable expander*

- Balanced mic and line inputs.
- 3 band EQ with Mid Sweep ● 6 Aux sends.
- Listen (PFL & SIF) ● 4 Stereo Aux returns.
- 48V Phantom power ● 4 Subgroups.
- Balanced XLR outputs ● Direct Outputs.
- Inserts and mutes ● High pass filters.
- Internally modular ● EP7 External power supply.
- FREE rackmount kit included.*

Studiomaster - Intelligent Audio Solutions

Distributed by: 87 Mars Road,
Lane Cove 2066
Ph: (02) 9418 6029
Fax: (02) 9418 9801
Email: mardelle_collins@guet.com.au



internally modular

trilogy 140EX

trilogy 66

trilogy 206

trilogy 326

EP7 power supply



Ricky Martin, sex God

eye. I can't say enough about Butch Allen – he's been a huge help in maintaining the continuity of the show on a daily basis."

VISION

Video played a major role in Bruce Rogers, set design. PSL Inc. supplied a complete broadcast quality video production package that comprised a five Ikegami HL59 camera system running feeds to a GBG 200 composite switcher, working in conjunction with a Magic DaVE to create special effects.

A further 32x32 matrix switcher enabled Video Designer Carol Dodds to juggle five separate images to five individual screens, a feature of the video design that recurred throughout the show, keeping Dodds at full capacity.

Video feeds were output to three Gearhouse Optiscreens totalling 42 panels - configured centre stage (6x3), stage left and stage right (3x4). Four Barco 9200s handled video projection.

The video design kept Martin centre stage, primarily shot through a 55:1 long lens from the live camera in FOH position. The dance routines of the dozen-strong dance team were related via the side screens and a further feature during the performance was provided by extra dancers bungee-ing down and dancing in front of the LED screens.

The screens proved their robust qualities around the world as every show has been broadcast via a television feed to a local TV station.

GRIDLOCKED

Production Manager Mark Spring, who had

only recently taken over from Joyce Fleming, told us that the original tour of last autumn carried a huge grid with a rigging weight of 45.8 tons (metric). This was designed to accommodate dancers and rapellers, as well as the show's bungee gags.

Said Spring: "The idea was to have as much traffic up in the air as possible, but the grid was time-consuming and way too heavy, so there was a re-design on-site. All Access Productions supplied a new grid that was simpler to put together and helped to speed up rigging times. It did not, however, reduce the weight."

While the crew struggled through the American tour, the European dates were being planned and many of the venues froze with horror at the rigging weight statistics.

"Ricky didn't have a "B" show and didn't want one. He wants the whole thing the whole time," Spring commented. "That's why the amount of dates in Europe were limited."

Meanwhile, Spring pulled out all the stops to come up with a slicker grid and went back to All Access. The results were significant. The overall weight was reduced down to 35 tons (metric). One less truck was used for the grid, and because no pre-rigs were allowed, another two trucks were disposed of. Thinner walkways were designed and medium duty trussing was applied where relative," said Spring.

Since London, the tour has returned to the States and will soon be playing to, no doubt, packed houses in Asia and Australia.

The English translation of the tour name is "living the crazy life", and few members of the crew would disagree with that.

Key Production Crew & Suppliers:

Tour Concept & Artistic Director: Jamie King. Tour Manager: Dean Lawrence. Assistant Tour Manager: Megan Ingalls. Production Manager: Mark Spring. Assistant Production Manager: Ramey Shippen. Road Manager: Beth Kittrell. Stage Managers: Scott Chase, Malcolm Weldom. PA: Audiotek/Firehouse Productions/(Europe) Westfalen Sound. FOH Engineer: Robert 'Cubby' Colby. Monitor Engineer: Raphael Alkins. Sound Crew Chief: John Tripeny. PA Technician: Sherif Al-Barbari. Sound Crew: Greg Lopez, Jose Neves. Wireless Technician: William Benivedes. Lighting: Light & Sound Design. Lighting Designer: Peter Morse. Lighting Directors: Butch Allen, Eduardo Rodriguez. Lighting Programmers: Marco Hidalgo, David Arch, Joel Young. Vari*Lite Operators: Greg Kocurek, Curry Grant. Lighting Crew Chief: Robert Cooper. Lighting Crew: Bill Boyd, Mike Finnochairo, Steve Haskins, Royston Jennings, Mike Parker, Tim Schiavone, Wendy Fletcher, Dave Grayson, Bruce Heard, Jason Hudgens. Pyro: Bob Smith, Frank Loffredo. Video: PSL, Inc.. Video Director: Carol Dodds. Video Engineer: Roy Fountain. Show Control: Gerald McReynolds. LED Screens: Sean Binns, Harry Kimmel, Jr.. Camera Operator: Joe Victoria. Video Crew: Redo Jackson, David Jolley, Donald Lovitt, Bryan Potter. Production/Set Design: Bruce Rogers/Tribe Inc.. Set Construction & Grid: Erik Eastland/All Access. Head Carpenter: Tye Trussell. Rigging: Branam Enterprises (Randy Beckman). Head Rigger: Burt Durbin. Rigging Crew: Shawn Moeller, Rick Wilmot, John Kinal, Dan Beard, Arturo Dicky, Mike Li.

CHIAYO Cost Effective Quality Audio

The frequency & the price
keep it within reach!

With frequencies in the 700 + 800 MHz range, this all new compact half rack single channel receiver gives you maximum coverage at minimum cost. True diversity reception matched with your choice of new ergonomically designed handheld mic (with inter-changeable capsule module) or lightweight belt-pack transmitter. Chiayo keeps making the very best products well within your reach.



N | S | C | A

National Systems Corporation of Australia Pty Ltd

Ph: (03) 9434 1888 Fax: (03) 9434 1866 Interstate: 1800 441 440 Email: nsca@ozemail.com.au

Expensive - Lamps!

A lamp is a lamp is a lamp – or is it....?

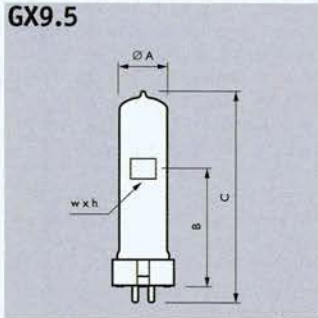

Lamp	A	B	C	W x H
CP90	28.0	67.0	120.0	16.0x14.0
CP67	22.0	55.0	110.0	11.0x12.0
CP70	28.0	55.0	110.0	15.0x13.0
T29	28.0	67.0	120.0	16.0x14.0
T19	28.0	55.0	110.0	15.0x13.0
T21	22.0	55.0	110.0	11.0x12.0

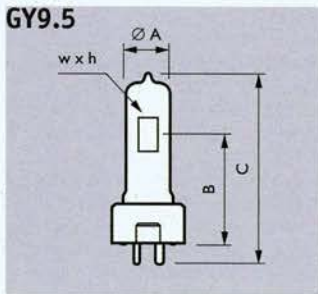

Lamp	A	B	C	W x H
CP89	22.0	46.5	90.0	11.0x12.0
CP81	18.0	46.5	90.0	6.0x13.0
CP82	18.0	46.5	90.0	8.0x18.0
T25	22.0	46.5	90.0	11.0x11.0
T27	22.0	46.5	90.0	11.0x13.0

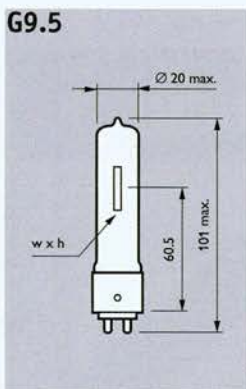

Lamp	A	B	C	W x H
CP77	20.0	60.5	101.0	7.0x21.0
GKV	20.0	60.5	101.0	13.0x8.5

Dimensions in mm

Ever been asked to change a lamp in a theatre fixture? With the myriad of different types and brands of lamps out there, it is all too easy to get confused over which ones to use. In the world of Tungsten Halogen bubbles, there are numerous base types, colour temperatures, lamp life times, wattages and voltages to contend with. A few good "rules of thumb" to remember:

- The higher the colour temperature, the lower the lamp life
- Always check a few suppliers before buying stock – as lamp prices are variable and impossible to nail down.
- Always check what are the recommended and maximum specifications for the fixture you are buying replacements for. (Some fittings are not recommended for higher wattage bubbles. Using a higher than recommended Wattage is likely to reduce lamp life, and possibly compromise or fry the electrics within a fixture)

There are now five main types of lamp base typically used in new theatrical and studio light fixtures. They are:

- G9.5 – typically used for the new axial type lamps

- GY9.5 – typically used in many 500/650W fixtures
- GX9.5 – typically used in many 1/1.2kW fixtures
- G22 – used in many 2/2.5kW fixtures
- G38 – used in many 5kW fixtures

The other types of bases you may come across are:

- GY16 – some 2kW fixtures used this lamp base
- P28s – as used in the Strand Patterns 23, 123, 223, etc.
- Par56/64 – used as the name suggests
- ES – Edison Screw (common American light bulb base)
- BC – Bayonet Cap (common Australian light bulb base)

Want to use a GKV in a Source Four?

Although the ETC Source Four fixtures do have the correct lamp base for a GKV, they have been designed for the HPL lamp - it has its filament a little further away from the lamp base. However, Philips have brought out a device called "The Sink". This little device

Lamp Comparison Table								
Lamp Base	Lamp Type	Volts	Watts	Lamp Life	Colour Temp	ANSI Code	Lumen Output	Philips Code
G9.5	HPL575WXN	240	575	1500	3050			n/a
G9.5	HPL575WCN	240	575	400	3200			n/a
G9.5	GKV	240	600	300	3200	GKV	15000	6986P
G9.5	GLB	240	600	1500	3100	GLB	13000	6991P
G9.5	CP77	240	1000	180	3200	FEP	26000	6983P
GX9.5	CP67 (CP23)	240	650	120	3200	FVD	16500	6993P
GX9.5	T21 (T12)	240	650	900	3000	-	12600	6998P
GX9.5	CP70 (CP24)	240	1000	240	3200	FVB	25000	6995P
GX9.5	T19 (T11)	240	1000	900	3050	FWR	21000	6996P
GX9.5	T29	240	1200	480	3000	FWT	27600	6897P
GX9.5	CP/90	240	1200	240	3200	-	30000	6895P
GY9.5	CP81	240	300	180	3200	FSK	7050	6872P
GY9.5	M38	240	300	2000	2950	-	5200	6874P
GY9.5	M40	240	500	2000	2950	-	10000	6877P
GY9.5	CP82	240	500	180	3200	FRJ	13500	6873P
GY9.5	T25 (T18)	240	500	360	3000	GCW/GCJ	11000	6820P
GY9.5	T27 (T26)	240	650	600	3050	GCL/GCS	14500	6823P
GY9.5	CP89	240	650	180	3200	FRM	16250	6638P
GY16	CP/72 (CP/43)	240	2000	480	3200	FTL	50000	6994P
G22	CP68 (CP39)	240	650	120	3200	-	16500	6993Z
G22	CP71 (CP40)	240	1000	240	3200	FKJ	25000	6995Z
G22	CP92	240	2000	400	3200	-	50000	6975Z
G22	CP91	240	2500	400	3200	-	65000	6894Y
G38	CP73 (CP41)	240	2000	480	3200	FKK/FKP	50000	6994Z
G38	CP85 (CP29)	240	5000	420	3200	-	132500	6963Z
P28s	T24(T17)	240	500	900	2950		9500	6800C
P28s	T22(T13)	240	650	900	3000	FKB	12600	6998C
P28s	T20(T14)	240	1000	900	3050	FKD	21000	6996C

John Grimshaw details the hideous differences between one tungsten halogen lamp and another!

raises the position of the GKV filament to be in the same position as the HPL filament.

The difference between Strand's Patt223 and Patt743

These fixtures are almost identical – except for the type of lamp they use. The Patt223 with a P28s base uses the older design T20, whereas the Patt743 with a GX9.5 base uses the T19. As the GX9.5 base grew to dominate the 1kW fixture market, many owners of the Patt223 wanted to install a GX9.5 base. Some years ago, kits in the form of pre-drilled bits of aluminium were available to allow people to do this.

The Tungsten-halogen Life Cycle

Tungsten-halogen lamps contain a conventional tungsten filament surrounded by halogens. As the tungsten atoms vaporise from the filament, they are chemically captured by the halogen atoms and returned to the filament. Tungsten-halogen lamps are typically 50% brighter and last almost twice as long as conventional lamps. Dimming these lamps is fine, but at lower voltages the above cycle stops, causing a slow deterioration of the filament.

Bubbles, Bulbs, Lamps, Fixtures and Fittings

Bubbles, bulbs, lamps are all terms that are used to describe the source of light in a light fixture or fitting. More often than not, you will find that industry technicians use the term "bubbles" for any lamp/bulb. This is to avoid the confusion often caused by the word "Lamp". While the bubble suppliers and manufacturers use "Lamp" as a generic name, the dictionary meaning of the word can also be used to describe the whole light fixture. You could use the word "bulb". However if you do, your peers are likely to look down on you in much the same way as someone wearing thongs and a singlet to a nightclub.

Don't Touch The Glass

Anyone who has been shown properly how to change a lamp in a fixture is told, "Don't touch the glass." Skin produces an oily secretion into which all sorts of environmental dust is captured and/or dissolved. If you were to touch the glass, it is highly likely that some of this residue will be left on the glass. When power is fed to the lamp, this oil and other contaminants are burnt off, clouding the surface of the glass and changing the optical characteristics of the lamp. In extreme situations (if enough oil is present) the glass can heat at different rates, causing a fracture and subsequent blow out of the lamp. It is not uncommon to be able to see black fingerprints burned onto the surface of a lamp that has been handled by a careless worker.

>Continued over

Your 'One Stop' Rigging Shop.

At Hoisting Equipment Specialists, we have the most comprehensive range of rigging, lifting and materials handling equipment in Australia. As suppliers to the Entertainment Industry for more than 15 years, H.E.S. has the staff with the knowledge of your requirements. We understand you have deadlines and you will have peace of mind knowing your order will arrive on time, everytime. We guarantee it!

"Hoisting Equipment Specialists" the name to remember for quality, service and advice, at the right price!

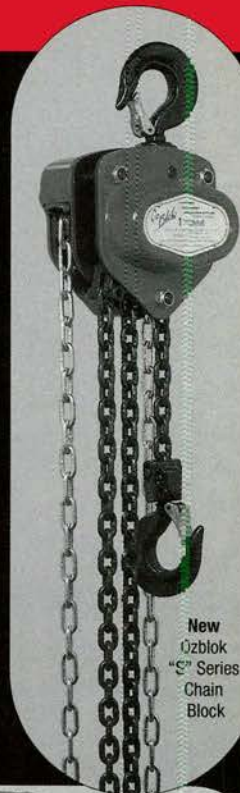

New Ozblok "S" Series Chain Block



Black Polyester Round Sling

- Ozblok range of products, including the new generation "S" Series chain blocks, girder clamps and trolleys.
- C.M. Lodestar, GIS, Kito and Hitachi chain motors.
- Galvanised and stainless steel wire rope and fittings.
- Standard wire and Superflex steels and bridles made to your requirements.
- Manual and electric winches.
- Extensive range of rigging hardware including rated shackles, rigging screws, eyebolts etc.
- Black polyester round slings.
- C.M. Stac chain.
- Height safety equipment and fall arrest systems.

OzBlok

- Industrial and recreational harnesses, carabiners, dynamic and static climbing ropes.
- Tri-lite pocket laser levels.
- Canvas chain bags.
- Bonwick caving ladders.
- Endless webbing ratchet straps and load restraint systems.
- Sisal and manilla rope.



HOISTING EQUIPMENT SPECIALISTS PTY. LTD.

12/53 Norman Street
Peakhurst NSW 2210
Phone: (02) 9584 1177
Fax: (02) 9534 1201
Email: HOISTEQUIP@bigpond.com

39 Raglan Street
Preston VIC 3072
Phone: (03) 9480 5577
Fax: (03) 9480 0855
Email: hesvic@ocean.com.au

IGNITE YOUR IMAGINATION

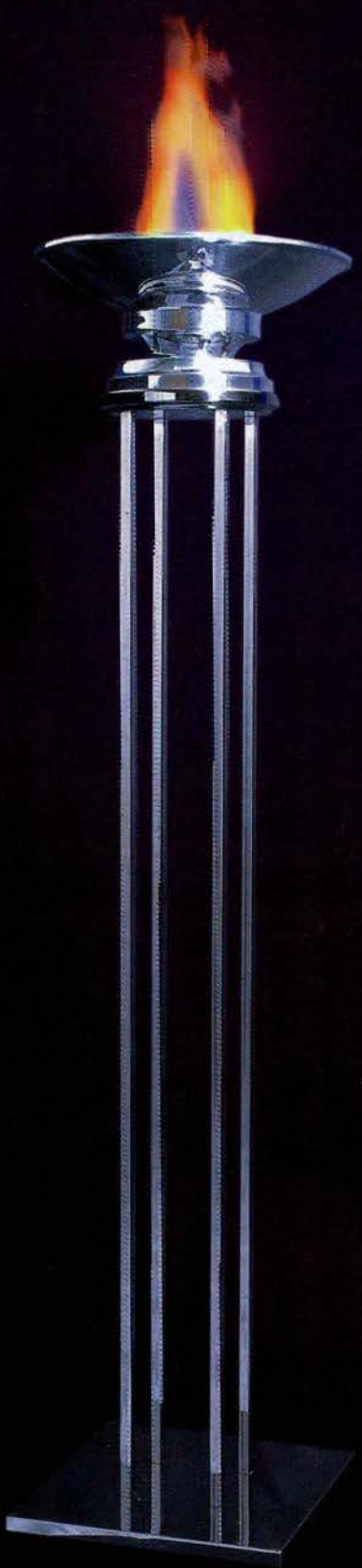

NO SMOKE - NO HEAT - NO FUMES - NO PROBLEMS

For Further Information:

08 9228 3000

unique@space.net.au
www.uniqueflamelight.com



Words From The Wise

Bob Jessor of the Odeon Theatre in Adelaide says that inexperienced casuals are the cause of blowing most lamps. He calls this effect "fuckwittery". Mr Jessor is obviously very good at looking after his lamp life. His twelve Selecon 1200 profiles have blown two lamps in four years (and a third was broken during maintenance). He has managed this impressive record by two main methods.

Firstly, he trims all of his dimmers to 230V. Apparently only one lighting designer has noticed that the dimmers were trimmed back to 230V. In Mr Jessor's experience, doing this can increase the lamp life by as much as 25%.

Secondly, he minimises as much as possible the moving of the fixtures. During a bump-out, the theatre is returned to a standard rig. The next show's lighting design is then built from this base position. As far as purchasing lamps are concerned, he always buys a year's worth of lamps at a time to get the benefits of bulk discounts and one delivery charge. •

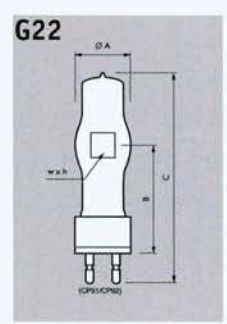

Lamp	A	B	C	W x H
CP91	40.0	90.0	175.0	20.0x21.0
CP92	40.0	90.0	175.0	14.0x13.0
CP68	22.0	63.5	140.0	11.0x12.0
CP71	28.0	63.5	140.0	15.0x13.0

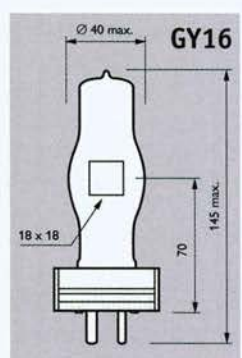

Lamp	A	B	C	W x H
CP72	40.0	70.0	145.0	18.0x18.0

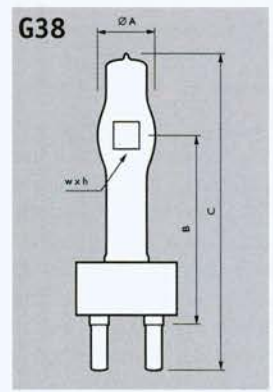

Lamp	A	B	C	W x H
CP85	62.0	165.0	280.0	26.0x29.0
CP73	40.0	127.0	210.0	18.0x18.0

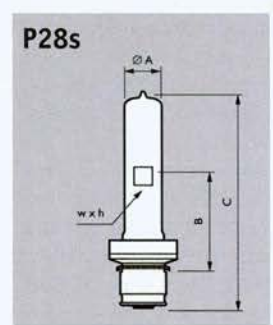

Lamp	A	B	C	W x H
T24	20.0	55.6	130.0	11.0x11.0
T20	28.0	55.6	125.0	15.0x13.0
T22	22.0	55.6	125.0	11.0x12.0

INFOCOMM ASIA

21 to 23 March 2001, Singapore

2001

- Are you in Audio-Video, Presentation, Projection, Multimedia and Interactive Conferencing business?
- Do you plan to expand into Asia, create new businesses in Australia, venture into New Zealand?
- Would you like a cost-effective Marketing/Sales/PR opportunity that will give you maximum results?
- Do you wish for ONE simple answer to ALL your questions?

Be an EXHIBITOR at **INFOCOMM ASIA 2001**

Providing Solutions Across Asia

21 to 23 March 2001, Singapore Expo

CALL US at **(65) 297 2822**, DROP A FAX **(65) 296 2670** or

Go online @ **INFOCOMM ASIA.COM**

For your booking forms; special savings; premium benefits

Organizer: **INFOCOMM ASIA Pte Ltd**

Sponsored by:



Endorsed by:



Approved International Fair

Supported by:



SINGAPORE EXHIBITION & CONVENTION BUREAU
A DIVISION OF THE SINGAPORE TOURISM BOARD

Please tick where appropriate

- Send me my booking form Call me Send me your sales kit I want to visit. Keep me updated.

Name: _____ Designation: _____

Company: _____

Address: _____

Country: _____ Postal Code: _____

Tel: _____ Fax: _____

E-mail: _____



Piaf plays big houses in bi-city run

Mandy Jones details the technology and techniques behind this Winter's best seller

Piaf is a musical dramatisation of the life of French chanteuse Edith Piaf, tracing her troubled life from her beginnings in the streets of Paris to her death in the grips of heroin addiction. The MTC production recently concluded at the Playhouse in Melbourne and is now being hosted by Sydney's Ensemble Theatre in the Foxtonbridge Theatre.

With a set designed by Dale Ferguson and lighting by Gaven Swift, the intention of the show's artistic design was to bring the action of the play closer to the audience - a cabaret club style thrust stage, a five piece band in full view of the audience, and a simple but stark set design utilising organza curtaining and a large wedge covering half the proscenium with a stylised painted image of Piaf.

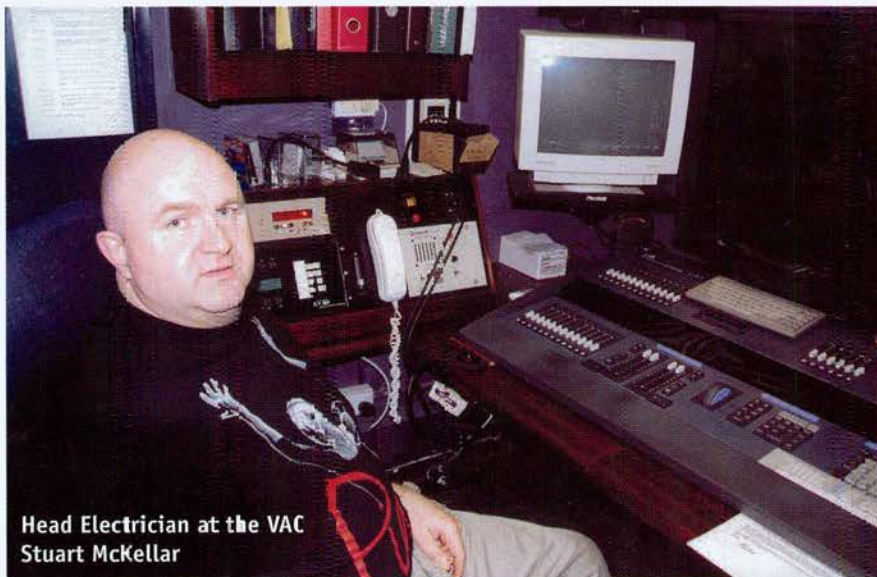

Head Electrician at the VAC
Stuart McKellar

As Head Electrician at the VAC, it is Stuart McKellar's role to operate shows performed at the complex, most recently the Melbourne season of *Piaf*.

"A typical matinee performance day, I get here at 12.30pm to do a lamp check to make sure there's no blown lamps or burnt-out colour. There's a casual followspot operator who comes in at 1.00pm so by the time he arrives I've worked out exactly what has to be done. We set the pracs, make sure they're all wired up ok because they get broken quite often, and do blackout checks to make sure all the houselights go out. After that we wait around for the half hour call, put up the preset, go to black, make sure all the worklights are happening and then the show starts.

"After the show it's a matter of turning the blue workers off, turning the lights on, waiting for the audience to leave, take the post show cue out, turn the normal workers on and bring in the fire curtain."

Interestingly, it is the policy of the VAC not to turn off the consoles or the dimmer racks at the end of the day, in fact they stay on 24 hours a day, 365 days a year.

"We found out back in the Galaxy days that we halved our maintenance costs by leaving the desks on because by constantly turning them on and off you're cooling and heating the components, but when they're on, once they get to a certain temperature unless a fan breaks down they remain at that temperature, and being an air-conditioned building it doesn't matter. We turn off the monitors for the 530 but that's it."

Stuart operated *Piaf* off the Playhouse's Strand 530 console.

"There's nothing really difficult about this show, it's a matter of pushing a button 130 odd times. 130 cues is fairly typical of shows these days. In the old days, a lot of times you would be lucky to get 60 cues in a drama. Most of them that are coming out these days are well over the 100 mark.

"Sometimes I miss faders. I actually did a show at MTC where I ended up plotting it in manual cues and I was quite happy to do that. So if anyone suggested a visual cue I was quite happy to do it because I knew I could time it perfectly. I have to disagree with LD's who say humans are not as accurate as a computer, because at least a human can feel, and if they're a good board operator they can feel the moment of the show."

The *Piaf* lighting rig was made up entirely of lighting stock from the VAC, some of it described by LD Gaven Swift as "a bit long in the tooth". In all, there were around 300

> go to 53! (Please....)



THE JANSEN (CHRISTCHURCH) STORY

By Lindsay Nelson

A shopfront very hard to miss in Christchurch is the Jansen store. Many New Zealand musicians will fondly remember their amps and musical instruments, but perhaps not so our Australian readers.

Jansen had its beginnings in Auckland in the late 1950's. Bruce Eady and Jack Collins began by repairing pianos and assembling amplifiers. They moved on to the production of organs and guitars and as the demand for guitar amps grew, they moved into the manufacture of these too.

In 1965 Jansen produced their first solid state amplifiers with names such as the PA 80, and the PA 150. These became widely used by New Zealand musicians across the country.

Jansen has phased out production, due partly to the competition from South East Asia, and now focuses on the importation of a complete range of equipment from around the globe.

The Christchurch branch Manager is Peter Urbeni. Peter trained as a Funeral Director but in his own words, was bored stiff with the job. (*Very funny. Leave the humour to Fry' - Ed*) His involvement with bands led him to a career in sound, firstly in sound hire, and more recently into recording. It was this audio connection which led him to his current position with Jansen.

'Our aim is to be a one stop shop for all professional lighting and sound products' States Peter. 'We are the South Island's only specialty PA Sales shop.'

When quizzed about his relationship with local musical Instrument retailers he responds: 'We see a clear line between music retailer and our own operation, and industry people are beginning to see the difference between us'.

The day I visited the store I was given a product line demo of some very impressive equipment. The product is beautifully presented in a spacious showroom with polished boards and loads of black and silver facias.

'Our market includes the installation industry - clubs, bars commercial install'.

Jansen has plans to launch new product lines this year, so stay tuned for some exciting news.

If you are from out of town, drop in and have a chat with Peter, he'll make you welcome!

REPUTABLE RESPECTABLE RELIABLE



Compressor/Limiters; Equalisers; Pre-Amps;
Zone Controllers; Voice Processors;
AGC Levellers; SPL Computers

Symetrix
For those who know the difference

www.audiotelx.com.au

NSW: (02) 9647 1411, VIC: (03) 9890 7477,
QLD: (07) 3852 1312, WA: (08) 9228 4222,
SA: (08) 8352 4444, NZ: (09) 415 9426



The Sabine Wireless Microphone System includes:

FBX Feedback Exterminator
Compressor/Limiter
Auto De-Esser
In Built Battery Charger
30 Channel UHF Receiver
SABINE
ADAPTIVE AUDIO

www.audiotelx.com.au

NSW: (02) 9647 1411, VIC: (03) 9890 7477,
QLD: (07) 3852 1312, WA: (08) 9228 4222,
SA: (08) 8352 4444, NZ: (09) 415 9426

units in the rig, including some rather unique moving lights driven by air rams invented by MTC's technical wizard Kerry Saxby. (See story at right for more on these!)

"For the Sydney season at the Footbridge Theatre I've had to cut a third of the groundrow, half of FOH and I still have to pair things up just to fit them into the venue," explained Gavan.

"One of the challenges of the show was the big wedge that had the painted image of Piaf on it. It's made of panels of ply joined together, so if you hit it with normal light all you would see is all the joins and flat black looks pretty terrible. So her image, which we light in red and very pale blue is actually a custom gobo made by the Gobo Factory. The gobo picks out the painted image so none of the black is ever lit." •

Water-Powered Search Lights at Piaf

While pneumatic powered motion has been used in theatre for some time for short stroke purposes (eg. door opening devices), pneumatic's limitations are shown up in fitting to theatrical requirements.

The door accelerates and closes with a bang due to the not-perfectly vertical jam or the air restrictors are wound in for a very

slow motion and air piston stick/slip occurs. Some solutions for for these remotely operated linear movement requirements include electric winches, hydraulics and air over water systems.

The Lighting Designer of Melbourne Theatre Company's production of Piaf, Gavin Swift, required a WW2 searchlight effect on the cyc.

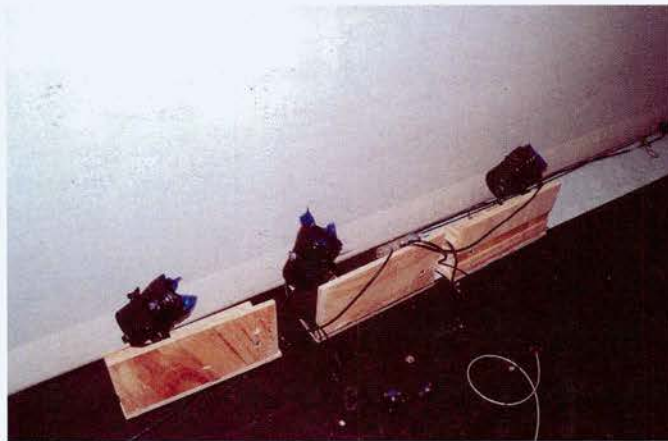

We had in stock some 12mm bore by 150mm stroke cylinders. These were attached to one end of a pivoting arm upon which (at the other end) a pin spot was fixed, allowing an arc of about 50 degrees.

The cylinders (with restrictors inline) were connected to 240v pneumatic solenoid which was driven, by a four second on, four second off chase on the

REDBACK® Audio Products
Altronics is proud to announce the following new Redback equipment...

- Four X 60W power amplifier
- Dual channel 125W power amplifier
- Dual channel 200W Hi-Fi amplifier
- Mixer amplifier with digital AM/FM tuner
- 19" Rack mount 30W PA amplifier
- 25 & 40W IP65 weatherproof horn speakers
- 24VDC Battery chargers
- Impedance matching attenuators
- AM/FM Tuner
- Programmable Alert/Evac timer
- 4" Speaker/ grill combination
- 2 way high power monitor series speakers
- ABS slim line wall mount speaker boxes
- UHF wireless microphone equipment



New Catalogue Out now!

To receive our new 260 page catalogue with over 4000 product lines, including the entire Redback range simply e-mail us at cat@altronics.com.au, or contact our head office.

A full range of product support brochures are available on request for inclusion with your quotations. For your convenience, we have established a literature request form on our web site at: www.altronics.com.au

Headquarters
Perth
Ph.: (08) 9328 2199
Fax: (08) 9328 4459

Sydney Branch
Auburn
Ph.: (02) 9648 5266
Fax: (02) 9648 5366

Melbourne Branch
Springvale
Ph.: (03) 9574 0065
Fax: (03) 9574 0075

K&M® rolls out your studio solutions

Konig & Meyer offer a range of stands, racks & trolleys to solve all your studio problems. Like the 28205 rack trolley (right) with 17 rack units down the front & 7 on top. Or the 42020 rack wagon (below) with 9 rack units in front, 12 in the tilting tray & optional add-on brackets to add another 9 rack units above the tray.



And then there's mixer stands, keyboard stands, desktop racks, music stands, all with the same legendary design integrity & build quality you've come to expect from K&M's microphone, speaker & lighting stands. Call us now for the full story.

trc

The Resource Corporation
 6 King Street Blackburn Vic 3130
 tel: (03) 9877 8233
 fax: (03) 9877 8244
 email: sales@trc.com.au

lighting desk.

In the theatre, it was found that the search light movement was too fast, even with restrictors wound in. The uneven motion was amplified by the six meter beam length. Air-over-water accumulators were inserted between the solenoid and restrictors. A very slow speed (up to five seconds full stroke) and a smooth action resulted. Because the solenoid only acts on the air side of the system, the exhaust ports can be piped away for silencing purposes.

Pros

- Smooth action and very slow speed
- Quick to assemble/disassemble due the pneumatic 'push fittings'
- Extends the use of existing air cylinder stock
- Small volume accumulators can be made from off-the-shelf pre-threaded metal pressure pipe and fittings
- Relatively inexpensive

Cons

- Water near electric wiring, solenoids
- Plastic pipes filled with water which can be punctured by sharp objects or heat sources (lanterns).

The search for smooth motion continues.

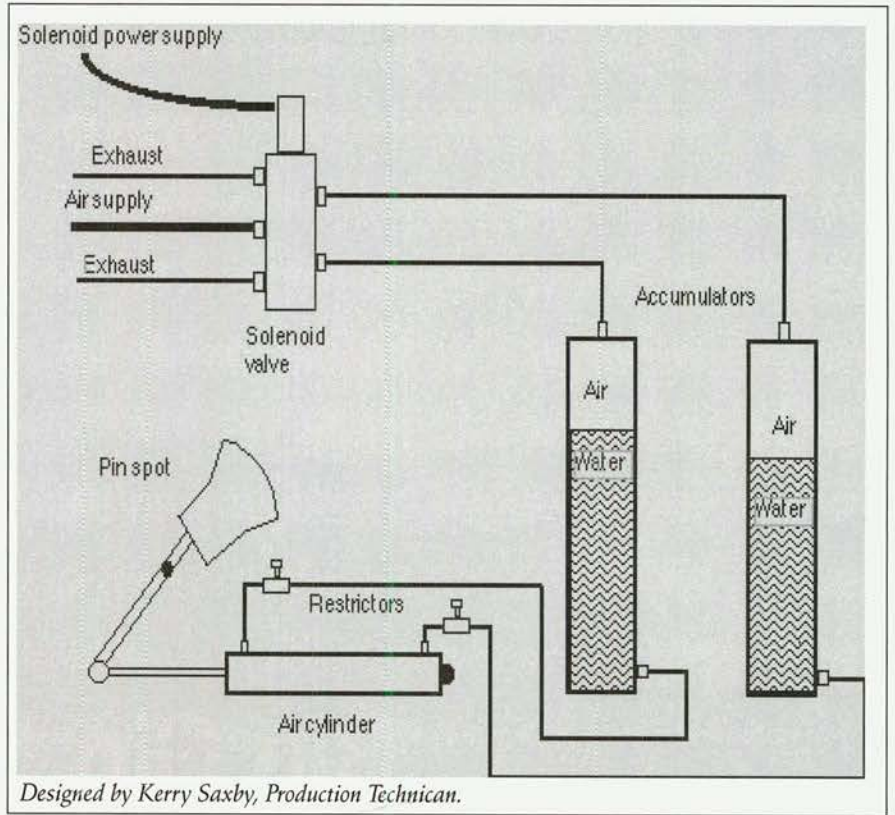

SPECIALISED LAMP SUPPLIES (VIC)

SLS CAN SUPPLY YOUR TOTAL LAMP SOLUTIONS

Wide range of quality products:

- ✓ Projection lamps
- ✓ Photographic lamps
- ✓ Theatre lamps
- ✓ CP Class
- ✓ T Class
- ✓ Par range
- ✓ MSR / MSD / MSI range
- ✓ Stage and Studio lamps

All at competitive prices

For more information

phone: 1300 302 852 email: sls@teg.com.au fax: 1300 301 329

Unit 1/37-39 Ricketts Road, Mount Waverley, Victoria 3149



Big Gig for Hyundai

TECHNICAL SPECIFICATIONS

Audio

- 8 Meyer U PA- 1 P speakers
- 4 Meyer USW sub-woofers
- 4 JBL P15 powered speakers
- 1 3300 32 ch. A & H console

Lighting

- 24 Mac 500
- 16 Mac 600
- 6 Mac 300
- 16 Futurelight Spot & washlights
- 16 Miniscar HPE
- 60 Par 64 ACL
- 2 4k Tracers
- 6 1.8k Colorados washlights
- 6 575 MSR Kaleido washlights
- 1 Echelon console
- 4 Jands Production Dimmers
- 4 Satecon Performer 1200MSR follow spots
- 3 Crackers

Over 400m of box trussing
& 36 chain motors

It's

not uncommon for a car distributor to stage a mega, massive event. Hyundai Automotive Australia are no exception- they recently launched their new range of vehicles for the new Millennium to their dealer network. Many production people were employed.

Sophisticated staging, giant screen projection, pyrotechnics, special effects lighting and an amazing display of car stunts by the Hyundai Precision Driving Team all combined to make the evening 'a night to remember'. Designed and orchestrated by Showcorp, one of Australia's leading special events companies, the performance was undertaken at the Sydney Showground's RAS Dome at Homebush Bay.

Surprise was a key element of the evening's proceedings. A carefully orchestrated program tantalized the 350 VIP guests. From the moment they arrived they were awed by the enormity and atmosphere of the RAS dome, which was enhanced by the special effects lighting. Guests were elegantly greeted with cocktails then ushered to their pre arranged seating in the center of the dome where tables were decorated in a glittering combination of blue sequined table cloths and candle adorned metallic centerpieces.

For purposes of the precision stunt driving and presentations, tables were subtly laid out

in four segments in front of an elevated stage with ramps and tunnels leading from a number of access points. A high point of the technical presentation was a giant projection screen some 30m wide plus four smaller close-up screens which were suspended in front and moved into various positions throughout the evening to highlight the large format slide projection, video and lasers.

The evening's program was organized around three car reveals with a finale surprise. Large format scrolling Pigi projection created each scene. Video images of the new Accent cars driving from a projected cityscape made way for the stunt drivers who criss-crossed through the audience. The second segment was the reveal of a new people mover which first appeared to drive across the four front screens before miraculously appearing inside the dome. As the Pigi images transformed the set into the Blue Mountains, a 4WD appeared from within a mountainous gorge and drove down a staircase. The finale brought the audience to their feet as precision drivers raced their cars nose to nose around the perimeter of the room before a new Accent Rally car came screaming out from behind the set and drove up a ramp and leaped into the air as pyrotechnics engulfed the audience.

Showcorp's Managing Director and producer of the event, Colin Baldwin,



comments: "This was a first for the venue, it required complex staging and coordination with safety being the main issue. We were delighted with the confidence expressed by our client for such an undertaking. Normally with a launch of this kind you only need to

design one major reveal component. As Hyundai was previewing a new range, our task was more challenging - to come up with three separate, unique and exciting reveal concepts that would blend into the overall theme of the event. It was an exciting and



robert juliat

CYRANO - LDI BEST PRODUCT 1999

- High Powered 2500W HMI Source
- Designed as an operator's followspot
- Precision control of fade by rotary throttle
- Variable soft glass beam softener
- Centrally mounted 6 way colour changer

Available from

EMAIL - bytecraft@bytecraft.com.au WEBSITE - <http://www.bytecraft.com.au>
 VIC - 23-31 Fonceca Street Mordialloc 3195 Tel: 03 9587 2555 Fax: 03 9580 7690
 NSW - 5/31 Bridge Road Stanmore 2048 Tel: 02 9550 3555 Fax: 02 9519 3977



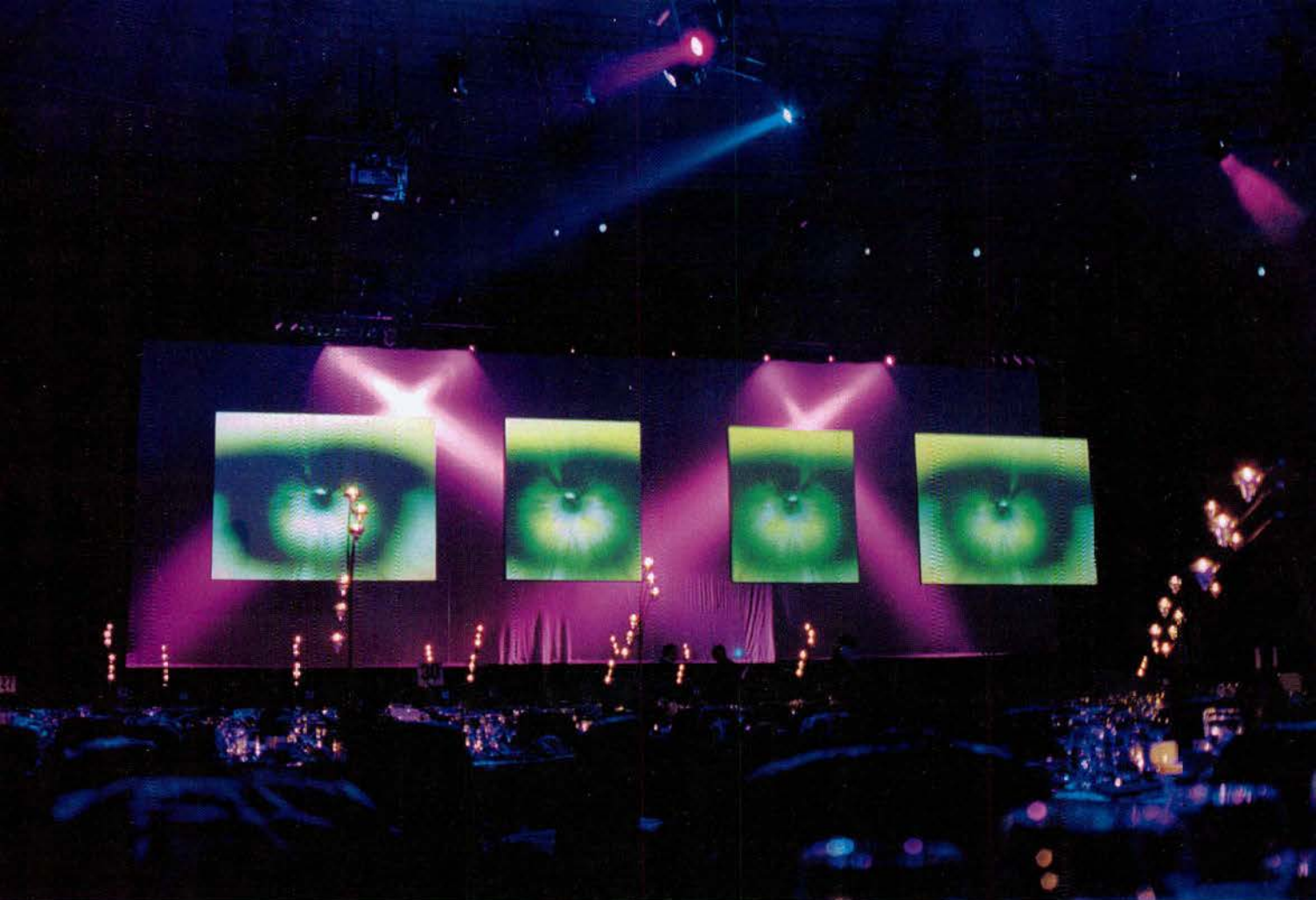

AON Risk Services
presents

Entertainment Protection Plus

INSURANCE FOR ALL YOUR ENTERTAINMENT RISKS

- Equipment
- Travel
- Non appearance
- Cancellation or abandonment
- Public liability
- Personal accident
- Vehicles
- Workers' Compensation

Email: ken.killen@aon.com.au

Call Ken Killen or Ian Stack
TOLL FREE 1800 806 584
for free quotations & advice

Level 27, AON Tower, 201 Kent Street, SYDNEY, 2000 Tel (02) 9253 7570

interlink@ocia.com.au : 1800 638 777

INTERLINK
SYSTEM SOLUTIONS

1201, 12" & Horn Speaker

\$849 / pair

- + 200 w RMS, 400 w programme
- + Stacking corners
- + Dual Speakon connections
- + Integral stand mount
- + Durable black carpet finish
- + Recessed handle

Stands not included, \$149 / pair
Prices exclude tax and are valid until 30 July 2000

1201



very successful evening for all involved".

The Hyundai launch was part of a four-day dealer program. Showcorp coordinated all events for Hyundai over this period, involving a harbour cruise to Taronga Zoo and business session in the Zoo's theatre; a test drive into the Kuring-Gai National Park and a themed dinner at the Star City Ballroom with entertainment by Marcia Hines, the magnificent hypnotist Martin St James and special guest star Steve Waugh, Australian cricketing legend. The culmination of the event was a Gala Dinner in a clear skinned marquee overlooking the Opera House from Bennelong lawn. A performance by Rob Guest and stunning finale fireworks display on Sydney Harbour, truly branded Showcorp's Hyundai 2000 Dealer Conference as an event program of sensational impact.

Hyundai 2000 Specifications

Video

- 1 30m x 10m custom screen
- 4 6m x 4m custom screens
- 1 Digital Projection 5GV video projector
- 4 Sony X2000 vidc projectors
- 3 Panasonic MX50 digital vision switchers
- 3 Sony DSC 1024 scan converters
- 1 Shirley Spectra video server

Large Format Projection

- 2 7k ETC Pigi projectors
- 1 4k Xenon hardware projector
- 1 ETC software controller

Laser

- 1 20w Agron laser
- 1 Sinodial Data Pump

Pyro

- 4 Line rockets
- 8 Silver Air Burst
- 12 Short Spark Shower
- 3 Large Red Flame
- 12 Large Flash Pot
- 12 9m Silver Jet
- 24 Silver Mini Mines

Pollards provided the rigging, TDC the video components, The Electric Canvas did the slides, Howard & Sons the pyro, Laservision on lasers, Edwin Shirley Staging and Showcorp did the sound, video images and lights with a little help from LOW, Scott Polkinghorn and Electric Sunshine.

Event Management & Crew

Colin Baldwin	Producer
Peter Milne	Technical Director
Paul Venables	Event Coordinator
Sarah Ploughmar	Event Coordinator
Sarah Stinson	Production Assistant
Maggie McKinney	Production Assistant
Wane Jarvis	Production Manager
Alan Stone	Lighting Director & Operator
Jamie Klein	Lighting Technician
Matt Fordham	Lighting Technician
Gary Hall	Audio Engineer
Des O'Neill	Audio Systems Engineer
Steve Mackay	Rigger 1 Staging Operator
Michael Rampe	Video Camera
Lloyd Weir	Laser Operator
Steve McMahon	Laser Operator
Dale Lewis	Communications
Christian Howard	Pyro Operator
Humphrey Deahnan	Pyro Technician
Greg Fletcher	Pyro Technician
Stuart Bensley	Pyro Technician
Damian Negus	Stage Manager
Michael Miller	Stage Manager
Tim Campbell	Safety Marshall
Paul Geurin	Safety Marshall
Ray Walsh	Staging Carpenter
Terry Lucas	Staging Carpenter

Plus 12 stunt drivers and 20 loaders from Australian Crewing

World's easiest subscriptions!

Au \$52 1 yr*
 Au \$86 2 yrs*
NEW ZEALAND:
 Au \$80 1 yr
 Au \$120 2 yrs
ASIA:
 Au \$80 1 yr
 Au \$140 2 yrs
USA:
 Au \$115 1 yr
 Au \$199 2 yr
EURO:
 Au \$125 1 yr
 Au \$240 2 yr

- Step one. Decide to save 25% or more.
- Step two. You want your mag early, before the newsagent.
- Step three. You know we are very trusted to do this right!

3 VERY EASY WAYS TO SUBSCRIBE:

- (A) Use our online form at www.conpub.com.au ; or -
- (B) Just Call Sarah on 1-800-635-514 in business hours.

*Price includes GST

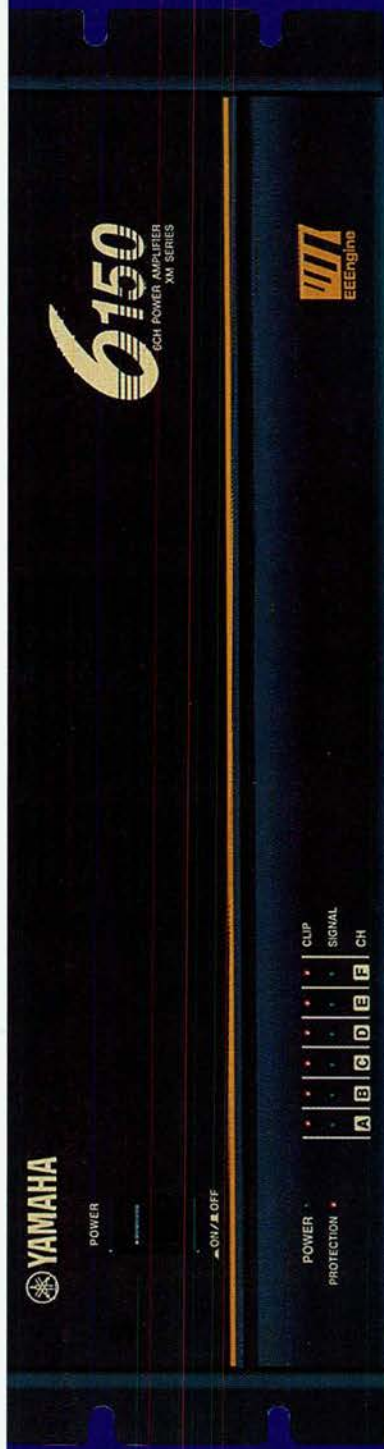

XM6150 ÷ 3U = 6 X 150W RMS @ 4 Ω + HPF

- XLR & Euro-block inputs
- Binding post outputs
- Amps bridgeable in pairs
- Precision rear attenuators
- Individual high pass filters (switchable)
- Variable speed fans
- Individual amp status indicators
- 18 Kilograms



PO Box 268, South Melbourne Vic 3205
 Toll Free 1800 805 413 Fax: 03 9696 4579

Web Sites: www.yamaha.co.uk
www.yamaha.com/proaudio www.audio-technica.com

By John Grimshaw



Despina Dimmick (*aka Dee*) is the creator and owner behind the very successful crewing company, "All Access Crewing". This company has grown from nothing to now being recognised as one of the main crewing services in Brisbane - and it is still growing.

Dee, a mother of five children, may not have realised the full implications involved in starting her new business, but she had the strength of will to see it through to where it is today.

Understanding how this company came into being gives a keen insight into how Dee herself likes to operate. In 1995, after Dee's husband was employed by the Brisbane Entertainment Centre, she began to see a need for a crewing company that gave its workers more than just the minimum required Workcover, tax and superannuation payments (and even this was lacking in some cases). Dee was interested in starting a crewing service that fostered and developed skills amongst her employees, as well as creating a "family" type of atmosphere for good morale. The intention was to create a crew that enjoyed the work and were good at it.

Initially, the going was hard for her new business, as it seemed to her that others were trying to squeeze her out. It is Dee's understanding that in some of these cases, these attacks were based on the fact that there was a woman moving into what has traditionally been a male dominated area. She struggled to make her business survive until a chance meeting with Paul Dainty that was arranged by a mutual friend.

By the end of this meeting, *All Access Crewing* had scored the crewing contract for the Brisbane leg of U2's "Pop Mart" tour. Dee alleges that at the time, this contract also resulted in some of the worst threats to her and her company by other companies. Even family members were asking if it was all really worth the effort. These were tough times for Dee, but in the end, her tenacious attitude won out. *All Access Crewing* supplied more than 250 crew for the Queensland leg of the U2 tour.

After this, things became a little easier for the

company, but there still remains that lingering resistance from the occasional Production Manager to a female running a crewing company. It is likely that in her case this issue has only been circumnavigated by the growing reputation of her company.

These days, *All Access Crewing* has a core staff of around 50 workers, with a further 300 on Dee's database waiting for work and the company is moving from strength to strength. Careful organisation is required for supplying the right crew for the job - a crew that arrive on time, ready to work, and carrying the right tools. As the public face of her company is worn by the crew that work for her, it is not unsurprising that Dee goes to great lengths to get and look after her crew.

At the same time, she intends to continue to encourage and train new crew. It has been apparent to Dee that for a long time, old crew were very careful about teaching skills to new crew. This was because there was a prevailing feeling that this knowledge could ultimately take what few jobs there were in the industry away from them.

On this subject, Dee's view is similar to the one shared by many technical managers around the country - that crew should be given every opportunity to learn, refine and define their skills. An intelligent crew is an important asset - especially to a crewing company.

Not content with simply waiting for contracts to be offered, in the next few years Dee would like to include production management into her company's profile. Perhaps this is another way to bypass the perceived gender imbalance in Dee's end of the industry. In any case, this step would stretch her organisation skills to the next level, a step that is well within the capabilities of this very successful woman.

So what is Dee's key to a successful entrepreneurial business? Good Morale.

Going to work should be like getting together with family - and everyone should go home satisfied with a good day's work.

Micrommlaser

P.O Box 1447
Sydney 1765
NSW Australia
Tel. +61 2 88503945
Mobile + 61 410429822
E-mail info@micrommlaser.com
www.micrommlaser.com

Laser Entertainment & Advertising Systems

WORLDS FINEST!
Award Winning Features.
Super Bright Miniature Lasers.
Affordable Technology.

RETAIL
ANNOUNCE EVENTS
EXHIBITIONS
DISPLAY MESSAGES
TRADE FAIRS
PROMOTE YOUR PRODUCTS
BILLBOARDS
EYECATCHING ADVERTISEMENTS
ENTERTAINMENT
ENJOY WORLD CLASS LASER SHOWS

With Tiny Good

Rigging Note No.6: Truss

This is all about the most used and misunderstood piece of equipment in the industry.

Firstly here are a few lies about truss. Just throw it in the truck it is only truss. Tighten the bolts really tight it makes it stronger. 12 metres is as far as you can span between points. And last but not least - we just need a bit of truss to hang some lights on, not much though!

So now the truth. A truss is a fabricated steel or aluminium structure that has been designed and checked by an engineer to support the load of equipment and spread that load over a number of points. Each type of truss has a load data sheet produced for it and these are available from the truss manufacturer or retailer. The load data sheets will tell you how much weight a type of truss will support over a given span.

The data is usually in 2 basic forms a center point load chart, which is the load applied in the center of the span, and a UDL (uniformly distributed load) which is a weight per metre applied over the whole span.

The span is the distance between the points (motors, blocks, winch ups, etc.) -and this does not include overhang or canter lever past the points.

A truss, and indeed all rigging, must be selected with the whole system in mind. You can not just decide on a rig that looks good and then tell the sound and light people to go for it. The load of the equipment and the capability of the venues must be considered when selecting the trusses for a rig.

Some basic rules for truss (all truss)

- Check the load on the truss against the data sheets
- Treat it with care, it is holding your lives in mid air, whether you are on it or under it.
- Don't over tighten the bolts, firm is fine.
- Do not use power tools to tighten bolts it will damage the truss and the bolts
- Do not let forklifts near your truss unless it is on pallets or dollies, I have seen more truss bent with forklifts than any other reason.
- Do not let it travel on the checker plate floor of a truck, ply or carpet will stop it wearing and damaging the material, this applies to steel truss as well!

The constructions of trusses differ for many reasons, form spans and transport, to copyright and personal preference. You should never assume that because two trusses look similar that they are capable of the same ratings, construction and material grades can vastly affect the capacity of a truss. Check the datasheet when you are working with an unfamiliar truss type.

The information contained in this note is the opinion of Tiny Good based on industrial training as a rigger, and job experience. No liability is accepted for use or misuse of this information.

Staging CAN'T get any easier than this...

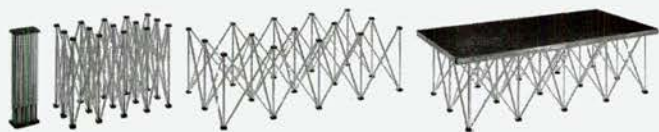

2m² of staging set up in 30 seconds by one person. Sound good? Then also consider these points:

- Lightweight – one 60cm tall leg section weighs only 5kg
- Strong – will support 1000kg per m²
- Fast & easy to set up – the leg section can be set up with one hand!
- Versatile – multiple heights let you build steps, multi-level staging, in fact you are only limited by your imagination!

SC Systems - distributed in Australia by:

The Resource Corporation Pty Ltd

trc

tel: (03) 9877 8233

fax: (03) 9877 8244

email: sales@trc.com.au

How's it hanging?

OmniMount Systems, the world's premier manufacturer of speaker mounting systems for consumers & audio/video professionals announces the launch of its new, revolutionary, **ARC** TV mounting system. OmniMount's futuristic **ARC** is a fully adjustable framing support system designed to mount monitors of all sizes in a safe, simple and stylish manner.

- ✓ **2 Design & Engineering Awards**
- ✓ **Slide together frame**
- ✓ **No shelf or hold-down straps required.**



When mated with OmniMount's proprietary, rugged ball and clamp assembly, **ARC** can hold virtually any TV monitor, including the largest 40" direct view and flat screen plasma displays.

Seamless in appearance and thoroughly engineered, the **ARC** creatively and powerfully sets a new standard in mounting systems.

OMNIMOUNT®
S Y S T E M S

Australian Distributor: Designer Sound Ph: (03) 9876 2333

Fax: (03) 9876 2033 www.ozemail.com.au/~hcaudio

PRODUCTION SERVICES

IT'S ALL,
A QUESTION OF TIME!

"Laboratory Series Technology"

LS7



2.5Kw RMS,
2 box system,
30hz to 20Khz
2x18", 2x12", 1x2"!

PLUS

LS1 L/T: 900 watts,
long throw mid high!
2x12", 1x2"!
LS1 U: 500 watts,
2 way underhang
front fill!
1x12", 1x2"!

**CLUBS TO STADIA
THE TOTAL
SOUND SOLUTION!**

**HIGH IMPACT,
HIGH DEFINITION,
SOUND REINFORCEMENT!**

**CHECK OUT THE REST OF
OUR L.S.T. RANGE**

**PLUS OUR SP AND
SPECTRE SERIES AND OUR
LS POWER AMPLIFIERS!**

*"Laboratory Series Technology
redefining the science of
acoustic technology!"*

Production Services

10, Melton Enterprise Park,
Brickyard Lane, Melton, Brough,
East Yorkshire, U.K.
rocky@proservs.freeserve.co.uk

Venue Audio

COLONIAL STADIUM THE PA WORKS AS PLANNED!



Australia's newest arena, the Colonial Stadium in Melbourne, boasts one of the most comprehensive PA systems in the country.

Jennifer Temm speaks to the design team behind it.

Melbourne's new 55,000 seat Colonial Stadium posed a unique set of problems for the design team behind the sound system. Time limitations, a tight budget and placement difficulties called for a great deal of ingenuity.

"Time was a significant issue," said Chris Dodds, managing director of PA system subcontractor, The PA People. "For a building like this we would normally have 12 to 18 months from order to delivery but we only had six months from the time the sound system design was accepted to when we had to turn it on - that's not long in terms of being able to commit to a design, analyse it, procure the equipment, do the custom engineering and install it."

The PA People decided on a consultative approach, hiring Glenn Leembruggen of Arup Acoustics with whom they had

previously worked on the acclaimed St Mary's Cathedral project, with additional input from Peter Grisard and Peter Twartz of equipment supplier Jands Electronics.

Applying some thinking from first principles and JBL's EASE modeling software, the team came up with a custom system which maximised the design within the budget through clever engineering.

The result is one of only two contemporary level sound systems in the country - the other being Stadium Australia, another PA People project - and reflects attention to detail in three aspects: design at a system level of radiation control and direct field optimisation, design at the component level of the crossovers, and careful optimisation of the performance during commissioning by extensive measurement and listening.

One of the first design problems the team had to contend with was the oval shape of the stadium and the square grid where the speakers could be located.

"It really posed a unique set of problems because of the inconsistent speaker to listener distance," Dodds explained. "In the corners where the square gets close to the circle, the speaker-listener distance becomes very close. We had to mount the corner clusters on the leading edge of the roof rather than from the gantry to maintain the correct angles."

"Late arrivals from the loudspeakers is one of the issues that plagues stadiums, primarily at bass and low midrange frequencies," Leembruggen added. "The orientation of the subwoofer and low-mid cabinets is designed to minimise this."

"We used the JBL 2352 high frequency horn which is much larger than you find in off-the-shelf boxes because its size produces great pattern control down to 1kHz, where it crosses to the mid range horn. We selected a midrange with a similar radiation pattern, and married them with a JBL subwoofer enclosure."

The design provides very strong pattern control and clarity in the 500Hz region which Leembruggen says is extremely critical to speech intelligibility and yet is often overlooked by designers and consultants. Weight restrictions demanded the components be rehoused in an open steel frame but this provided added flexibility. It allowed the choice of a larger mid-high frequency flare, and the unusual placement of the purpose-designed passive crossovers.

"A venue like this would normally have an active crossover between all the components but we actually used a high powered fourth-order passive crossover between the mids and highs because that meant we could effectively save 44 amplifier channels," Dodds said.

"To do that of course, we had to design a sophisticated passive crossover that you wouldn't normally find in these kind of situations, but it meant that we were able to deliver the same quality for a lower price - just more effort".

"The way we implemented it was also unusual. Because of the space frame enclosures, we were able to put the crossover with the amplifier for maintenance and waterproofing. We actually come straight out of the amplifier into the passive crossover, and run separate speaker cables to the mid and high frequency enclosures."

While the passive crossover between the mid and high frequency sections were designed in the laboratory, the active crossover frequencies and rates were chosen on site using MLSSA measurements.

"Sometimes the best crossover transitions are obtained using different high and low pass frequencies and roll off rates," Leembruggen said. "While text-book crossover theory assumes perfect loudspeakers, the different phase and amplitude responses of real-world high and low frequency drivers means that better performance can be obtained using non-standard crossover filters."

To assist installation the PA People made a winch system that clips onto either side of the catwalk so the speakers could be raised and lowered easily for easy servicing.

The main front of house system comprises 44 custom designed speaker clusters and 48 delay cabinets, with the main clusters consisting of JBL SP218 dual 18-inch sub cabinets, an OEM version of JBL's Venue Series 10-inch mid-range horns, and JBL 2352 high frequency horns fitted with JBL 2447 neodymium drivers.

"This is our first major venue where we have used JBL loudspeaker components and we are very happy with the results," Dodds noted.

The system is powered by more than 120 Crown CT and MA series amplifiers, each fitted with a Crown USP2 digital signal processing module. Paging control is provided by Crown's new USM 810 mixers coupled to an AMX system, with a Soundcraft Spirit LX32 for front of house mixing.

"We choose to use Crown amplifiers and control systems and have done so for a long time," Dodds said. "They're definitely the best and most appropriate amplifier and control system."

SELECON

PERFORMANCE LIGHTING COLUMN



OUTSTANDING

Selecon's unique 175mm **1200 High Performance PC** combines the beam precision of a zoomspot with the versatility of a Fresnel, "like a profile beam with 1/4 Harburg Frost".

Outstanding light output, beam quality and range of angles due to the custom designed lens.

The very narrow spot angle of 4° provides the output and control for dramatic highlights, while the flood angle of 60° provides a wide, well-controlled beam with even light distribution.

Useful working distances can vary from as little as 4m in spot focus up to 17m in flood focus, making it ideal for any number of lighting applications.

Top performance from a luminaire which is easy to use, simple to maintain, safe and affordable! Contact your local dealer for further information and samples to trial in your school, theatre or studio.

CONTACT YOUR SELECON DEALER OR SELECON FOR FULL DETAILS

NSW — HERKES PRO LIGHTING, Ph 02-9319 3133, Fax 02-9319 0204
VIC — CLEARLIGHT SHOWS PTY, Ph 03-9553 1688, Fax 03-9553 4401
SA — OSMOND ELECTRONICS, Ph 08-8410 1111, Fax 08-8410 3322
QLD — THE PRODUCTION SHOP, Ph 07-3216 1340, Fax 07-3216 1376
ACT — SOUND ADVISCS, Ph 02-6280 8777, Fax 02-6280 8177
WA — PRO DESIGN LIGHTING, Ph 08-9409 8964, Fax 08-9309 2541
TAS — K.W. McCULLOCH, Ph 03-6343 1034, Fax 03-6343 1847

SELECON AUSTRALIA — Ph/Fax 02-9664 8237
E-MAIL: seleconaus@ozemail.com.au HOME PAGE: www.seleconlight.com

THINGS THE BOOKS DON'T TELL YOU - 3

Painted scenery is so rare these days that the technique of lighting it is being lost. I was lucky to learn from two master set designers and painters during my time at Boston Opera, Herbert Senn and Helen Pond. On numerous occasions I had to touch the cloths or flats to reassure myself that the mouldings and relief weren't real. When such care has been taken to paint light, shade and colour, it's arrogant of a lighting designer to think his or her work can make improvements.

People are probably less confident about colour than about any other aspect of lighting design. Certainly it takes time to learn the enormous ranges, to identify how one tint really differs from it's neighbour and to understand the difference between looking at the swatch and projecting the real thing. But don't be fooled into thinking that experienced designers have all this at their fingertips! Most designers have a favourite palette and experiment with new colours as they need them.

Analyse the colours you have used and compare new ones against them, what does the new colour do the old one didn't? Is it warmer, colder, stronger, weaker? What are you looking for? However, this process needs great care, viewing the swatch against ordinary incandescent room lights, or through torches, can be misleading because neither of these operates at the colour temperature of the spotlight lamp.

On set models and costume samples try to use low voltage dichroics, or 650w spots, and try to rig them with a dimmer, not forgetting that the effect of the colour changes as the lamp filament turns redder at the lower intensities. This is why it's hard to get a good low intensity blue.

I think there's a difference between genuinely trying a colour out so that you can see what it does, and making such an esoteric choice that you convince yourself it must work either because you spent so much time on its selection (or

because you've used some very rare colours).

Sod's Law being what it is, if you put a new colour into a lamp that is hard to get to, then it's certain it won't work and you'll need to change it later.

For those who can afford them, colour scrollers offer the designer a wider palette from a smaller rig, plus the opportunity to experiment, by adding new colours to those already familiar. It is sometimes assumed that the lamp has to be dead for the scroller to move but this is not so, many a sunset effect, or mood change, has been affected by a slow moving scroller, provided that the adjacent colours are planned well in advance.

Some people split the scroller rig into two groups so that one can always be used whilst the other is changing. The use of colour is a matter of contrast, pale against strong, warm against cold. If one scene needs to be colourful, use muted colours before it, and vice versa.

With scrollers it's easy to run through colours you hadn't intended to use for a specific scene, just to see what happens. Some of the best effects are happy accidents, and scroll slowly so that you can see the effect of two colours in the same frame.

Normally of course each spot has just one colour in the frame at once, but it's important to know the effect produced by different optical systems when several pieces of colour are placed side by side in the same frame.

Basically, profile spots will blend the colour so that one is indistinguishable from the other and the largest piece will predominate (but effectively there is little value in doing this). Fresnels, by comparison, will project the colours as they are in

The Next Generation In Rental Management Software

HIRE TRACK
Eclipse

- Multi Currency
- Multi Site
- Multi User

NAVIGATOR SYSTEMS
+44 (0) 7000 628797
info@navigator.co.uk
www.navigator.co.uk

For Win95/98/2000/NT.

Eclipse
Job
Hire
Warehouse
Equipment
Diary
Planner
Multi-site
Addons

the frame, but still with a softish edge, so this is a good technique to grade colour across skies and scenery with a small rig.

The effect of profiles changes when a gobo is placed in the gate, although the result depends on whether the gobos is focussed hard (in which case the 'split' colours will make little difference) or out of focus, in which case each colour will be visible and add texture.

Don't forget the colour will have a dramatic effect on the costumes and set. The most famous exponent of this was perhaps Adrian Samoiloff who, in the 1920's in the UK, demonstrated how pure colour projected onto coloured costumes, scenery and make-up could cause different patterns to be revealed. So successful was he that this technique is now known as the 'Samoiloff' effect.

Painted scenery is so rare these days that the technique of lighting it is being lost. I was lucky to learn from two master set designers and painters during my time at Boston Opera, Herbert Senn and Helen Pond. On numerous occasions I had to touch the cloths or flats to reassure myself that the mouldings and relief weren't real. When such care has been taken to paint light, shade and colour, it's arrogant of a lighting designer to think his or her work can make improvements. In these circumstances very gentle and sympathetic illumination is all that is required. Painted scenery is often associated with pantomime, ballet and opera and in all these cases the set forms part of a repertoire and may be stored for long periods before

being used again.

The consequences of a long series of such treatment is that permanent creases form in the cloths and it's up to the lighting designer to light them out. The trick here is to hit the surface square on, so that no shadows can form. Almost always this means from front-of-house (typically from the dress circle rail or the equivalent) rather than from overhead and very soft focussed gobos with colours complementary to those in the paint can work wonders.

Much of this is scientific and so far few designers have been able to bend the laws of physics, so it's useful to know about colour theory, especially about the way light adds together, the effect of mixing the complementaries, and the result of all this on pigment. But whilst I think the science of colour is important, the final choice should be made more from the emotions than from technical analysis. Some years ago a good lighting tutor asked me what my theory of colour was, I rather flippantly replied "If it works, I leaving it in!".

Herbert Senn and Helen Pond's set design, and stunning scene painting, for 'Don Pasquale', lighting by the author. (PHOTO OCB)



MODULAR STAGE BOXES

Need a custom stage box, rack panel, patch panel or distribution box, but just can't find one?

Then look no further than MSB, the modular system that allows the assembly of the most complex panels in minutes.

Oh, and you can leave the tool box at home as this is the only assembly tool you'll need.

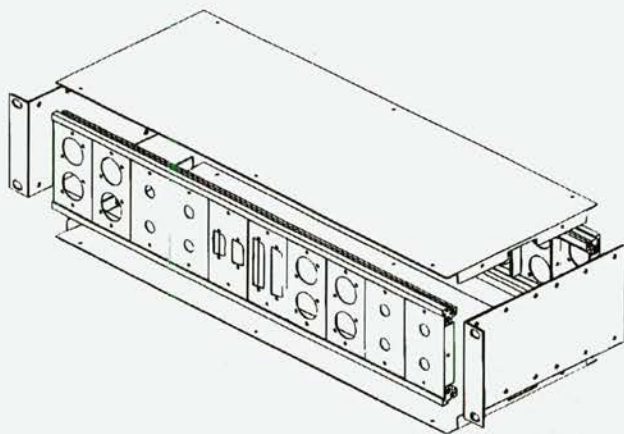

For a free catalogue, please call...

Penn Fabrication Pty Ltd

Ph: (03) 9335 6455

Fax: (03) 9335 6466

Signal Processors

(Part 1, Extract 27)



Hard Knee/Soft Knee

This phrase refers to the action of the compressor at the threshold point. Hard knee means that the compressor waits until the signal actually reaches the threshold point before any squeezing occurs. Soft knee means that the compressor starts to come in just a few dB before the Threshold and rolls over into compression gently. The idea is that the 'soft' start to the compression makes it less audible.

This is fine when using the compressor as a desk insert on vocals, instruments etc, but when you are using one as an overall system protector you want the maximum power output before any compression or limiting takes place. For this application choose Hard knee.

It's not surprising that a lot of engineers call the soft knee setting 'the support band switch!'

'Signal processor' is the generic name given to devices that modify the dynamics, of the original audio signal, unlike an effect, which is an external signal mixed in with the original. The most common signal processors are compressors, limiters, noise gates, and other devices like an Aural exciter.

Compressors and Limiters

Here's a couple of technical definitions first. A compressor is a variable gain amplifier whose output voltage compared to its input voltage decreases as its input level increases past a set threshold.

A limiter is essentially a compressor with a high compression ratio, thus maintaining a constant output level despite any increase in input level above the threshold.

So, let's look at this in non-technical terms. Basically what these do is keep an eye (or should that be ear?) on signal levels, stopping them from getting any louder than the level you set (the Threshold). A compressor puts a gentle 1 'squeeze' on excess level, whereas a limiter hits it on the head with a hammer!

Compressor Controls

The basic 3 controls that are common to all compressor/ limiters are these:

Threshold

This control varies the level at which the compressor will start to modify the signal dynamics. As soon as the signal reaches this Threshold, it is prevented from going further. The extra level that the signal would have reached is 'squeezed' up until the signal level drops again.

Ratio

This determines how much the signal is squeezed up once the Threshold is reached. It is usually variable from no compression (1:1), soft compression (2:1 or 3:1), medium compression (3:1 to 6:1), heavy compression (6:1 to 8:1) hard limiting (10:1 to XXXXX:1).

Output

This controls the output gain of the compres-

or. For example, with a low threshold and a 10:1 ratio, a lot of overall volume can be lost. The output control is a gain recovery stage, and enables you to bring back the lost volume safely (*in theory* - read 'Using the Output Control' further on in this chapter) without having to worry about any peaks that may cause distortion.

Other controls can include:

Attack and Release

These control how fast the compressor reacts to the signal increase (Attack) and how quickly it returns to normal (Release). If there are no controls for these, then the Attack and Release are either fixed, or else they vary automatically with the type of program material.

Separate Compressor and Peak Limiter

The first lets you set up a soft compression ratio to pull the mix together, and the second lets you set an absolute peak level control.

Master/Slave configuration, or Stereo Link
When running stereo, both channels (or both units, if using 2 mono units) can be controlled by the one channel or unit. Thus if the Left channel squeezes up, the Right will as well. This keeps the stereo image centred and not jumping from side to side, as it could if the two were not linked.

Noise Gate

Some compressor/limiters have a Noise Gate included on each channel. The Threshold of this can be set at just above the system noise level, to keep buzzes, hiss etc out of the system when nothing is playing.

Input level control

This allows the unit to accept a wider range of signals, from guitar pickup to professional console levels. If the control is calibrated in dB, then 0dB would be a good place to start. Set the Output the same. If the control is just calibrated 0 to 10, then set it at about 2 o'clock to start with. Set the Threshold at 0dB. Play a tape and adjust the Input level until the first LED of the Gain Reduction/Compression lights up. Now you're close to 0dB Input level.

EXTRACTED FROM DUNCAN FRY'S BEST SELLING BOOK, 'LIVE SOUND MIXING'.

©Duncan Fry 1998.
ISBN 0 646 11235 X.
Retail price A\$39.

Available from book stores and music shops around the world, or from the Connections Shop, call 1-800-635-514.

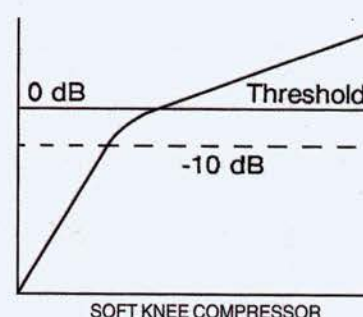
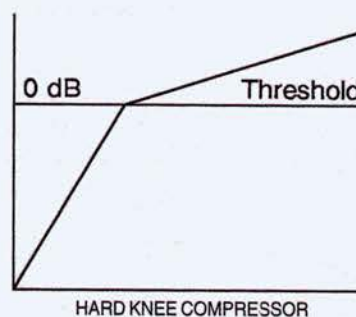



Slava's Snowshow

By Mandy Jones

Slava Polunin has been described as the greatest of all modern clowns. Combining the elements of comedy and tragedy, Slava's "alternative contemporary" style of clowning is simple, poignant and cathartic. Born in Russia in 1950, Slava was greatly influenced by the ultimate 20th century clown figures - Charlie Chaplin, Marcel Marceau and Laurel and Hardy.

Slava's Snowshow is a two hour journey into a different world. From the moment you walk into the theatre you see small strips of white paper littered on the dark carpet. As you move further in, the carpet becomes white from the piles of paper that have collected from previous performances. This snow effect is what the show is about. Slava transforms a typical theatre into a snowfield - interval becomes a snowfight between the audience and the clowns, and at the end is the terrifying climax - the snowstorm.

Slava's Snow Show

Even after the show has finished, it continues. The audience linger to engage in snowfights with the clowns and each other; and three enormous balloon balls - the largest about 5 metres high - are passed around the heads of the audience like a beachball at the cricket.

The show itself is a series of tragi-comic moments, each with Slava as the main focus. Slava's gift is his ability to direct an entire audience's attention to a single point on the stage to watch for the smallest of movements. It's not whizz-bang trickery like a Copperfield show, it's small and intricate illusions that happen so quickly you are left wondering what exactly happened, let alone how.



Richard Martin, Technical Director of the Australian tour says *Slava's Snowshow* is deceptively simple. Playing at the Comedy Theatre in Melbourne and Sydney's Lyric Theatre at Star City, the show relies on simple technology combined with ingenious creativity and timing.

"The way Slava has put the show together and created illusions with such simple things, it's complicated in a visual sense but not so much in a technical sense. The way the blizzard happens at the end of the show is quite straightforward really - a wind machine blowing lots of little pieces of paper into the audience while they are blinded by molefays. When you think about the components involved it's pretty simple, but put it all together with the music and Slava, and it's quite an amazing effect.

"Actually, the snowstorm is one of the big secrets of the show, and we generally don't tell people what makes it happen, but obviously technical people know it's a wind machine and six banks of Molefay 8-lite DWEs."

Richard's company Martin Production supplied technical management for the tour which included organising lighting and audio hire and a crew of twenty. Chameleon Touring Systems were chosen as suppliers of the lighting equipment and some of the special effects, and System Sound for the audio requirements.

Considering the spectacular effects achieved, the lighting rig is distinctly low-end. The entirely analogue rig predominantly featuring Altman Shakespeare's of varying beam angles is supplemented by Castor and



Elena, Elizaveta and Roman

Slava's Snow Show

Selecon fresnels, 36 par 64's, and two Altman Explorer 1200s run from the dress circle.

Lighting Operator Elizaveta Titanian explained the design has developed over the years and changes depending on the operator. Speaking through Slava's wife Elena who acted as translator from Russian to English, Elizaveta described herself as "not a technical person".

"I studied theatre and only started doing lighting half a year ago. I didn't expect it to be a creative work because before I had always thought of it only as mechanical. Now I really enjoy it and even improvise during the show.

"Slava believes that every person in the company should know how to do everything else – actors should know how to do lighting, sound crew should know how to act on stage so it's a good team. Next, I'm going to learn how to do sound, and Elena is currently learning lighting."

Elizaveta was quite happy with the Janc's Event 60 Plus provided for the Australian shows, and explained the company has just bought an ETC Expression that will be used on future tours. Automated fixtures have not been used on the show before and as Elizaveta explained would only ever be used for gobos and effects.

"We may use them for special effects but not for the main acting lights because Slava doesn't like the restriction of programming because he likes to improvise. When Slava was working in *Cirque Du Soleil (Allegria)* the lighting person hated working with him because as soon as they programmed everything Slava would change it. Even the way we do it we always have special channels set aside so we can follow him around the stage if necessary."

"Light is very important to the show. The most important thing to Slava is that you have to be able to see everything clearly while keeping it intimate and mysterious for the actors."

System Sound supplied a complete sound system for the tour to be integrated with the individual components that tour with the show. The show's audio requirements are mainly sound reinforcement for music and effects from mini-disk, and for voice reinforcement using Sennheiser radio mics. The system included EAW cabinets, with some Meyer CQ1 self powered and UPA1s, and XTADP200 processors. A Soundcraft 24 channel console is used at FOH.

Audio Operator Rastiam 'Roman' Dubinnikov is one of Russia's most famous contemporary musicians and composers. He has worked extensively with Slava over the years and as Elena explains has developed a great trust with Slava.

"Slava really enjoys working with Roman because he knows he can improvise and Roman will follow him exactly."

The soundtrack is a combination of Roman's compositions and famous pieces of music, classical and contemporary.

"Slava chooses the music," Roman explained. "In this show, it's his 'golden collection'. Slava has been choosing this music all his life."

Richard Martin said the crews from Slava's company have been delighted with the Australian venues and crews, and have even joked about wanting to take them back to Russia with them.

"The suppliers have gone out of their way to accommodate the needs of the crew, which is what every international touring production deserves. And the Russian crew have been absolutely thrilled with what we've provided for them.

"And it's just such an amazing show. It's one of the most refreshing things I've seen in theatre in many years. It's just so different – even the most cynical audience would have to enjoy themselves. You would have to be comatose not to enjoy it!"



a microphone cable for every application...



02N6
"on the road" tough
double jacket
copper flex
high flex
6mm OD



D2N6S2
high performance
AES/EBU 110ohm
double screen
6mm OD

eurocable

cables for the new millennium



04N6S2
starquad style
double jacket
double screen
6mm OD



02N4.5
designed for
TT bantam
4.5mm OD



02N3R
high flex
designed for
patch cables
& rack wiring
low profile
3.7mm OD



02N2A
very low profile
foil screen
install cable
2.7mm OD

trc

The Resource Corporation
6 King Street Blackburn Vic 3130
tel: (03) 9877 8233
fax: (03) 9877 8244
email: sales@trc.com.au

Royalties and swindles

☆ Story old as time....

Last month the **Ronettes**, the first great doo whop girl group, won a court victory against their producer - Phil Spector. The Manhattan judge ruled that while Spector's 1963 contract allowed the group royalties on sales of records, the group were entitled to royalties from licensing of their music in movies, advertisements and as background music. Their settlement: A\$4.3 million.

☆ Not always a Fruitcake?

Sure, your writer is still sour, having waited an hour for Guns and Roses to appear at their Sydney concert, 'while the band got their shit together'. Bah.

But bad boy singer Axl Rose isn't quite the eggroll that everyone thought he was, if a story in the latest Rolling Stone is to be believed. The mag says that despite Rose's emotional(!) and legal troubles, including a chain of psychic and new age ripoffs, and allegations of serial wife abuse, Rose apparently enjoyed a neat system which established *who* wrote *what* part of which song. "There were four categories" the story goes, "there was lyrics, melody, music - meaning guitars bass and drums - and accompaniment and arrangement. And we split each one of those into 25 percent". Rose ended up with 41 percent of the bands royalties, and has apparently managed to live off them ever since. Aided and abetted by a record company who have funded a forthcoming album, *Chinese Democracy*, which has been in production for the past seven years.

Royalties on Sales

☐ **MECHANICAL ROYALTIES** are accounted for by the record company. These are different to performance royalties, paid when your song is played or performed anywhere, any time!

Court awards Royalties

From page 8

(The Australian Performing Right Association) in competing claims by both Zelda Sheldon and John Prior. John's claim provided a composer's share for Zelda - but Zelda claimed she had written one hundred percent of the work. APRA had a dispute on its hands, and had both parties lodge statutory declarations detailing their work on the music.

"APRA has handled this brilliantly!" John told me after the court victory. "Considering they were representing two members, and walking on egg-shells".

The court accepted that John tried to resolve the issue early on, and indeed mediation was arranged by APRA in 1994 and entered into by the parties in 1995. The expert determination came down in favour of John Prior, but still no royalties were forthcoming. The dispute was headed for court.

Justice Wilcox was direct in his judgement. "It seems to me that, even on Ms Sheldon's evidence, Mr Prior was a joint author of the original theme". Worse, the judge preferred John Prior's evidence to that of Zelda Sheldon. "I found Mr. Prior an impressive witness. He seemed to me a person who was doing his best to be accurate and responsive". By contrast: "Ms Sheldon turned out to be a most unimpressive witness".



Nevertheless the Sheldon's had defended the action vigorously in court, but made some fundamental blunders. One came early on, when John Prior produced floppy disks of the work he claimed he had done on the music, and the equipment with which to play the files to the court. Amazingly, counsel for the Sheldon's didn't challenge the disks, or question whether they had been created after the time in question.

• **Footnote: John urges anyone involved in the composition of a tune to sort out how to divide the pie - and the best time to do this is when the tune is committed to tape in any form. That's when the parties involved in the composition process should fill out and sign an APRA card. Maybe studios should be pro-active here to assist some younger, less worldly customers retain their intellectual rights?**

The house that music built

John Prior lives and works from inner city Erskinville, where five years ago he and his partner Marea built a home studio from a vacant block of land. Now it stands impressively on a street corner, the entrance leads to a courtyard, the studio on the left and a neat terrace styled residence at the end.

The building was wholly designed to work and live in, and the local council bowed to the argument advanced by John that they they couldn't stop him playing music at home. Musicians have every right to practice, compose, record and even listen to music at home for money or pleasure- alone or with others. This is called 'Home Occupation'.

But the neighbours didn't agree, petitioning council and calling Police the week the building was finished. But it transpired the new noise they were complaining about was a band somewhere across the railway line - John was watching a video that evening!

The studio is *most* impressive. A 6 metre tall live room is at one end, with the control room/creative space built upstairs looking in from above. Throughout are these thick glass German windows and doors which seal virtually airtight, and have a dual action so the top opens like a reverse dormer, for ventilation.

Properly insulated for noise, the live
>continues on page 72

BLACK INC GOES ARTEMIS

Traditional studio prospers by way of innovation. Old and new alongside adds up to a winning combination as Julius Grafton discovers

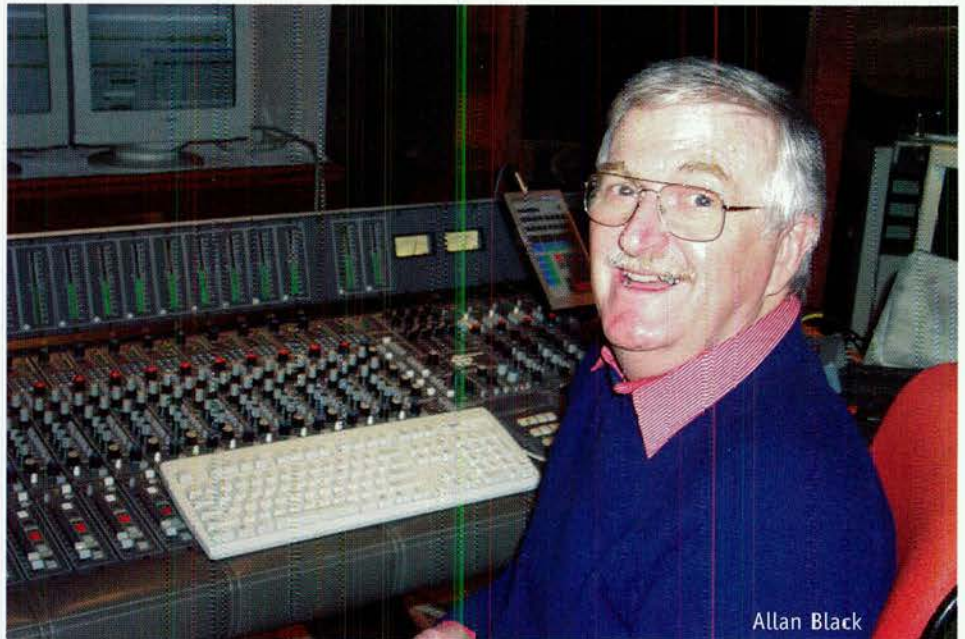

Allan Black

Sydney's miracle mile of recording is conveniently located in St Leonards, adjacent to Artarmon where many video post houses live. This techno enclave is just north of the city, and home to Black Inc Recorders Pty Ltd, since 1978.

Family recording businesses that span a quarter century are thin on the ground, but this one adapts to the future and prospers - because founder Allan Black isn't afraid. He has just bought a SADiE Artemis, the latest iteration of the SADiE 24/96 workstation. It sits happily alongside an analog 24 track Otari recorder, a highly updated Series 34 Sound Workshop desk, and a busy Otari bin loop cassette duplication line that makes thousands of cassettes each day.

Black Inc owns a building that is a recording house, in the sense they have it all - a very respectable studio and live room, replication factory for cassettes and CD's, mixing rooms and more. It all ticks along like a well oiled machine, aided and assisted by keen attention to detail from maestro Allan. For instance - all internal mains wiring was redone from the switchboard back. "God help you if you have poor wiring" says the boss.

There are un-interruptible power supplies on anything crucial. A solid jitter resistant bench for the Microtech CD replication machine. An Exabyte Mammoth high capacity tape backup for the data on hard disk. Monster Cable in the studio: "at \$38 a metre! The batteries nearly died in the calculator!" shouts Allan.

In the cassette duplication area the hardy Otari plant has been subtly modified so it instantly closes down in the event the master tape stops or breaks - and Allan has a

mechanical engineer's eye on all the moving parts. Although getting on to 15 years old, he expects it will churn on reliably for another 10! "I've got upwards of 44 Otari motors in here, and never had one fail" he enthuses.

And finally, because anyone could theoretically engineer or clone a reliable and conducive work environment like this if they had the plans, Black Inc has the workload to keep the place going. It comes from knowing a lot of people, and from being around since stereo was invented. "We're here for the music! Nothing beats the atmosphere of 40 musicians having a good time". It also helps to have a good ear.

Which is where the current investment segues into the story

About three years ago Black Inc evaluated the market, listened to competing digital audio workstations, and settled on a SADiE classic - the original stereo DAW based on and resident within a Windows 95 personal computer. It was a sound decision - that is, based on how the system sounded, what it did, and - free software upgrades. Plus, SADiE was more versatile and could easily handle mastering tasks too - capable of routing a project direct to Black Inc's CD burner stack for fast and automatic runs of up to 400 CD's.

At the time, SADiE sounded better than the rest, says Allan, and today he is uploading sessions done on the SADiE classic and finding they sound even better on his new Artemis system. "Better converters" he says.

One company, many solutions. The Black Inc Otari cassette replication plant grinds on daily, delivering thousands of the hardy plastic tapes. A new CD automated multi-burner can produce 400 CD's, complete and printed, overnight too.

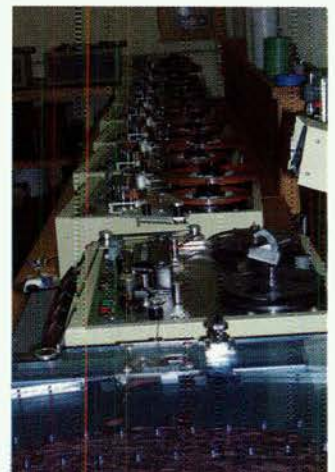

> Goes on over!

Black Inc, from page 71



Artimus is 24 bit, 96kHz capable - and is up against ProTools, Fairlight and Postation - but somewhat less expensive due to its host environment. The system comes in a customised 19" PC rack hardware box which has some serious cooling. In this are the requisite core components and processing cards, depending on the size of the specified system.

Black Inc have a 16 track version, which requires three outboard items of hardware - each in a neat breakout box, 1 rack unit tall. These are an output box (with 16 digital to analogue converters), an input box (with 16 analogue to digital converters), and a digital interface box. You can expand, all the way to 32 inputs and outputs, or buy a smaller startup system.

You put the hardware in the machine room, because any PC or hard disk based system will be too noisy for a control room -

fans and hard drive chatter are a reality of life.

In the control room you can locate custom Artimus control surface hardware - or just have the machine control section of your console do the stop/start stuff, and use a keyboard and mouse for waveform editing and tricky things. Black Inc have two 17" computer monitors built into the wall in front of the console, and Allan swears that once you use two monitors you'll never go back to one. He can put the Edit Decision Lists on one, and have the track waveform on the other, or run it across the two.

Allan is very happy with SADiE and the support he gets from Don Dowling, the Australian distributor. It transpires that Don sold him the Otari plant way back when.

SADiE doesn't have a very high profile in this part of the world, but they have over 4,500 systems installed around the planet.

• SADiE from Neotec Audio, +61 2 9873-3994

From page 70

The house that music built

Get a load of the neat rack/work desk! John's Langley BIG console overlooks the live space --- which is on the next level down.

room is 200 cubic metres in volume and is seven metres wide by five and a half deep. Strips of black stage curtain are hung from a tab track running around three walls, with the back wall overed in carpet. John's kit of drums is setup and he gives me a demo of the room sound. It sounds good! You could fit a 30 voice choir in there.

Upstairs and the control room is also spacious and creative. The 44 channel Big by Langley (Amek) mixer sits at the glass overlooking the live room, and a HUGE custom rack with work desk sits on the left. This rack was built by M-Rack from Melbourne, and accommodates virtually every-

thing John uses - synth modules, keyboard, a pair of Mac computers and monitors, nearfield monitors, outboard effects, sequencers, etc etc. It is on 4" castors, so it can pull out for rear cable access.

John built this whole place on music money. He started playing drums in Matt Finish, a 1980's rock band who had some chart success. He didn't get any songwriting royalties from the band, a fact which stuck in the back of his mind.

"I began learning about music technology in 1984 when composing and producing music for theatre (Griffin, Ensemble, Nimrod) using Fairlight's Sydney studio. The following year I

recorded an album (and studied music theory) in London using mainly digital instruments (synths and samplers) and my eyes were opened further.

In 1991 he started writing advertising music. A set of ad demo's for KFC, McDonalds and Coke followed, these lead to over 500 ad tracks for these corporations.

These days he produces for various people (as Mammal Music), and releases indie CD's as Mammal Records. This is a successful venture - for example, iOTA enjoyed the number 1 Australian Independent album in 1999 with 'The Hip Bone Connection'

John has some CD's of library music on sale, and writes, produces and plays music as he sees fit. He has built a modern and totally creative and functional space, with a neat house out the back.





Artist	Producer	Engineer	Notes
New South Wales			
A#Sharp Jeff Cripps 24 track Analogue 8 track Digital			
Shneiders Ape	Jeff Cripps	Jeff Cripps	Unearthed Track
Jim Finn	Jeff Cripps	Jeff Cripps	CD
Tale Of Two Cities	Jeff Cripps	Jeff Cripps	Opera CD
Greg Poppleton	Jeff Cripps	Jeff Cripps	CD
Heroes From Heaven	Jeff Cripps	Jeff Cripps	CD
Aphek Studio Greg Dixon +61 2 98766 8170 16 Track Analogue 1" + hard Disk + Soundcraft Ghost			
Corsica	Corsica	Greg Dixon (E)	Demo
Dog Rocket	Dog Rocket	Greg Dixon (E)	Demo
BackySkank	Simon Smith	Greg Dixon (E)	Album
Barney	Barney	Greg Dixon (E)	Album
Boulder Bay Studio Rob Godwin +61 24982 7711 8 Track Tascam Analogue & 16 Track Hard Disk Yamaha			
Two Ton Monk	Rob Godwin	Rob Godwin	EP "From Here On In"
Garden Party	Rob Godwin	Rob Godwin	TV Jingle & EP
Damien Gerards Marshall +61 2 9555 1710 2" 24 Track Analogue, Pro Tools Digital			
Whichaway Sessions	Rose Pierce	Russ Pilling/Kristian Hill/N. Johnson	Album
Rex Goh	Rex Goh	Russell Pilling	EP
Monstrous Blues	Russell Pilling	Russell Pilling	EP
Elysium	Marshall Cullen	Russell Pilling	EP
Ashtray Boy	Randall	Russell Pilling	Mixing Album
JMF Recording Fran Esther +61 2 9790 4097 24 Track 2" Analogue. 24 Track Adat Digital			
Miran's Army	Miran's Army	Ralph Esther (E)	Demo
Spent	Spent	Ralph Esther (E)	Demo
Wendy Wells	Wendy Wells	Guy Saminaden (E)	Demo
Anglican Youth Works	Marc Bonnici	Ralph Esther(E) Mark Bonnici(P)	Album
Mary Schneider	Mary Schneider	Glenr Phimister	Album
Megaphon Studios Shane Fahey +61 2 9550 6576			
Mick Hart	Jim Mogine	Brent Clark	
Frenzal Rhomb	Phil McKellar/Frenzal Rhomb	Phil McKellar	
Muzzy Pep	Phil McKellar	Phil McKellar	
Christine Anu	Stuart Crichton	Brent Clark	
Waikiki	Tim Whitte r/Waikiki	Tim Whitten	
Nu-Town Studios Greg Hopping +61 2 9516 3303			
Jaqui Hunt	Jaqui Hunt	Sofie Loizou (PR)	Demos
Blue World	Greg Hopping	Mark Worrall (E)	Album
Mark Edwards	Greg Hopping	Sofie Loizou (PR)	Demos
Senani	Sofie Loizou/Senani	Sofie Loizou	Single
Jeff Wistom	Greg Hopping	Sofie Loizou	Single
Paul Bryant Mastering Paul Bryant +61 2 9874 3133 Mastering Suite			
Carlson Chorale	Glenr Phimister (E)	Paul Bryant	CD Album
D'Olv	Ross A'Hern (E)	Paul Bryant (E)	CD Album
Vermillion	Geoff Lee (E)	Paul Bryant (E)	CD master
Bernie McGann	Ross A'Hern (E)	Paul Bryant (E)	CD Album
The Next	Jeff Cripps (E)	Paul Bryant (E)	CD Master
Q Recording Studios Richard Muecke +61 2 9212 4851 SSL G+ 4040 Studer A827 2"			
You Am I	Geoff Norell	Geoff Norell (E) Chris Corby (PR)	Album
Frenzal Rhomb	Phil McKellar	Phil McKellar (E)	Mix
R & R Recordings Rob Zimola +61 2 9672 4494 16 Track Analogue/Digital			
Dom O'Leary	Rob Zimola	Rob Zimola	Album
Skeptic	Nick Haertsch	Nick Haertsch	Demos
Kevin Adams + Pat Murrey	Kevin Adams + Pat Murrey	Rob Zimola	Demos
Rockinghorse Vern +61 2 6688 4005 Neve V Series 48 channel Console, Studier 24 Track Pro Tools Mix 24			
Chenlab	Anthony Lycenko/Christian Pyle	Anthony Lycenko (E)	EP Tracking
Ten Tenors	Brendan Morley	Brendan Morley (E)	Album Tracking
Vermin	Anthony Lycenko/Vermin	Anthony Lycenko (E)	Album Tracking+Mixing
Amphibian	Rob Walsh	Michael Worthington (E)	Album Mastering
Alegro Gone Troppo	Alegro Gone Troppo	Michael Worthington (E)	Tracking
Skylab Dave Russell +61 2 9310 4774 Analogue 24 Track Ampex 2". 32 Track Digital			
Doug Williams/John Paul Young	Gudu	Spaceman (E)	Single
The Nevilles	Anthony Williams	Spaceman (E)	Album

CHARTS



ARTIST: Kaylan
SINGLE: Rock Me All Night
PRODUCED BY: Rockmelons
STUDIO: Bear Tracks Studio - New York
ENGINEERING: Earl Cohen
MASTERING: Kathy Naughton @ DB Mastering
PROGRAMMING: Kaylan
NOTES: Touring with Vengaboys & Destiny's Child in July. Touring with B=dot in August.



ARTIST: Madison Avenue
SINGLE: Who The Hell Are You
PRODUCED BY: Madison Avenue (Andy Van & Cheyenne Coates)
STUDIO: Backbeach Recording Studios - Victoria
ENGINEERING: Mark Rochelle
MASTERING: John Ruberto @ Crystal Mastering - Victoria



ARTIST: The Whitlams
SINGLE: Blow up the Pokias (Thankyou For Loving Me At My Worst)
PRODUCED BY: Daniel Denholm
STUDIO: Ocean Way Studios - LA
ENGINEERING: Jack Joseph Puig
ADDITIONAL RECORDING: Dave Schiffman @ Celc Studios - LA



Fat Trax

Fat Trax have launched their new and improved web site featuring loads of information about their in-house facilities, equipment and staff. Check it out at www.fattrax.com.au and let David know what you think of it on +61 8 8231 5199

Indent Music

Dave McDougall reports Indent have just upgraded their ProTools plugins to include the Bombfactory 1176 and LA-2 software compressors. They have also changed one of the guitar amp rooms to a small 'live' recording room. For more details call Dave on +61 3 9381 2636

Studio 52

Paul Higgins reports a busy month at Studio 52. They've just finished mixing the first single for new Sydney pop act 'Delta'. At only 15 and managed by Glenn Wheatley, Delta's first single 'What Kinda Girl' is aimed for an August release. The song was written and produced by Trevor Carter.

• Paul and Trevor's Kool Skools project is once again happening, and this year marks the project's national debut. Recording kicks off in July at Studio 52 in Melbourne, Fat Trax in Adelaide, Velvet Sound in Sydney and Gingerman on the Gold Coast.

With around 300 school-age bands set to participate, recording will run until mid October, with awards nights planned in each participating state in November. More than just a 'battle of the bands', Kool Skools aims to capture all the elements of the industry in one project.

For the first time the Kool Skools CDs will also have a

Artist	Producer	Engineer	Notes
Lynda Wehipehana Jonah Spark Tito/Poison Pinto	Phil Grove Jonah Spark Tito	Dave Russell Dave Russell Dave Russell	Single EP
Sony Music Studios Ross A'Hern Multitrack recording studio			
Alister Spence Trio	Alister Spence	Ross A'Hern (E)	Record + Mix Album
Ten Part Invention	Ten Part Invention	Ross A'Hern (E)	Record + Mix Album
Baecastuff	Ric Robertson	Ross A'Hern (E)	Record + Mix Album
Lo-Tel		Louise Taylor (E)	Mix Tracks
Elsewhere Fine	David pascoe	Todd Deeley (E)	Recording + mixing Album
Soundwarp Meredith Brooks +61 2 99055 7144 Mastering			
Various	Smithy	Meredith Brooks	Restoration of 78's
Neo Darwinism	Jack Tinnapple	Meredith Brooks	Album
The Flares	Brian Dolly	Meredith Brooks	Album
Jordan	Jordan Roach	Meredith Brooks	EP
Voodoo Monkeys	Mike	Meredith Brooks	Mini Album
Sound Level +61 2 9552-3200. 24 track DA 88 / Ensoniq Paris 16 track hard disk.			
Bluebirds	Bluebirds	Pat Salloch	Album
Women of Troy	Women of Troy	Ian McDermont	Demos
Daredevil	Daredevil	Jorden Brebach	Album
Astro Tobasco	Astro Tobasco	Jorden Brebach	Album
Paul Mulhearn	Paul Mulhearn	Jorden Brebach	Demo
Studios 301 +61 2 9698 5888 Three 48 Track studios 48 Track Analogue 48 track Sony Dash Format, 48 Track Pro Tools & 48 Track Radar 2.			
Grace Knight	Tom Misner	Tom Misner/Jochen Muller	Album
Christine Anu	Stuart Crichton	Brent Clark	Album
South Pacific(Harry C Junior+Glen Close)	Michael Gore	Joel Moss	Album
Savage garden	Tim Palmer	Tim Palmer	HBO TV Special
Lucinda Peters	Richard Lush/Don Burrows	Richard Lush	Album
Midnight Oil	Magoo	Magoo	Single
301 Mastering Jaquie Espie +61 2 9211 7301 Mastering + Audio Post Production			
The Three Divas	Paul Nejar	Don Bartley	Forthcoming Album
Melinda Schneider	Graham Thompson	Steve Smart	Forthcoming Album
Powderfinger	Nick Didea	Don Bartley	Track for M12
Custard	Custard	Steve Smart	Best of Album
Resin Dogs	Resin Dogs	Steve Smart	Forthcoming Album
Tiger Recording Lynda/Julie +61 2 9222 4700 Euphonix S3000, Sonic Solutions			
Marcia Hines	Michael Szumowski	David Hemming	Single-Olympic Album
Grace	Tommy Farragher/Nick Howard	David Hemming	Demos
Bardot	Tommy Farragher/Nick Howard	David Hemming	Single
Rai	Rai	David Hemming/Ben Gardener	Singles
Top Cat Recording Studio Brad Wann +61 2 6628 0233 Analogue 1", 24 Track Pro Tools Mix 24 Plus			
Forte	Brad Waan/George Christie	Brad Wann (E)	Album Tracking
Six Seconds Slower	Brad Wann	Brad Wann (E)	EP Mixing
Greg Champion	Greg Champion	Brad Wann (E)	Footy Show Edit
Momentom	Brad Wann	Brad Wann (E)	EP Mixing
Tony Llewellyn	Tony Llewellyn	Brad Wann (E)	Album Mastering
Trackdown Digital Mike Duffy +61 2 9550 6890 64 Tracks/Post + Music			
Magic Pudding	Chris Harriott	K. Naunton(E) T. Ryan(E)	Film S/track
Hi 5	Chris Harriott	K. Naunton (E) D. Candusso (E)	TV Mixes
Tabaluga	Yoram Gross-EMTV	Torei Lista (E)	TV Post
Mad Dash	Mad Dash	Damian Candusso	EP
Flipper Series 2	Yoram Gross EMTV	Torei Lista(E) Damian Candusso(E)	Post
Velvet Sound Recordings Dave McCunn +61 2 9267 2915 Pro Analogue & Digital recording, mixing & editing			
Weta	Steve James	Tony Wall	Album
Pretty Violent Stain	Phil McKeller	Phil McKeller	Album
Nevyn	Gia	Adrian Grigorieff	Album
The Titanics	Greg Wales	Greg Wales	EP
Patchboy	Michael Letho	Michael Letho	EP
Vehicle	Band	Adrian Grigorieff	EP

Queensland

Foxhole Audio Productions Mick Rayner +61 7 5262 5150 32 track Pro Tools & Analogue.

Tracking Guide



Artist	Producer	Engineer	Notes
The Flying Chinnees	Jeremy Allon	Jeremy/Mick Rayner (PR)	Album Mixes
Citizen Khane	Band/Mick Rayner	Mick Rayner	Single Mix/Album Tracking
Fitness & dance Studio	Karen Alexander	Mick Rayner	Editing Dance Tracks
Glenn Carmody	Glenn Carmody	Mick Rayner	Demos
OPM Studios Daniel Seymour +61 7 3374 0066 Edits with logic audio & mackie Console			
Alchemy	Craig Thomson	Daniel Seymour	Single/Remix
Shi	Tim Norris	Daniel Seymour	Single
New Settlement Rogue	New Settlement Rogue	Daniel Seymour	EP
Exposed	Daniel Seymour	Daniel Seymour	Demos
Asrtiaal	Astriaal	Daniel Seymour	Album
Stargate Music productions Dash Mclvor +61 7 3260 6294			
Kerry Renae Boyle	Dash Mclvor	Dash Mclvor	EP
Jim Cooper	Dash Mclvor	Dash Mclvor	Poetry Album
Rob Black	Dash Mclvor	Dash Mclvor	tracking
Brett Goodwin	Dash Mclvor	Dash Mclvor	Album
Kelly Mellers	Dash Mclvor	Dash Mclvor	Tracking
Vandersound Studios Eric Vandersande +61 7 5E46 8100 All Digital 8 Valve, Adat/XT, 02R, HDR, CDR			
02 Deli	Toby Masterson/Andrew Hines	Toby Masterson (E)	Edit EP
Chin	Eric Vandersande/Dave Witmer	Dave Witmer (E)	Edit EP
Blazay	Eric Vandersande/C. Walls	Dave Witmer (E)	Edit & Mix Demo
Cosip	Eric Vandersande/Cosip	Eric Vandersande	Mix & Master EP
Blunt Object	Eric Vandersande	Eric Vandersande	Mix & Master EP

South Australia

Disk Edits Pty Ltd Catherine Linke +61 8 8340 1377 Audio mastering & pcst production, CD & cassette Manufacturing			
Teylah James	T James/H Garcia/J Du Cornet	Neville Clark	Mastering/Manufacture
Cross Bred Mongrels	Cross Bred Mongrels	Neville Clark	Mastering/Manufacture
Brunatex	C Dickie	Neville Clark	Mastering/CD Manufacture
Dirty House Records	T Bambacas	Neville Clark	Mastering/CD Manufacture
Fat Trax David Grice +61 8 8231 5199 64 Track Music + Post Production Facility			
Alpha Centauri	Alpha Centauri	David Grice (E)	EP
Tommy	Tommy	Matt Williams (E)	EP
Candice & Nadinne	David Grice & Richard Ortner	David Grice (E)	Album
Fred Grice	David Grice	David Grice (E+PR)	Album

Victoria

Audrey Studios Craig Pilkington +61 3 9415 8599 Analogue, Digital, Hard Disk, One off CDs, Powerful, Sampling/Sequencing, Automated mix			
Killjoys	Craig Pilkington	Craig Pilkington	Album
Archie Roach	Craig Pilkington	Craig Pilkington	Album Demos
Anna Burley	Craig Pilkington/Anna Burley	Craig Pilkington	Solo Album
Dinsdale	Craig Pilkington	Craig Pilkington	Album Tracking
Nabarlek Band	Terra Guyr ala/Craig Pilkington	Craig Pilkington	Album Demos
Baker street studios Allan Neuendorf +61 3 9883 8084 32 Track Digital, Grand Piano, Music/Voice Over Facility			
Paul Coleman	Paul Colmen	P. Gaudion (E) + A. Neuendorf (E)	Album
The Turnarounds	The Turnarounds	Allan Neuendorf (E)	Album
Jeff Gibson	Jeff Gibsor/Allan Neuendorf	Allan Neuendorf (E)	Album
Kathie Chan	Jared Haschek	Allan Neuendorf (E)	Album
Mark Westby	Mark Westby/Allan Neuendorf	Allan Neuendorf (E)	Album
Crystal mastering Joe Carra +61 3 9326 2318 CD Mastering Facility			
Madison Avenue Vans/Rochelle	John Ruberto (E)	Mastering Remixes	
Johnny Young	Young/Wilson	Joe Carra (E)	Mastering Singles
Broken Watches	Broken Watches	John Ruberto (E)	Mastering Album
Kieran McCarthy	McCarthy/Dillon	John Ruberto (E)	Mastering Singles

Dex Mastering Adam Dempsey +61 3 9372 2265 Pro CD mastering since 1982.			
Sonic Solutions + No Noise™ + Custom Analogue Gear			
Alex burns	Alex burns/Ben Hurt	Adam Dempsey/Ben hurt	Album
Nadir	Band	Adam Dempsey	7 Track Album

multimedia component to them. The disks will be CD Rom enhanced and will feature photos and background information about the bands and the project. For full details about the project, check out www.koolskools.com.au

Rockinghorse

Vern Pramschufner has joined forces with Rockinghorse to establish a new production company, Blue Room productions. Hailing from London, Vern is a renowned music producer in the international industry - running Pink Floyd's old recording studio in Islington is just one of his claims to fame.

Vern has relocated his equipment and years of experience to Rockinghorse in order to get Blue Room up and running, and is looking for young talented singers for cutting-edge R&B and melodic power-pop tracks. Successful artists will receive full production deals and generous percentages.

Rockinghorse has recently upgraded to ProTools system 5 with Genelec monitoring. For more information on Blue Room call Vern at Rockinghorse on +61 2 6688 4005.

Satellite Recording

Darren Halifax from Satellite Recording Studio in WA writes:

"Here's one for the books. Between time serving two lengthy jail stints for having the guts to do what most of us would love to do (punch out a policeman) local artist Billie Reid recorded what I consider to be an absolute gem of an album. 'Ticket out of Disneyland' contains 14 non-nonsense songs featuring pretty much an all-star lineup.

Studios 301 Expansion

Studios 301 have just acquired the adjacent property in Alexandria and plans to expand



the studios are currently before the local council. New additions will be a further large control room and a coffee shop. The new control room will be the same design as the current main rooms at 301, but with a new dark green colour scheme.

301 will also be home to Australia's largest ProTools system – 96 tracks including the ProControl operating surface and a number of classic outboard effects, as well as most of the available ProTools plugins. The system is housed in a custom made console with three plasma displays and surround metering.

Also new to 301 is the new Sony Dash 48 track. The new format will make Studios 301 compatible with the main US studios and bring all professional audio standards to the studio.

Tom Misner has redesigned the main mastering control room (the original Phoenix Room) acoustics with new B&W Nautilus 802 studio monitors for stereo and the Genelec surround system. Surround reverb and compression is controlled via the new TC 6000 surround system. The new control room will be able to handle mastering in 5.1 surround with DVD audio.

The other mastering studios have been upgraded with the addition of various high class outboard effects and 24 bit DAT players.

Damien Gerard

New arrival in Sydney Nathan Johnson joins the DG's team this month as main assistant (bringing with him a welcome set of TLA and Focusrite preamps, 2 X ADATS and Pro Tools peripherals&expertise).

He fills the gap left by Kristian Hill moving to studio



Artist	Producer	Engineer	Notes
Geek	Darryl Shallard	Adam Dempsey	EP
P. Tex	P. Tex	Adam Dempsey	Album
Subgenius	Rohan Voigt	Adam Dempsey	EP
Edensound Mastering Martin Pullan +61 3 9381 2636 64 Track Pro Tools, specialises in recording bands live to multi-track, 5 separate recording areas.			
Lydia Denker	001 Productions	Martin Pullan	'Real to Me'-Single
Killing Heidi	Paul Kosky	Martin Pullan	Various Mixes
Spencer P Jones	Tony Cohen	Martin Pullan	Album
Deep Purple	Dr Drew Thompson	Martin Pullan	Sydney '84
Thread	Dave Hannon	Robbie Adams	Never Look Back
Indent Music Dave McDougall +61 3 9381 2636 64 Track Pro Tools, specialises in recording bands live to multi-track, 5 separate recording areas.			
Acid Babies	Dave McDougall/Acid Babies	Dave McDougall	CD Demo
Tomola	Dave McDougall/Tomola	Dave McDougall	CD EP
Fungus	Dave McDougall/Fungus	Dave McDougall	Demo CD
Chimera	Dave McDougall	Dave McDougall	Demo
Rolling Blue	Dave McDougall/Rolling Blue	Dave McDougall	Pre Production Demos
Studio 52 Paul Higgins +61 3 9417 7707 Studio A+B Both 48 Track			
Delta	Trevor Carter	Andrew Meakes/T Carter	Remix single
Winter 2C Music Festival	Rod Paine/Paul Higgins	A Meakes/Mitch Kenny	Mastering
Jacques Brel is Alive & well	Location recording	Mitch Kenny	Live Show Recording
Freaky Jason	Hayden Watt	Mitch Kenny	Song for Radio Sampler
Sweet Painted Ladies	Band	Mitch Kenny	Recording+Production of EP
The Ranch Norman James +61 3 9712 0136 Studio/Farm			
L'Heure	Sean Claude	Norman James	CD Album
Fouad	Fouad	Norman James	Demos
Ian Blackeney	Ian Blackeney	Norman James	Radio Single
Various	A.M.M.A	Norman James	Eat'M 2000 CD
Various	A.M.M.A	Norman James	Pop Komm 2000 CD's
True Form Recording Neil Gray +61 3 9391 0907 24 Track Analogue Recording, + Digital + Hard Disk Editing			
Dee-Nik	Neil Gray	Neil Gray (E)	EP
Surdo	Rosco/Band	Ross O'Driscoll (E)	Mix Album
Stinkfish	Chris Dyson	Neil Gray (E)	Live to D.A.T
Various with Peter Doyle	Tony Leonard	Neil Gray	Compilation Album
Wombat Rd Recording Studios Barrie Clissold +61 3 5145 4204 24 track Digital + 16 Track Analogue, Digital Mastering, Duplication			
Jim Taylor	Barrie Clissold	Barrie Clissold (E)	CD Duplication
S Raza	Barrie Clissold	Barrie Clissold	Album
Vicky, Anna & Amy	Barrie Clissold	Barrie Clissold (PR)	CD Album
G Rowlings	Barrie Clissold	Barrie Clissold (E)	Duplication
Woodstock Red +61 3 9631 9011 24 track Music Recording Studio			
Even	Even	Chris Dickle	Album
Renee Geyer	Joe Camilleri	Michel Letho	Album

Western Australia

Bonsai Tom Thorpe +61 8 9246 4408 Pro tools & Analogue studio			
RPM	Seeing ear/Tom Thorpe	Tom Thorpe (E + PR)	Album Tracking
Peter Bevan	Peter Bevan	Tom Thorpe	TV Jingle
Mike Blake	Tom Thorpe	Tom Thorpe	Album Tracking
Mr Mac	Keith MacDonald	Tom Thorpe	Mastering CD Project
Planet Sound Studios Trevor Spensor +61 8 9382 2211			
Lee Bradshaw	Lee Bradshaw	John Villani	CD Project
Poonshead Rob + Sam +61 8 9339 4791 Music Recording, Production, Mastering			
Lux Mammoth	Alan Smith	Rob Grant (E)	Mastering
Penelope	Penelope	Rob Grant	Album
Leon Ewing	Leon Ewing/Rob Grant	Rob Grant (E)	Album
Smoking hats	Smoking Hats	Rob Grant	Album
Down & Under	Rob Grant + Chris Giles	Rob Grant (E)	Single
Poons Head Rob + Sam +61 8 9339 4791 Music recording, Production, Mastering			
Lux Mammoth	Alan Smith	Rob Grant (E)	Mastering

Tracking Guide



Artist	Producer	Engineer	Notes
Penelope	Rob Grant/Fenelope	Rob Grant (E)	Album
Leon Ewing	Rob Grant/Læon Ewing	Rob Grant (E)	Album
Smoking hats	Rob Grant/Smoking Hats	Rob Grant (E)	Album
Down & under	Rob Grant/Chris Giles	Rob Grant (E)	Single
Revolver Sound Studio Vic Manfrin +61 8 9272 7503 32 Track Automated Analogue & Digital			
Spencer Tracy	Ben Glatzer	Ben Glatzer	Tracking
Nathan Gaunt	Nathan Gault/ Ben Glatzer	Ben Glatzer	Tracking
Flagship	Flagship/ Ben Glatzer	Ben Glatzer	Tracking
Wax Tadpole	Wax Tadpole/ Ben Glatzer	Ben Glatzer	Mixing
Love Camp	Love Camp 7	Vic Manfrin	Tracking
Satellite Recording Studio Darren Halifax +61 8 9470 4003 Pro Tools, 64 Tracks, 24 Bit			
Jim Fisher	James Hewgill	James Hewgill	Record
Michelle Demkiv	Tony White	Darren Halifax	Demo
Another Light	Another Light	Darren Halifax	Album
George Vegas	George Vegas	Darren Halifax	Demo
No Flowers	No Flowers	Darren Halifax	Album
Sonic Solutions Edit Room Mark Whitehouse +61 8 9375 3902 Mastering & Editing Suite			
Association For The Blind	Keith Potger	Mark Whitehouse	CD Project Album
Perth Wildcats	Perth Wildcats	Mark Whitehouse	CD Project
Harold Schenberg	Bob Hawker	Mark Whitehouse	CD
Sweet Adelines	Sweet Adelines	Mark Whitehouse	CD Project Album
KPL Entertainment/Kathleen Lakey	KPL Entertainment	M Whitehouse	CC Album

To list your studio here, call Sarah on 1-800-635-514



BASF YOUR MUSIC IS
SAFE WITH US

YOUR BASF TRADE SALE OUTLETS:

NSW:

Audio Visual Designs (02) 9281-2444
Silver & Ballard (02) 9439-5355
Independent Tape Services (02) 9436-0666
MT&A (02) 9310-2799

VICTORIA:

CATS (03) 9529-3177
Chapple Tape (03) 9580-6620
DEX Audio (03) 9372-2266
MT&A (03) 9819-6455

SOUTH AUSTRALIA:

Adelaide Tape Duplicators (08) 8212-7111
Pro Media (08) 8276-6793

WEST AUSTRALIA:

Ausmag (08) 9314-1953
Pro Copy (08) 9375-3902

QUEENSLAND:

Musiclab (07) 3252-2188
Tek (07) 3239-4000

engineer some time ago. Kristian has been kept extremely busy lately with the new Pro Tools Suite in the Retro Room (within Festival Studio) working on projects such as Andy Jones Childrens Album for The ABC and The Sydney Childrens Choir.

The Retro Room can now handle transfers from pretty much any format, either analog to digital - or the other way.

STARGATE GO PARIS

A new 16 in/out Ensoniq Paris workstation takes pride of place at Stargate Music Productions. It is fully integrated with the existing ADAT, ProTools and Logic Audio systems. On 'yer, Dash McIvor!

RENEE at WOODSTOCK

Music worth waiting for as Renee Geyer (love the book!) cuts a new album with songs from Ross Wilson and Ross McLennan at Woodstock. Produced by Joe Camilleri and engineered by Michael Letho - can't wait to hear this one!

METROPOLIS GO 960L!

Metropolis Audio have purchased a new Lexicon 960L multichannel digital effector. It boasts 24 bit/96KHZ processing with true multi channel surround reverb processing. It comes with a 480L based LARC remote, and has multiple 3 DSP configurations, including stereo and 5.1 surround. It's got a joystick for surround panning.

TRUE FORM

Production has commenced on a new album featuring a variety of vocalists, such as Marcie Jones, Danny Robinson and Tony Worsley, etc. English producer/drummer Tony Leonard spent a few weeks in Aus helping out. (Hey- We remember him from Gary Glitter's Glitter band! Long time ago - Ed).

Keep that news 'comin!

World's easiest subscriptions!

Au \$52 1 yr*
Au \$86 2 yrs*
NEW ZEALAND:
Au \$80 1 yr
Au \$120 2 yrs
ASIA:
Au \$80 1 yr
Au \$140 2 yrs
USA:
Au \$115 1 yr
Au \$199 2 yr
EURO:
Au \$125 1 yr
Au \$240 2 yr

Step one. Decide to save 25% or more.

Step two. You want your mag early, before the newsagent.

Step three. You know we are very trusted to do this right!

3 VERY EASY WAYS TO SUBSCRIBE:

(A) Use our online form at www.conpub.com.au ; or -

(B) Just Call Sarah on 1-800-635-514 in business hours.

*Price includes GST



What Pisses Me Off, Part 2-

Airlines. Flying High (and Late)

I've had to fly a fair bit lately, and I tell you what - the more you do it, the less you enjoy it. Not the actual flying, because once you're airborne at least you can feel like you're actually getting somewhere. No, it's the endless hours spent hanging around airports, waiting, waiting, waiting - they all add up to days, even weeks out of your life.

Let's face it, as far as airlines are concerned, us passengers are just a nuisance. They would much rather be carrying some airfreight. It doesn't complain if it's late taking off, doesn't need to be fed, kept warm, comfortable, or entertained - in fact, unless there are a couple of pets included, airfreight doesn't even need air!

The recent trip to the Frankfurt show as detailed in last month's Slide Night almost didn't happen. We were booked to fly from Melbourne to Singapore on Cactus Airlines - oops, sorry, Qantas - then get a connection straight through to Frankfurt. This would have delivered us there in the morning of the day before the show - plenty of time to set up the stand, and catch some sleep.

So, we got on to the plane and after a few minutes it taxied out to the runway and stopped. And stayed stopped for quite a long time. Then the captain came on the PA and said that there was a problem with the generators and air conditioning, the plane wasn't in a safe condition to fly, and we'd be returning to the terminal. A collective groan came from all the passengers who were probably on similar schedules to us, and we taxied back to the terminal and got off.

We then waited in the lounge for a couple of hours, and then got back on the plane. There still seemed to be some problem with the air-con, as the cabin of the plane was like an oven, and the temperature of the air coming out of the vents was so hot that I was worried we'd be done like a nicely roasted chook by the time we hit Singapore. The pilot obviously thought so too, and unhappy with the thought of flying a mobile chicken rotisserie he put us back into the terminal again!

We eventually took off seven and a half hours late, all connections missed, schedules shot to pieces, roughly about the time we should have been soaking up a gin sling or three in Singapore.

Now, I've got no problem with the pilot not wanting to fly the plane until it's OK. I figure that he's just as keen on staying in one piece as I am, and if he with his infinitely superior knowledge of all things aeronautical says the plane needs fixing, then I'm more than happy to go along with him.

But it was the fact that the plane was delivered to him in such a condition that really pissed me off. Planes are complex things, and something can need fixing, but it's the regularity that this happening lately that worries me. And in case you're wondering, it wasn't the same plane that fell off the runway in Bangkok, because that particular plane had broken down somewhere else!

When you're on the plane, and just getting settled in, the cabin crew goes through the compulsory safety demonstration. Does anyone else apart from me ever watch it? If they do, then surely they must laugh at the phrase "in the event of a water landing". Can anyone even vaguely imagine a jumbo landing on water? They're land planes, not seaplanes. They're not even allowed to land on a runway with full fuel tanks in case the wings snap off, so what hope do they have in the water? Not too damn much.

On United they show a video where everyone is just so-o-o calm when the plane loses cabin pressure and the oxygen masks drop down. Everyone smiles and puts their masks on. Not one person does the obvious, which is jumping up and running around waving their arms and yelling "SH-I-I-I-IT!" while trampling over children and old ladies in a mad rush to escape! There's even a scene in the video where a guy is sitting in the toilet and the mask pops down. He calmly puts down his magazine and slips on the mask. Can you believe that? If I was sitting in the dunny, patiently waiting for nature to take its course, when all of a sudden the oxygen mask dropped down in front of me, I reckon it would have the same instant effect as swallowing a kilo of elephant laxative!

And another thing. Don't you just hate it when you get on the plane with your one small piece of hand luggage, and the overhead lockers are all jammed full because your fellow passengers are a pack of lazy bastards who can't be bothered waiting for their luggage to come off the carousel, so they carry all six pieces of it on as hand luggage? Suitbag, briefcase, laptop, backpack, duty-free shopping, wheelie cart, you name it, they've managed to drag it onto the plane with them, and it's all squeezed into *your* overhead locker. Something as fragile as a computer I can understand keeping close at hand, but hey, if they're so insecure they can't bear to be parted from their precious luggage for even an hour, then they can bloody well carry it on their laps.

The other day I had to fly to Brisbane on urgent family business. No time to pre-book, no time to organise using some mileage points, just time to buy a ticket and go. Airlines must absolutely love people in this position (what position? Well, bent over a barrel with your pants around your ankles is what immediately springs to mind), people who must fly right here and now.

I rang each airline for the best price, but oddly enough, there is just so much competition between the two of them that the price was exactly the same. What a coincidence! No wonder they hate the thought of Virgin and Impulse encroaching on this cosy little arrangement. The price? Nine hundred and fifty nine dollars return (I've spelled it out so it can sink in slowly), the standard economy fare!

Still, at least you'd expect to get a decent meal for that price, wouldn't you? Think again. The sumptuous in-flight meal consisted of a muffin and a cup of coffee.

That's what *really* pissed me off!

Classifieds

Only free if lodged by email, fax or post: email nic@conpub.com.au, fax: +61 2 9876-5715, Post-PO Box 439, EPPING NSW 2121 Aust. Display/paid classifieds: call Nic, 1-800-635-514 Text: first 15 words free, then \$15 per 15 words or part

AUSTRALIAN FILM TELEVISION AND RADIO SCHOOL TECHNICIAN

AUDIO SYSTEMS MAINTENANCE

\$39224 TO \$44503 (BASE SALARY)

The AFTRS is seeking a technician to install and repair professional sound production equipment including a broad range of analogue and digital recording equipment, computer-based sound editing equipment and audio networking systems. This position is also required to provide technical support for the AFTRS' telephone (voice and data) system, and to assist in training technical trainees.

The successful applicant will have relevant professional qualifications and possess a thorough technical understanding of computer technology. Experience with Windows NT and Macintosh operating systems is essential as is experience in the installation and maintenance of professional equipment. The ability to design and develop prototype circuits to interface equipment is desirable. Mechanical skills are an advantage.

Terms: This position is available on an ongoing basis and can only be offered to an applicant with Australian Citizenship or Permanent Residency.

Enquiries: It is in the applicant's interest to contact Human Resources on (02) 9805 6616 or 1300 366 464 (toll free) to obtain an application package prior to drafting an application. This information can also be obtained from the AFTRS web site at www.aftrs.edu.au. If you have further questions you may contact Colin Franks, Engineer, on (02) 9805 6515.

Applications: Written applications giving full details of qualifications and experience and nominating 2 referees should be forwarded to:

The Human Resources Manager
Australian Film, Television and Radio School
PO Box 126
North Ryde NSW 1670

Closing Date: Friday, 21 July 2000

The Australian Film, Television and Radio School supports workplace diversity.

Sole Agency Opportunity

- Professional Audio
- International market leader
- Sole agency for NSW and QLD

This is a unique and excellent opportunity to win the sole agency for a well known and recognised high quality professional range of audio equipment.

This agency is well suited to either a dynamic and pro-active person wanting to start their own business or to an established company looking for additional products to complement their existing product range.

Full product support and assistance will be provided by the local Head Office of this international company and a generous commission scheme is offered.

To be successful with this agency you will have established networks and high standing in the professional audio marketplace. Technical capability and knowledge, and demonstrated capacity to market these products effectively will be important.

To express your interest in this opportunity, contact in confidence Ken Lucas, swa@swacorp.com.au phone on (03) 9525-0066 or Freecall No 1800 819-113, fax to (03) 9525-0088 or mail your detailed resume.

Interviews will be conducted in Sydney.



SENIOR AUDIO VISUAL TECHNICIAN

STAGWORKS AUSTRALIA is the largest supplier of audiovisual and themeing services in Far North Queensland. An exciting opportunity exists for a highly motivated, dedicated individual to be a part of this dynamic team.

The successful applicant will have an excellent understanding of all technical aspects and of the operation of associated equipment for the conference industry. As the position involves interacting with clients, event managers and coordinating crew, excellent communication skills are essential.

The applicant should have **proven experience in the conference or audiovisual industry, including the setup, operation and packdown of video and data equipment, lighting, audio and projection systems.**

Expressions of interest should be received no later than July 30th by emailing your CV and application letter to sales@stageworks.com.au or fax to (37) 4032 2811

POSITIONS VACANT

WORKSHOP MANAGER, Parade NSW Centenary of Federation. For information contact: Kathy Fatouhar. PH: +61 2 8274 2340

WANTED

AUSTRALIAN Tour Memorabilia and papergoods wanted by private collector. Items include itineraries, stage passes, posters, handbills, picture tickets, live recordings, magazines (Juke, Go set, Soundblast, Spunky). Groups of interest are AC/DC, Cold Chisel, Angels, Rose Tattoo, Midnight Oil, Jimmy Barnes. Contact Leigh 0419 001 856, write to 125 Evan Street PENRITH NSW 2750, email LHarrison@nepean.uws.edu.au

NEED CREW? Staging * Lighting * Sound

LIVE CREWING can provide you with experienced crew for your Concert Productions, Press Conferences, Launches, Corporate Seminars etc.

Office (02) 9792 7770 Fax (02) 9792 6660
Contact Fred Ward Mobile 0418 212 431

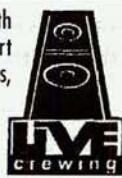

POSITIONS VACANT

TRAINEE TECHNICIAN

A position exists within the NSW branch of GUET for a Trainee Technician. Applicants should have a basic knowledge in cinema. Some experience preferable but not essential. An easy-going personality and a willingness to learn will see the right person in this job. Please forward resumes to Mal Barnes c/o address below.

SOUND/VIDEO/LIGHTING OR CINEMA TECHNICIANS

GUET seeks experienced Sound/Video/Lighting and/or Cinema technicians for full-time positions based in the Lane Cove office. If you have an even temperament, know the meaning of teamwork and thrive on a challenge, come over to the world of sound, video, lighting & cinema. Please forward all resumes to Mal Barnes c/o address below.

Greater Union Entertainment Technology
87 Mars Road, Lane Cove NSW 2066
email: mal_barnes@guet.com.au
fax: (02) 9420 3436 for further details
phone Mal Barnes on (02) 9420 4888



FOR SALE

2 DYNALITE 12 x 2.4KW Production Dimmers, front breakers, rear outlets, recently serviced Excellent condition. \$850.00 each. PH: +61 2 9311 1137

AAA After a certain piece of gear or have some to sell. Call Neil @ Cannon Sound on (02) 9948 4440.

AFTERMARKET quality replacement diaphragms. From \$36 (+ GST), to suit many popular 1", 1+1/2" and 2" drivers including: Altec, Acoustician, Coral, F.A.S., P.Audio, Zomax and around 20 different JBL models (ie. JBL 2416 [VR Series and EONs], 2440, 2441, 2445H, 2445J, 2446H, JBL LE85, 2470, 2421, 2421B, 2420, 2425H, 2426H, 2426J, 2412 [TR Series] etc) Next day delivery Australia-wide. See Spec Table at

www.cannonsound.com.au
or call (02) 9948 4440

AMPLIFIERS. Jands 920 500w + 500w. Delivered to your door Australia-wide \$550 each (+ GST). Value at around \$0.50 per watt. Getting down to the last! Cannon Sound (02) 9948 4440

AMPLIFIERS. AM1600 Amplifier \$1600 (+ GST) each. Carver PM1200 Amplifier 2RU and really

light (save your back) \$1200 (+ GST). Crest 7001 with crossover cards 980w/980watts @ 4 Ohms \$2500 (+ GST) each. Crest CA-9 \$1800 (+ GST). Only a 1 left in stock! Cannon Sound (02) 9948 4440.

AMPLIFIERS Yorkville Canadian made - new in the carton, 2 year unlimited/you break it - we fix it warranty. Audiopro

AP6040 - 2000 watts per side into 4 Ohms and AP4040 - 1200 watts per side into 4 Ohms. Extremely reasonably priced. Call Cannon Sound on (02) 9948 4440 for a pleasant surprise.

BOSE 802C Speakers. Large quantity available @ \$1300 a pair (+ GST). Controllers available also. Cannon Sound (02) 9948 4440.

Cobra Mk1 Speakers. Quantity available. \$2000 (+ GST) a pair. Cannon Sound (02) 9948 4440 or sales@cannonsound.com.au

COMPLETE Touring System for sale. PA's, lighting systems and truck. Will sell complete or will separate. Effects and Processors: Yamaha, Roland, ARX, DBX from \$300. Amps: Perreaux,

Jands, Phaseliner from \$500. Desks: Soundcraft, TAC from \$1000. Contact 0408 886 188 for info.

EV MS2000 VHF radio systems with handhelds. Quantity available @ \$300 (+ GST) per system. Visit www.cannonsound.com.au or phone (02) 9948 4440

EV PLASTIC boxes available now - most in quantities. EV SX200 Speakers \$1400 (+ GST) the pair. EV S00 Speakers \$1000 (+ GST) the pair. EV FM1202 Monitors \$1000 (+ GST) the pair. EV FM12C dual concentric monitor (1 only) \$500 (+ GST). Cannon Sound (02) 9948 4440.

FAIRLIGHT for Sale! MFX-2 with monitor, console, output loom, 2 x gig drives. Fully maintained, available now. Price \$22,000 Inquiries: John Rowland +61 3 9699 8399 Email: rowland@rowlands.com.au.

FOSTEX E16 Analogue tape machine with remote On Special Only \$1500 PH: +61 2 9555 1710

INTELLIGENT LIGHTING. 9 Robocolor Pro 400 fixtures in excellent condition, supplied with professional quality roadcases (2 x 4-way, 1 x 2-way), lamps, IEC cables and 10 metre data cables. Used and owned by Silverchair for 1999 touring. \$8000 the package. Contact Hugh on

0418 277 288 or lights@heff-t.com

FOSTEX RD8 Adat with remote + manual sync. Capable. \$2750 Call 0412 660 595 or union@labyrinth.net.au

Jands 12 channel Rock racks \$500 (+ GST) each. Cannon Sound (02) 9948 4440

JANDS EIGHT GATE \$275 (+ GST). Cannon Sound (02) 9948 4440. Call Cannon Sound (02) 9948 4440 for price or visit www.cannonsound.com.au

JBL2226 15" SPEAKERS \$450 (+ GST) each. Cannon Sound (02) 9948 4440. Call Cannon Sound (02) 9948 4440 for price or visit www.cannonsound.com.au

LEXICON PCM 70 \$1950 with manual TC Electronics 96K Finalizer in box with manuals \$3750 0412 660 595 or union@labyrinth.net.au

MIXERS. Mackie SR24-4 in very good condition with case \$2200 (+ GST). Tascam M-1016.8 mic + 4 stereo line chan-

Professional Audio and Lighting Sales, Service and Production

2 Bridge Street,
Rydalmere NSW 2116
Ph: +61 2 9638-0302
Fax: +61 2 9638-0331
hire@lotsofwatts.com.au
www.lotsofwatts.com.au

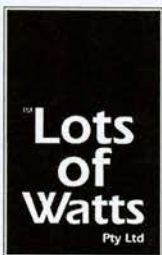

The gobo Factory

GLASS  STAINLESS STEEL

*Custom-made and Catalogue Range
Customised Message & Theme Sets*

Quality, Service and Competitive prices

Ph: 61 3 5439 3770 Fax: 61 3 5439 3601

Email: gobos@netcon.net.au

Website: www.gobo.com.au

Drapes and Stages

from **Staging Rentals**
"Your complete staging service"

**Big range Top quality On time
Friendly, professional advice**

Ph: (02) 9519 6300

Fax: (02) 9519 6489

1 Pyrmont Bridge Road
Camperdown NSW 2050
mail@stagingrentals.com.au
www.stagingrentals.com.au



THE AUDIO DEPT.

Wireless Microphone Specialists. 20 years experience. Large inventory of Sony UHF systems, Shure UHF and VHF systems, and now **Garwood In-Ear** monitors. Short or long term hire for all applications, sales and full service. Authorised Sony Wireless Service Centre.

**Call for a quote.
(03) 9415 1868.**



SOUND & LIGHTING
Hire, Design, Sales
Installations, Service

47 Auburn Street, Wollongong
Ph: (02) 4229 6010

GOBO

Greyscale Glass, Colour & Steel

Lighting by Design
First with the glass technology to OZ
now standard in Martin 918 and Mac500.
Original designs & innovative ideas.

Tel: 0755 377 002 Sales@LBD.com.au
Fax: 0755 292 226 www.LBD.com.au

**Graftons
Lighting & Sound**

Professional Equipment & Service
**Hire, Sales, Installs
Production & Design**

6/890 Bourke St, Waterloo NSW 2017
Tel: (02) 9698 7777 Fax: (02) 9698 9999
Lighting: graftons@idx.com.au
Sound: info@productionsservices.com.au
Sound: www.productionsservices.com.au

nels, 4 auxiliaries \$590 (+ GST). Cannon Sound (02) 9948 4440 or sales@cannonsound.com.au

for a catalogue and price list

ROCKARD Coatings for your PA and roadcases - the true industry standard. Available in 1,2,4 & 18 litres. Black as well as custom colours including various greys, reds and blues etc. We also can match colours from any colour chart or sample. Call Cannon Sound (02) 9948 4440.

SELLOUT-BAND PA Great prices, AM AMPS, Yamaha Graphics, JBL's, Multicores. Ring +61 2 6625 2511

SPEAKERSTANDS. Heavy duty - take up to 50 Kg. Brand new \$90 (+

GST) each. Cannon Sound (02) 9948 4440.

SOUNDCRAFT 600 Series 24/8/2 with 16 tape returns. \$2500 (+ GST). must sell at this price..... Cannon Sound (02) 9948 4440

SUB. BRAND NEW dual chamber loaded with single 800 watt R.M.S. 18" driver. 132 dB maximum SPL, 46 KG, compact, black carpet finish etc. RRP \$1800 incl. GST. Trade and wholesale enquiries welcome. Call Cannon Sound (02) 9948 4440 or visit www.cannonsound.com.au for the full Cannon Cabinet range

VALVE HAMMOND and 122 Leslie 1932 A

Model. Looks like B3/C3 Excellent order \$950C PH: 0411 886 066

VEGA R-22 Receivers with beltpacks and handhelds with a Vega Diversity Multicoupler (Ariel system). Set of 4. Frequencies are 174-250, 177-325, 180-075 & 178-600. \$1600 (+ GST) the lot. Cannon Sound (02) 9948 4440.

VEGA R-622 UHF Wireless Systems. Receivers with beltpacks. 4 systems in stock at \$900 each (+ GST). Frequencies available 651-525, 626-450, 588-025 & 617-975. Cannon Sound (02) 9948 4440.

YAMAHA EMX220C, roadcased \$1600, 3 x

Beta 58 Mics \$200ea, AM1600 amp \$1500, 4 x AM F300 wedges \$800ea, ph +61 3 9416 3636 or 0418 543 048

YAMAHA SPX900 \$700 (+ GST). Cannon Sound (02) 9948 4440.

STUDIO HIRE

WOODSTOCK STUDIOS World class 24 Track Studio. Excellent rates. Specials for time booked

this Winter. PH: +61 3 9631 9011 or 0417 133 217

WANTED

GRAPHIC EQ Sansui Se-7 Only. Any Condition. Contact Greg Williams +61 3 9372 2266

ROADCASES for PROFESSIONALS

de Sine
ROADCASES

STANDARD RANGE & CUSTOM MANUFACTURE LIMITED LIFETIME WARRANTY APPLIES TO ALL CASES

CALL US FOR A CATALOGUE & PRICE LIST

PH: 07 3899 2971 FAX: 07 3899 0155
Email: desine@powerup.com.au

B.S. Sound PA Hire

3k PA with separate F/B, LX & crew, Driveway Vocal PA Systems & LX, Mics & components also available.

Contact Mark Barry for free quote
(03) 9531 1403 or 041 999 3966

www.bsound.com.au
mark@bsound.com.au

HUM ELIMINATOR™
MADE IN THE USA BY EBTECH



Hum Eliminator™
Silence AC Hum, forever!
We've all heard it. That buzz, that noise, that AC hum pouring through audio equipment. The Hum Eliminator breaks the groundloops safely, while leaving all signal grounds intact. No dangerous ground lifting. Works with balanced or unbalanced signal at either end.
Just plug it into the signal lines between offending pieces of equipment and you're done! No hum. No signal degradation. No filtering. No noise gates. No dangerous ground lifts. No signal ground lifts.

HE-2 2 Channel MiniBox \$199
HE-8 8 Channel 1-Rack Unit \$599

Line Level Shifter™
Solve -10dBV to +4dBu problems
What do you do when you need to connect a low volume, -10dBV output (cassette deck, CD player, synth), into a high volume +4dBu input (DAT Machine, multitrack recorder)? The Line Level Shifters allow you to use equipment with different line level requirements. It converts between -10dBV and +4dBu equipment.
Using the physics of inductance and impedance matching, there's no added noise. The units also contain Ebtech's Hum Eliminator to eliminate AC hum.

LL-2 2 Channel MiniBox \$249
LL-8 8 Channel 1-Rack Unit \$699

Need more info? Contact...
AUSTRALIAN AUDIO SUPPLIES
TELEPHONE (02) 4388 4666

Australian Audio
SUPPLIES

Sydney Digital Productions & OB Services

Offers competitive hire rates for the following equipment

- Sony Digital Betacam VTR's (DWW A500P)
- Time code Generator's
- Sync Pulse Generator's
- ADA's & VDA's (SDI)

Delivery/pickup available
Ph: 0402 071 434 Fax: (02) 9619 2061
www.sydneydigitalproductions.com.au

ACOUSTICS

- Manufacturers of high performance modular acoustic panels
- Room design
- Acoustic analysis



ARO TECHNOLOGY
PH: (08) 8346 4199

IN THE DARK?

SEEK THE LIGHT!

Read John 8:12 ... and then dial up www.electricsunshine.com.au

Technicality

Specialists in
AUDIO VISUAL SERVICE & REPAIR

- Video/Data Projectors
- P.A. Systems
- Video Cameras
- Broadcast Equipment
- Digital Audio & Video
- Studio Equipment
- Home Theatre
- Stage Equipment

Ph: (03) 9737 0007
technicality@service.mel.net

HirePoint360 MAJOR NEW Version

For A/V, Lighting & Audio Equipment rental & production, staging & business theatre.

- Australia's No.1 - Save your valuable time, look at the best software with local service first.
- Download a demo now! www.HireP.com

RentalPoint Software (formerly HirePoint Software) Contact: Stephen Collard, SF Business Dev.
Ph (03) 9761 2727 Mob 0407 541 290

RentalPoint2000 Hire Software

FOR
**CUSTOM CASES
SPEAKER ENCLOSURES**

TUFFA
CASES & CABINETS PTY LTD

Ph (02) 9153 9373 Fax (02) 9153 9329
Unit 5, 15 Lorraine Street Peakhurst 2210

Connections Advertiser & Brand

EASYFINDER!

Please.... tell them you saw it in Connections!

Company Name	Phone	Website address	Brand	Page Number
Altronic Distributors	+61 8 9328 2199	www.altronic.com.au	Redback, Altronic Catalogue	54
Amber Technology	+61 2 9975 1211	www.ambertech.com.au	Neutrik	14
Amber Technology	+61 2 9975 1211	www.ambertech.com.au	Canare	30
AON Risk Services	+61 2 9253 7000	www.aonrisk.com.au	Entertainment Insurances	58
ARX	+61 3 9555 7859	www.arx.com.au	ARX	46
Audio Telex Communications	+61 2 9647 1411	www.audiotelex.com.au	Australian Monitor	27
Audio Telex Communications	+61 2 9647 1411	www.audiotelex.com.au	Symetrix, Sabine	53
Australian Audio Supplies	+61 2 4388 4666	www.ausaudio.com.au	Mackie	21
Birkart Concert Cargo	+61 3 9696 2988	www.birkart.com	Transport & Logistics	23
Browns Precision Welding	+61 3 9455 2899	not available at this time	Browns Truss	34
Bytecraft	+61 3 9587 2555	www.bytecraft.com.au	Robert Juliat	57
CMI - Central Musical Instruments	+61 3 9315 2244	www.cmi.com.au	dB Technologies	45
Connections Shop	1800 635 514	www.conpub.com.au	Merchandise	40,41
Corporate Audio Services	+61 3 9474 1066	www.corporateaudio.com.au	Turbosound	20
EAW	+61 3 9415 1585	www.eaw.com	EAW	31
Emtec Magnetics	1800 805 691	www.emtec-magnetics.com	BASF Tracking Guide	Starts 73
EVI	+61 2 9648 3455	www.eviaudio.com.au	EV	35
Group Technologies	+61 3 9872 5000	www.gt-aust.com	RCF	33
GUET	+61 2 9420 4888	www.guet.com.au	Celestion	44
GUET	+61 2 9420 4888	www.guet.com.au	Studiomaster	46
H&C Audio	+61 3 9876 2333	www.ozemail.com.au/~hcaudio	Omnimount Systems	61
Hoisting Equipment Specialists	+61 2 9584 1177	not available at this time	OzBlok	49
Infocomm	+65 297 2822	not available at this time	Infocomm Asia	51
Interlink System Solutions	+61 2 9638 0777	www.dbsound.com.au	Interlink	58
Jands	+61 2 9582 0909	www.jands.com.au	Shure	2
Jands	+61 2 9582 0909	www.jands.com.au	JBL	4
Jands	+61 2 9582 0909	www.jands.com.au	Soundcraft	39
Lots of Watts	+61 2 9638 0302	www.lotsofwatts.citysearch.com.au	Sale	24
Martin Professional	+61 2 9898 1111	www.showtech.com.au	Martin	19
Meteorlites	+61 8 9227 5590	www.iinet.au/~mudlark3	Meteorlites	37
Meyer Sound Australia	1800 4 MEYER	www.meyersound.com.au	Meyer	6,7
Micro MM Laser	+61 2 8850 3945	www.micrommlaser.com	Micro MM Laser	60
Navigator Systems	+44 7000 628 797	www.navigator.co.uk	Hiretrack	64
NSCA - National Systems Corp Australia	+61 3 9434 1888	www.chaiyo.com.tw	Chiayo	47
Fenn Fabrication	+61 3 9335 6455	www.penn-fabrication.com.au	MSB	65
Philips	1800 132 022	www.teamphilips.com.au	Philips	83
Pioneer	1300 364 765	www.pioneeraus.com.au	Pioneer	11
Production Audio Services	+61 3 9415 1585	www.productionaudio.com.au	Crest	17
Production Services (UK)	rocky@proservs.freemove.co.uk		Laboratory Series Technology	62
Public Event Group	+61 2 8585 5200	www.publicevent.com.au	Stageline	25
S&E	+61 2 9211 3711	www.sae.edu	School of Audio Engineering	13
Save Time Visuals	+61 3 9888 2111	www.savetimevisuals.com.au	AV, M' media, Presentation Specialists	16
Selecon	+61 2 9319 3133	www.seleconlight.com	Selecon	63
SGM	1800 648 111	www.sgm.it	SGM	15
Show Lighting Australia	+61 2 9898 1111	www.showtech.com.au	Clay Paky	Back Cover
Sony	+61 2 9887 6666	www.sony.com.au	Sony	28
Specialised Lamp Supplies	1300 302 852	not available at this time	Specialised Lamps	55
Stage & Screen	+61 2 9383 4544	www.stageandscreen.com	Travel & Transport	10
TAG - Technical Audio Group	+61 2 9810 5300	www.tag.au.com	TAG Catalogue	Centre Insert
The Resource Corporation	+61 3 9877 8233	www.trc.com.au	K&M	54
The Resource Corporation	+61 3 9877 8233	www.trc.com.au	SC Systems	61
The Resource Corporation	+61 3 9877 8233	www.trc.com.au	Eurocable	69
The Unique Flamelight Company	+61 8 9228 3000	www.uniqueflamelight.com	Unique Flamelight	50
Trader	1800 635 514	www.conpub.com.au	Trader	Starts 79
Yamaha	+61 3 9693 5111	www.yamaha.co.jp/product/	Yamaha	29,59

Subscribe to Connections! Save and get your magazine faster!

Call 1-800-635-514 or online at www.conpub.com.au

click on

to professional audio

PHILIPS

Welcome to **PHILIPS**
Communication, Security & Imaging

NO RISK
30 DAY MONEY BACK OFFER

Philips invites you to *grow your business* as a Team Philips Member. Join Philips Communication, Security & Imaging (CSI) to gain access to the latest in high technology Closed Circuit TV (CCTV) and Public Address (PA) products.

Now it is even easier to connect and transact with a brand that you can trust. Philips is a world class electronics company with a strong presence and team of experts in CCTV & PA in Australia. Register today!

www.teamphilips.com.au

- Online ordering of high quality professional CCTV and Audio products by account or credit card
- 2 year warranty for all products ordered online
- Free telephone and online technical support
- 30 day money back offer** NO RISK
- FREE delivery** for orders over \$2000
- Stay informed with our latest products and promotions
- Online access to technical documentation

**See terms and conditions on the website

REGISTER ONLINE

April 3, 2000 is the official launch date for Philips Communication, Security & Imaging's exciting new E-Commerce web-site. Registered Team Philips Members will gain access to the latest in high technology Closed Circuit TV (CCTV) and Public Address (PA) products. Now it is even easier to connect and transact with a brand that you can trust. Freecall 1800 132 022 or visit us at www.teamphilips.com.au



PHILIPS

Let's make things better.

The winner is... Stage Line



STAGE LINE
1999 LIVE! AWARDS
New Lighting Fixture
of the Year



STAGE LINE
1999 ETA AWARDS
Club Lighting Effect

STAGE COLOR 300
1999 ETA AWARDS
Budget Lighting Effect



STAGE LINE
1998 MOLSON BEDA AWARDS
The New Product of The Year



STAGE LINE
1998 EDDY AWARD
The Art and Technology of
Show Business



STAGE LINE
1998 ETA AWARDS
Innovative Lighting Product

Distributor:

SHOW LIGHTING AUSTRALIA Pty Ltd

Adm. Office: 13-15 Bridge Street - Rydalmere NSW 2116 - PO Box 480 Rydalmere NSW 170
Tel. +61 (0) 298981666 - Fax +61 (0) 298981222 - E-mail: showtech@showtech.com.au

CLAY PAKY S.p.A.

Via Pascoli, 1 - 24066 Pedrengo (BG) Italy

Tel. +39-035-654311 - Fax +39-035-665376

Internet: www.claypaky.it



PROFESSIONAL SHOW LIGHTING